



**BAHAMAS  
BUREAU OF  
STANDARDS  
AND QUALITY**

*QUALITY IS OUR STANDARD*

**FINAL DRAFT BAHAMAS NATIONAL STANDARD**

**Building construction -- Accessibility and usability of the built environment**

**FDBNS ISO 21542:2011(E)**

Bahamas Bureau of Standards & Quality (BBSQ)  
Source River Centre, 1000 Bacardi Road  
P.O. Box N- 4843, Nassau, New Providence, Bahamas  
Tel: (242) 362-1748 thru 55  
Fax: (242) 362-9172  
Email: [standards@bbsq.bs](mailto:standards@bbsq.bs)  
Website: [www.bbsq.bs](http://www.bbsq.bs)



© BBSQ – All rights reserved. No part of this publication is to be reproduced without the prior written consent of BBSQ

**NOTICE**

Standards are subjected to periodic review.

The next amendment will be sent without charge if you return the self-addressed label. If we do not receive this label we have no record that you wish to be kept up-to-date. Please note amendments are not exclusive of a revision of the document.

Our address:

**Bahamas Bureau of Standards & Quality (BBSQ)**

Source River Centre  
1000 Bacardi Road  
P.O. Box N- 4843  
Nassau, New Providence  
Bahamas

----- (  cut along the perforated line  ) -----

BNSXX:20XX

NAME: \_\_\_\_\_

\_\_\_\_\_

COMPANY/DESIGNATION: \_\_\_\_\_

\_\_\_\_\_

FDBNS FOR PUBLIC COMMENTS ONLY APRIL - JUNE 2019

**BBSQ Foreword**

"This national standard is identical to the English version of International Standard ISO 21542:2011, **Quality management — Customer satisfaction — Guidelines for monitoring and measuring Building construction -- Accessibility and usability of the built environment**. The national committee responsible for this standard is Technical Committee 9 Management Systems. This standard contains requirements that are relevant for The Bahamas.

FDBNS FOR PUBLIC COMMENTS ONLY APRIL - JUNE 2019



FDBNS FOR PUBLIC COMMENTS ONLY APRIL - JUNE 2019

# Contents

Page

Foreword.....	viii
Introduction.....	ix
1 Scope .....	1
2 Normative references .....	1
3 Terms and definitions .....	2
4 General design considerations .....	9
4.1 General.....	9
4.2 Design requirements according to human abilities .....	9
4.3 Key accessibility issues.....	9
5 Approach to the building .....	12
5.1 Arrival by motor vehicle.....	12
5.2 Principal entrance.....	12
6 Designated accessible parking space.....	13
6.1 Location.....	13
6.2 Number of designated accessible parking spaces .....	13
6.3 Car parking .....	13
6.4 Van parking with auxiliary movable ramps .....	14
6.5 Signage.....	15
6.6 Surface.....	15
6.7 Kerb ramp from parking space to an adjacent higher pedestrian path .....	15
6.8 Indoor parking.....	16
6.9 Parking control.....	16
7 Paths to the building .....	16
7.1 General.....	16
7.2 Wayfinding, guided path and other physical support of information .....	17
7.3 Path .....	18
7.4 Width of the path.....	19
7.5 Passing space for wheelchair users.....	19
7.6 Turning space for wheelchair users on landings.....	20
7.7 Path construction .....	20
7.8 Stepped path and stair .....	20
7.9 Width of stepped path and stair.....	21
7.10 Landing of stepped path and stair.....	21
7.11 Landings of sloped paths .....	21
7.12 Support and guidance by a handrail on paths .....	21
7.13 Drainage of access routes .....	21
7.14 Solitary obstacles in a path .....	21
7.15 Guards against falling within a path.....	22
8 Ramps.....	22
8.1 General.....	22
8.2 Slope and length.....	24
8.3 Width of ramps.....	25
8.4 Landings of ramps.....	25
8.5 Support and guidance by handrail on ramps .....	25
8.6 Drainage of ramp .....	25
8.7 Surface materials.....	25
9 Guarding along paths and ramps .....	25

10	Building entrances and final fire exits .....	26
10.1	General .....	26
10.2	Identification .....	27
10.3	Floor level at the entrance .....	27
10.4	Principal entrance doorway .....	27
10.5	Doorway width .....	27
10.6	Clear height of a doorway .....	28
10.7	Circulation space .....	28
10.8	Lobbies .....	28
10.9	Visibility through an entrance door .....	29
11	Horizontal circulation .....	29
11.1	General .....	29
11.2	Internal passages .....	30
11.3	Turning space for 90° turn of a wheelchair in corridors .....	31
11.4	Circulation space for 180° wheelchair turn .....	31
12	Vertical circulation .....	32
12.1	General .....	32
12.2	Ramps in buildings .....	32
13	Stairs .....	32
13.1	Rise and going of steps .....	32
13.2	Minimum width of stair flights .....	33
13.3	Staircase landings .....	34
13.4	Head clearance .....	34
13.5	Visual and tactile warnings .....	35
13.6	Guards along stairs .....	35
14	Handrails .....	36
14.1	General .....	36
14.2	Provision of handrails .....	36
14.3	Profile of a handrail .....	37
14.4	Continuity of a handrail .....	37
14.5	Height of a handrail .....	37
14.6	Horizontal extension of a handrail .....	38
14.7	Visual and tactile information .....	38
14.8	Mechanical resistance .....	38
15	Lifts (Elevators) .....	38
15.1	General comments .....	38
15.2	Inner dimensions of cars .....	39
15.3	Lift car entrance — Door opening .....	40
15.4	Equipment in the car .....	41
15.5	Control devices and signals .....	43
15.6	Use of lifts (elevators) for fire evacuation .....	45
16	Vertical and inclined lifting platforms .....	46
16.1	General application .....	46
16.2	Platform dimensions .....	46
16.3	Vertical lifting platforms .....	46
17	Escalators and moving walks .....	46
18	Doors and windows .....	47
18.1	Doors and door furniture .....	47
18.2	Fire resisting doorsets .....	53
18.3	Windows and window hardware .....	54
19	Reception areas, counters, desks and ticket offices .....	55
19.1	Hearing and lip-reading .....	55
19.2	Location .....	55
19.3	Space to manoeuvre .....	55
19.4	Height .....	55

19.5	Lighting.....	56
19.6	Ticket systems .....	56
20	Cloakroom .....	56
21	Auditoriums, concert halls, sports arenas and similar seating.....	57
21.1	Hearing enhancement systems.....	57
21.2	Lighting for sign language interpretation .....	57
21.3	Designated seating areas for wheelchair users .....	57
21.4	Access to stage and backstage .....	57
21.5	Row and seat numbers .....	57
21.6	Accessible changing rooms .....	57
22	Conference rooms and meeting rooms.....	58
23	Viewing spaces in assembly areas .....	58
23.1	Floor area.....	58
23.2	Sight lines.....	59
24	Bars, pubs, restaurants, etc. ....	59
25	Terraces, verandas and balconies .....	59
26	Toilet rooms and sanitary rooms .....	60
26.1	General.....	60
26.2	WC compartments for ambulant disabled people.....	60
26.3	Wheelchair user accessible toilet rooms .....	61
26.4	Dimensions for wheelchair user accessible toilet rooms .....	61
26.5	Toilet room doors .....	66
26.6	Toilet seat .....	66
26.7	Grab rails .....	67
26.8	Toilet paper.....	68
26.9	Washbasin.....	69
26.10	Water supply .....	70
26.11	Taps.....	71
26.12	Urinals.....	71
26.13	Other fittings .....	71
26.14	Alarm .....	71
26.15	Emergency warning alarm .....	72
26.16	Shower.....	72
26.17	Individual shower room .....	73
26.18	Bathrooms .....	74
27	Accessible bedrooms in non-domestic buildings.....	77
28	Kitchen areas .....	79
29	Storage areas .....	79
30	Facilities for guide dogs and other assistance dogs.....	79
30.1	General.....	79
30.2	Relief facilities for guide dogs and assistance dogs.....	79
31	Floor and wall surfaces.....	80
32	Acoustic environment.....	80
32.1	General.....	80
32.2	Acoustic requirements.....	80
32.3	Hearing enhancement systems.....	81
33	Lighting.....	82
33.1	General.....	82
33.2	External lighting.....	82
33.3	Natural lighting.....	82
33.4	Artificial lighting.....	82
33.5	Lighting to facilitate wayfinding.....	82
33.6	Controllable and adjustable lighting.....	83
33.7	Light levels in different areas .....	83

33.8	Lighting in auditoriums .....	83
33.9	Glare and shadows .....	83
34	Fire emergency warning systems, signals and information .....	84
34.1	General .....	84
34.2	Light warning signals .....	84
34.3	Acoustic warning systems .....	84
35	Visual contrast .....	84
35.1	General .....	84
35.2	Choice of colours and patterns .....	85
36	Equipment, controls and switches .....	86
36.1	General .....	86
36.2	Location, heights and distances .....	86
36.3	Location of controls from walls, corners and opening doors .....	88
36.4	Operation .....	89
36.5	Identification .....	90
36.6	Usability .....	90
36.7	Telephones .....	90
36.8	Card access, dispensing machines and automatic teller machines (ATMs), etc. ....	91
36.9	Security access systems .....	93
36.10	Drinking fountains .....	93
36.11	Refuse bins .....	93
37	Furnishing .....	93
37.1	General .....	93
37.2	Seating in waiting areas .....	93
37.3	Seating at desks, tables, etc. ....	94
38	Fire safety, protection and evacuation for all .....	95
38.1	Fire engineering design objectives .....	95
38.2	Principles of fire evacuation for all .....	95
38.3	Assisted fire evacuation .....	96
38.4	Evacuation chairs .....	97
38.5	Emerging fire evacuation technologies .....	97
38.6	Fire defence plans .....	97
39	Orientation and information .....	98
39.1	General .....	98
39.2	Principle of two senses .....	99
39.3	Audible information .....	99
39.4	Levels of information .....	99
40	Signage .....	99
40.1	General .....	99
40.2	Main types of signs .....	100
40.3	Placement of signs .....	100
40.4	Height and location of signs .....	101
40.5	Font and size of lettering .....	102
40.6	Differences in LRVs .....	102
40.7	Glare free .....	103
40.8	Illumination .....	103
40.9	Understandable .....	103
40.10	Provision of raised tactile and Braille signs .....	103
40.11	Tactile letters, figures, signs and graphical symbols .....	103
40.12	Braille .....	104
40.13	Tactile symbols .....	104
40.14	Tactile maps and floor plans .....	104
40.15	Information displays .....	105
41	Graphical symbols .....	105
42	Management and maintenance issues .....	109



<b>Annex A (informative) Tactile walking surface indicators (TWSIs)</b> .....	<b>110</b>
<b>Annex B (informative) Human abilities and associated design considerations</b> .....	<b>118</b>
<b>Annex C (informative) Circulation spaces at doorways</b> .....	<b>132</b>
<b>Annex D (informative) Fire safety and assisted evacuation for all in buildings</b> .....	<b>144</b>
<b>Annex E (informative) Management and maintenance issues</b> .....	<b>146</b>
<b>Bibliography</b> .....	<b>149</b>

FDBNS FOR PUBLIC COMMENTS ONLY APRIL - JUNE 2019

## Foreword

ISO (the International Organization for Standardization) is a worldwide federation of national standards bodies (ISO member bodies). The work of preparing International Standards is normally carried out through ISO technical committees. Each member body interested in a subject for which a technical committee has been established has the right to be represented on that committee. International organizations, governmental and non-governmental, in liaison with ISO, also take part in the work. ISO collaborates closely with the International Electrotechnical Commission (IEC) on all matters of electrotechnical standardization.

International Standards are drafted in accordance with the rules given in the ISO/IEC Directives, Part 2.

The main task of technical committees is to prepare International Standards. Draft International Standards adopted by the technical committees are circulated to the member bodies for voting. Publication as an International Standard requires approval by at least 75 % of the member bodies casting a vote.

Attention is drawn to the possibility that some of the elements of this document may be the subject of patent rights. ISO shall not be held responsible for identifying any or all such patent rights.

ISO 21542 was prepared by Technical Committee ISO/TC 59, *Buildings and civil engineering works*, Subcommittee SC 16, *Accessibility and usability of the built environment*.

This first edition cancels and replaces ISO/TR 9527:1994.

## Introduction

This International Standard provides building users, architects, designers, engineers, builders, building owners and managers, manufacturers, policy makers and legislators with requirements and recommendations to create a sustainable built environment which is accessible.

The purpose of this International Standard is to define how the built environment should be designed, constructed and managed to enable people to approach, enter, use, egress from and evacuate a building independently, in an equitable and dignified manner and to the greatest extent possible.

The intention of this International Standard is to meet the needs of the majority of people. This goal is achieved by agreement on minimum standards of provision which are generally accepted to accommodate the diversities of age and of human condition. This agreement has been reached by consensus between different countries all over the world.

In some countries a higher level of technical specifications has been achieved due to their long history in developing accessible building standards and regulations. The requirements of this International Standard are not intended to replace more demanding requirements defined in those national standards or national regulations.

These principles are supported by Preamble (g) and Articles 9, 10 and 11 of the United Nations Convention on the Rights of Persons with Disabilities.

NOTE 1 The Convention on the Rights of Persons with Disabilities, with its Optional Protocol, was adopted by the General Assembly of the United Nations on 13 December 2006. It came into force, i.e. became an international legal instrument, on 3 May 2008. Furthermore, information about the Convention and its text can be found on the United Nations website: <http://www.un.org/disabilities/>. The Convention is serviced by a joint secretariat, consisting of staff from both the United Nations Department of Economic and Social Affairs (DESA), based in New York, and the Office of the High Commissioner for Human Rights (OHCHR) in Geneva.

This International Standard sets out the objectives, design considerations, requirements and recommendations that ISO expects to result in accessible and usable buildings when fully implemented.

This International Standard should be applied to new and existing buildings.

If these design requirements are taken into consideration in the early stages of building design, the costs of providing accessibility and usability measures are minimal and raise the value of the property in terms of sustainability. Where alterations and refurbishment occur, the additional cost depends on the size and complexity of the particular building and its adaptations.

NOTE 2 For further information on costs of accessible buildings see ETH-Study from Switzerland: [http://www.hindernisfrei-bauen.ch/kosten\\_f.php](http://www.hindernisfrei-bauen.ch/kosten_f.php).

This International Standard contains a combination of essential requirements, i.e. provisions which are essential for accessibility and usability of the built environment, and recommendations for an improved environment. The essential requirements are preceded by the word "shall". For recommendations which are desirable, the provisions are preceded by the word "should".

This International Standard may be applied in accordance with the National Regulations of the Member Bodies who have adopted this International Standard and stated in their National Foreword the terms under which it is to be applied.

This International Standard may be used by

- a) national authorities to determine a specific programme of implementation, and
- b) building owners to fulfil their responsibilities according to anti-discrimination and equity legislation, or on a voluntary basis.

As most buildings are subject to refurbishment, upgrade or change of use at some stage during their life cycle, national regulations can require all or part of this International Standard to be applied.

National building regulations may include considerations of legislation on equality, particular building and site constraints, different types of buildings, and the costs and benefits to society generally. It is also important to ensure that existing buildings of historical, architectural and cultural importance are accessible. In such cases it might be necessary for national authorities to allow some exceptions to this International Standard, as well as recommending appropriate alternative accessibility measures.

This International Standard should lead to continuous improvement in the built environment. Whilst the objectives always remain unchanged, the means of achieving them is part of a continuing process of change, i.e. as human knowledge and building technology improve and as the relationship between generally accepted building practice and technology alters.

ISO/IEC Guide 71 and its guidance document ISO/TR 22411 should be used to augment and assist in understanding the requirements of this International Standard.

Within the figures all dimensions are given in millimetres and measured from finished surfaces, unless otherwise stated. All figures are provided as examples.

FDBNS FOR PUBLIC COMMENTS ONLY APRIL - JUNE 2019

# Building construction — Accessibility and usability of the built environment

## 1 Scope

This International Standard specifies a range of requirements and recommendations for many of the elements of construction, assemblies, components and fittings which comprise the built environment. These requirements relate to the constructional aspects of access to buildings, to circulation within buildings, to egress from buildings in the normal course of events and evacuation in the event of an emergency. An informative annex is also included which deals with aspects of accessibility management in buildings.

This International Standard contains provisions with respect to features in the external environment directly concerned with access to a building or group of buildings from the edge of the relevant site boundary or between such groups of buildings within a common site. This International Standard does not deal with those elements of the external environment, such as public open spaces, whose function is self-contained and unrelated to the use of one specific building, nor does it deal with single family dwellings, other than those circulation spaces and fittings that are common to two or more such dwellings.

At present, consideration is being given to the development and publication of additional parts to this International Standard to deal with the types of external environments described above and single family dwellings.

For existing buildings there are options included in some paragraphs which appear as "*exceptional considerations for existing buildings in developing countries*" (see "Guidance on the Implications of the ISO Global Relevance Policy for CEN Standardization", 2005) and as "*exceptional considerations for existing buildings*" where a lesser standard than expected in new developments is accepted on the grounds of technical and economic circumstances only.

The dimensions stated in this International Standard, relevant to the use of wheelchairs, are related to the footprint of commonly used wheelchair sizes and users. The footprint for a wheelchair within this International Standard is based on ISO 7176-5 and ISO/TR 13570-2<sup>1)</sup> and is 800 mm wide and 1 300 mm long. For larger wheelchairs and scooters, dimensions will have to be considered accordingly.

NOTE This International Standard is primarily written for adults with disabilities but it includes some specifications regarding the specific accessibility requirements that would suit children with disabilities. However, it is envisaged that more detailed requirements will be included in future revisions of this International Standard.

## 2 Normative references

The following referenced documents are indispensable for the application of this document. For dated references, only the edition cited applies. For undated references, the latest edition of the referenced document (including any amendments) applies.

ISO 4190-1:2010, *Lift (Elevator) installation — Part 1: Class I, II, III and VI lifts*

ISO 4190-5:2006, *Lift (Elevator) installation — Part 5: Control devices, signals and additional fittings*

1) Under preparation.

ISO 7176-5, *Wheelchairs — Part 5: Determination of dimensions, mass and manoeuvring space*

ISO 9386-1, *Power-operated lifting platforms for persons with impaired mobility — Rules for safety, dimensions and functional operation — Part 1: Vertical lifting platforms*

ISO 9386-2, *Power-operated lifting platforms for persons with impaired mobility — Rules for safety, dimensions and functional operation — Part 2: Powered stairlifts for seated, standing and wheelchair users moving in an inclined plane*

ISO/TR 13570-2<sup>1)</sup>, *Wheelchairs — Part 2: Typical values and recommended limits or dimensions, mass and manoeuvring space as determined in ISO 7176-5*

ISO/IEC Guide 71, *Guidelines for standards developers to address the needs of older persons and persons with disabilities*

International Commission on Illumination, CIE, Publication 15:2004, 3<sup>rd</sup> Edition, *Colorimetry*

### 3 Terms and definitions

For the purposes of this document, the terms and definitions given in ISO/IEC Guide 71 and the following apply.

#### 3.1 ability faculty

identifiable human attribute, including but not exclusively, to walk, to speak, to hear, to see, to feel by touch, to taste, to understand, and recognize

#### 3.2 accessibility

(buildings or parts of buildings) provision of buildings or parts of buildings for people, regardless of disability, age or gender, to be able to gain access to them, into them, to use them and exit from them

NOTE Accessibility includes ease of independent approach, entry, evacuation and/or use of a building and its services and facilities, by all of the building's potential users with an assurance of individual health, safety and welfare during the course of those activities.

#### 3.3 area of rescue assistance

building space directly adjoining, and visible from, a main vertical evacuation route, robustly and reliably protected from heat, smoke and flame during and after a fire, where people can temporarily wait with confidence for further information, instructions, and/or rescue assistance, without obstructing or interfering with the evacuation travel of other building users

NOTE "Robust" means structurally hardened and resistant to mechanical damage during the fire and for a period of time afterwards, i.e. the cooling phase.

#### 3.4 assisted evacuation

strategy that exists during which a designated person or persons provide assistance, during an emergency, to another person to leave a building or a specific part of the built environment and to reach a final place of safety

---

1) Under preparation.

### 3.5

#### **assistive product**

product especially produced or generally available, for preventing, compensating for, monitoring, relieving or neutralizing impairments, activity limitations and participation restrictions

EXAMPLE      Devices, equipment, instruments, technology and software.

[ISO 9999:2007, definition 3.3]

### 3.6

#### **attention pattern**

tactile walking surface indicators (TWSIs) that call attention to particular decision points

### 3.7

#### **audio description**

verbal narration that conveys the visual aspects of a presentation or performance

### 3.8

#### **building related ill-health**

adverse impact on the health of building users while living, working, generally occupying or visiting a specific building caused by the planning, design, construction, management, operation or maintenance of that building

### 3.9

#### **buffer zone**

compartments and/or spaces immediately adjoining the fire compartment in a building

### 3.10

#### **built environment**

external and internal environments and any element, component or fitting that is commissioned, designed, constructed and managed for use by people

NOTE      Loose items are excluded because decisions with respect to their location within the built environment are more likely to be under the day-to-day control of facilities managers and not of those who commission, design or construct the built environment.

### 3.11

#### **circulation space**

unobstructed space necessary for access to, into and within and egress from any part of the built environment

### 3.12

#### **colour deficiency**

inability to perceive certain colours and to clearly distinguish between combinations of these colours

### 3.13

#### **common**

serving more than one single-family dwelling or more than one building or more than one tenancy

### 3.14

#### **contraflow**

(fire) emergency access by fire fighters or rescue teams into a building and towards a fire, while people are still moving away from the fire and evacuating the building

### 3.15

#### **disorientation**

permanent or temporary inability of a person to orient himself or herself with regard to space, time and context in either the built environment or virtual environment

NOTE      Acute disorientation brought on by the use of alcohol, "social" drugs and some medicines, or dramatic alterations in a person's circumstances, e.g. involvement in a fire incident, is not uncommon or abnormal. Long term progressive disorientation is a symptom of a variety of psychological and/or neurological disorders.

### 3.16

#### **doorset**

building component consisting of a fixed part (the door frame), one or more movable parts (the door leaves), and their hardware, the function of which is to allow, or to prevent, access and egress

NOTE A doorset can also include a door sill or threshold.

### 3.17

#### **evacuation from a building on fire**

to withdraw, or cause to withdraw, all users from a fire building in planned and orderly phased movements to a place of safety remote from the building

### 3.18

#### **evacuation lift**

lift that can be used, during an emergency, for self or assisted egress

### 3.19

#### **fire compartment**

enclosed space, which may be subdivided, separated from adjoining spaces by fire barriers

[ISO 13943:2008, definition 4.102]

### 3.20

#### **fire compartmentation**

division of a building into fire-tight compartments, by fire and smoke resisting elements of construction, in order to:

- contain an outbreak of fire;
- prevent damage, within the building, to other adjoining compartments and/or spaces;
- protect a compartment interior from external fire attack, e.g. fire spread across the building's facade or from an adjacent building;
- minimize adverse, or harmful, environmental impacts outside the building

NOTE In a fire situation, fire-induced progressive collapse may commence before any breach of "integrity" occurs in the boundary of a fire compartment.

### 3.21

#### **fire defence plan**

operational guide for a specific building comprising fire engineering drawings, descriptive text, fire safety related product/system information, with supporting calculations and fire test data developed from the fire engineering strategy

### 3.22

#### **fire engineering strategy**

coherent and purposeful arrangement of fire prevention, fire protection and fire management measures which is developed in order to attain specified fire engineering design objectives

NOTE Some "fire safety objectives" may be required by legislation.

### 3.23

#### **fire prevention**

all measures necessary to prevent an outbreak of fire in a building, including such secondary activities as fire research and education of the public concerning fire hazard

### 3.24

#### **fire protection**

use of spatial planning, building design, construction, services, systems, personnel and equipment in order to control and extinguish fire, and minimize any adverse or harmful environmental impacts caused



### 3.25

#### **fire resistance**

ability of an element of construction to withstand heat, smoke and flame or give protection from them for a period of time

NOTE Adapted from ISO 13943:2008.

### 3.26

#### **fire resisting doorset**

doorset, properly installed or mounted on site, the function of which is to resist the passage of heat, smoke and flame for a specified time during a fire

### 3.27

#### **going**

tread

(stair) horizontal distance between two consecutive nosings, measured on the centre line

### 3.28

#### **going**

(ramp) horizontal distance between the start and finish of a flight of a ramp

### 3.29

#### **guiding pattern**

tactile walking surface indicators (TWSIs) to indicate a direction of travel

### 3.30

#### **habitable room**

room, intended for dwelling purposes, including a kitchen, a bathroom and a utility room

### 3.31

#### **handrail**

component of a stair or of a ramp or other building components that provides guidance, balance and support

NOTE Adapted from ISO 6707-1:2004, 5.2.73.

### 3.32

#### **hearing enhancement system**

piece of equipment, product system, hardware, software or service that is used to increase, maintain or improve listening capabilities of individuals with hearing impairments

### 3.33

#### **impairment**

limitation in body function or structure such as a significant deviation or loss which can be temporary due, for example, to injury, or permanent, slight or severe and can fluctuate over time, in particular, deterioration due to ageing

NOTE 1 Body function can be a physiological or psychological function of a body system; body structure refers to an anatomic part of the body such as organs, limbs and their components (as defined in ICIDH-2 of July 1999).

NOTE 2 This definition differs from that in ISO 9999:2007, taken from ICF 2001, WHO: "problems in body function or structure, such as a significant deviation or loss".

NOTE 3 Adapted from ISO/TR 22411:2008.

### 3.34

#### **impairment, cognitive**

deficiency of neuropsychological function which can be related to injury or degeneration in specific area(s) of the brain

### 3.35

#### **impairment, mental**

slower than normal rate in a person's cognitive developmental maturation, or where the cognitive processes themselves appear to be slower than normal, with an associated implication of reduced, overall mental potential

### 3.36

#### **kerb ramp**

construction, in the form of an inclined plane that makes it possible to pass from street level to a higher pedestrian path

### 3.37

#### **keypad**

arrangement of buttons or touch pads with numbered keys in accordance with the standard telephone layout

### 3.38

#### **landing**

platform or part of a floor structure at the end of a flight of stairs or a ramp or at the entrance to a lift car

NOTE Adapted from ISO 6707-1.

### 3.39

#### **levelling accuracy**

maximum vertical distance between a car sill and a landing sill during loading or unloading of the lift

### 3.40

#### **lifting platform**

device permanently installed to serve fixed landing levels, comprising a guided platform whose dimensions and means of construction permit the access of disabled passenger(s), with or without wheelchair(s)

[ISO 9386-1, definition 3.2.5]

### 3.41

#### **light reflectance value**

#### **LRV**

proportion of visible light reflected by a surface at all wavelengths and directions when illuminated by a light source

NOTE 1 LRV is also known as the luminance reflectance factor or CIE Y value (see International Commission on Illumination, CIE, Publication 15:2004, 3<sup>rd</sup> Edition, *Colorimetry*).

NOTE 2 The LRV is expressed on a scale of 0 to 100, with a value of 0 points for pure black and a value of 100 points for pure white.

### 3.42

#### **LRV, differences in**

values used to assess the degree of visual contrast between surfaces such as floors, walls, doors and ceilings and between key fittings/fixtures and surrounding surfaces

### 3.43

#### **luminance**

intensity of light emitted or reflected in a given direction from the surface element divided by the area of the element in the same direction

NOTE Adapted from ISO 6707-1.

### 3.44

#### **manoeuvring zone**

minimum three dimensional space within which it is feasible to complete a manoeuvre needed to gain access to a specific facility, component or fitting, in particular while using a wheelchair or a walking aid

**3.45**

**moving walkway**

moving accessible path of travel, either level or with an inclination up to 6°

**3.46**

**nosing**

projecting front edge of a tread or landing that can be rounded, chamfered or otherwise shaped

NOTE Adapted from ISO 6707-1.

**3.47**

**place of relative safety**

location beyond the buffer zone surrounding a fire compartment in a building

**3.48**

**place of safety**

location beyond a perimeter which is a safe distance from the building and where necessary medical care and attention can be provided, or organized, within one hour of injury and where people can be identified

**3.49**

**principal entrance**

entrance or, if there is more than one with equal status, the entrances that people would normally expect to approach and to enter in order to use the building or other facility

**3.50**

**principal entrance storey**

(building) storey that contains the principal entrance or principal entrances to the building

**3.51**

**ramp**

construction, in the form of an inclined plane that is steeper than or equal to 1:20 (5 %) from the horizontal, together with any intermediate landing, that makes it possible to pass from one level to another

NOTE Adapted from ISO 6707-1.

**3.52**

**reflectance**

measure of light reflected in a given direction by a surface (in its installed environment) and which is expressed in a unit term from 0 to 100 on a scale, respectively, that represents a greyscale progression from the notional extremes of total light absorption (black) to total light reflection (white)

**3.53**

**rise**

vertical distance between the upper horizontal surfaces of two consecutive treads, or of a landing and the next treads above or below it, or of a flight between consecutive landings

NOTE Adapted from ISO 6707-1.

**3.54**

**riser**

vertical component of a step between a tread or a landing and the tread or landing above or below it

NOTE Adapted from ISO 6707-1.

**3.55**

**stair lift**

appliance for transporting a person (either seated or standing) or a person in a wheelchair between two or more landings by means of a seat or platform moving in an inclined plane

NOTE Adapted from EN 81-40.

### 3.56

#### **stopping accuracy**

maximum vertical distance between the car sill and landing sill at a moment when a car is stopped by the control system at its destination floor and the doors reach their fully open position

### 3.57

#### **suitable**

(built environment) appropriate design, construction, installation or location meeting the needs of the intended user

### 3.58

#### **tactile walking surface indicator**

##### **TWSI**

profiled paving surface with visual contrast criteria to enable a person with impaired sight using a long cane, underfoot or visual identification to detect a specific route (guiding pattern) or the presence of a hazard (attention pattern)

NOTE See Annex A.

### 3.59

#### **unobstructed width**

(general) free unobstructed space necessary for passage through a doorway, along a passageway, or other route element (e.g. stairway)

### 3.60

#### **unobstructed width**

(door) available width for passage through a door opening, clear of all obstructions below 900 mm, measured when the door is opened 90°, or when a sliding or folding door is opened to its fullest extent

NOTE The definition of clear opening width in ISO 1804 defines another concept, the smallest distance between rebates, which is different from unobstructed width.

### 3.61

#### **usability**

characteristic of the built environment which can be used by everybody in convenience and safety

### 3.62

#### **user**

person who interacts with the product, service or environment

[ISO/TR 22411:2008, definition 3.3]

### 3.63

#### **visual contrast**

visual perception between one element of a building and another

NOTE This can be produced by a difference in LRV or luminance, also called luminance contrast.

### 3.64

#### **wayfinding**

descriptive of a system whereby appropriate information is provided to assist a person to pass through the built environment towards a specific destination

NOTE Wayfinding includes orienting oneself, knowing one's destination, following the best route, recognizing one's destination and finding one's way back out. People who are blind or who have a vision impairment benefit from tactile information to facilitate wayfinding.

## 4 General design considerations

### 4.1 General

The requirements in this International Standard relate to the principal human abilities that should be considered when designing, constructing and managing the built environment. These abilities are described in Annex B which gives an overview of design considerations that should be taken into account for each of the different abilities.

### 4.2 Design requirements according to human abilities

When fully implemented, this International Standard is expected to be of benefit to all people, including:

- people with hearing impairments,
- people with vision impairments,
- people with mobility impairments,
- people with cognitive impairments,
- people with hidden (such as strength, stamina, dexterity and allergy) impairments, and
- people with diversities in age and stature (including frail persons).

### 4.3 Key accessibility issues

Entering, using and evacuating buildings should be safe and easy for individuals, families and groups which include persons with disabilities.

The main considerations are:

- pedestrian access into site,
- designated cycle and motor vehicle parking near the main entrance,
- accessible path to the entrance,
- appropriate external lighting,
- accessible external furniture (seats, bins, etc.),
- accessible information at the entrance to the site,
- suitable drop-off point near main entrance,
- reduced travelling distances,
- level entrances and exits,
- simple and logical layouts,
- unobstructed level circulation,
- easy access to information desks, lifts and toilet compartments for disabled persons,
- intuitive, obvious and accessible fire evacuation routes,
- spacious lifts,
- safe stairs that are easy to use, and facilitate safe assisted evacuation/rescue in emergencies,
- slip-resistant walking surfaces,

- wide door openings and easy door operation, sufficient space around doors that makes it possible to open and close them when seated in a wheelchair,
- adequate manoeuvring space,
- adequate height, location and easy operation of controls and switches,
- good lighting,
- good visual contrast of walls, floors, doors and signage,
- good signage,
- important information communicated via two senses or more (tactile, audible and visual),
- good acoustics,
- hearing enhancement systems,
- management and maintenance of the built environment.

See Table 1 for examples of how these issues can be combined when planning a built environment.

**Table 1 — Examples of key accessibility issues in the early stages of planning**

No.	Key accessibility issues	Example
1	<p>Equitable approach to a building, e.g. designated parking, clear pedestrian routes separate from vehicles and cyclists, no steps or obstacles, short distances from parking and public transport, good signage, good lighting and good contrast.</p> <p>See Clauses 5, 6, 7, 8, 9, 33, 35 and 40.</p>	
2	<p>Equitable entry via the same entrances, e.g. easy to locate main entrances, no steps or obstacles, wide openings, adequate manoeuvring space in front of the door, low operating forces, good signage, good lighting and good visual contrast.</p> <p>See Clauses 10, 18, 33, 35, 36 and 40.</p>	
3	<p>Equitable use of the same paths in horizontal circulation, e.g. no steps or obstacles, adequate manoeuvring space, wide door openings, easy to operate doors, resting places, clear layout, good signage, good lighting and good visual contrast.</p> <p>See Clauses 11, 18, 33, 35, 37 and 40.</p>	

Table 1 (continued)



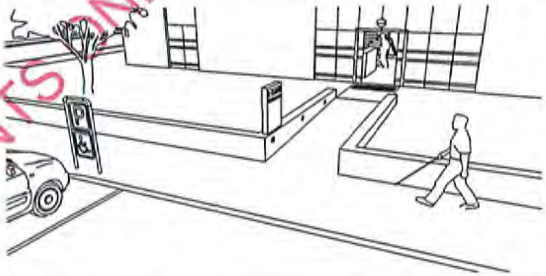
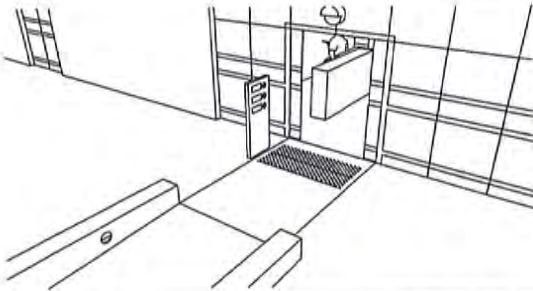
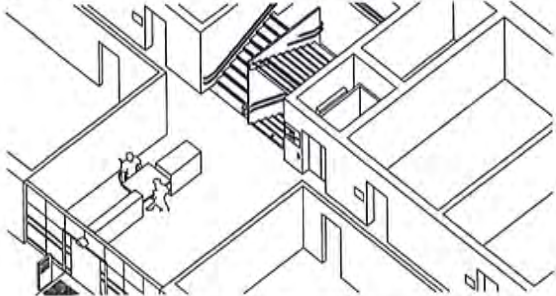

No.	Key accessibility issues	Example
4	<p>Equitable access to the same paths in vertical circulation, e.g. safe stairs, spacious lifts with easy operation, good signage, good lighting and good visual contrast.</p> <p>See Clauses 12, 13, 14, 15, 17, 33, 35 and 40.</p>	
5	<p>Equitable use of the same rooms, e.g. ample circulation space and different seating possibilities, good acoustics and hearing enhancement systems, good lighting and good visual contrast.</p> <p>See Clauses 21, 22, 23, 24, 25, 32, 33 and 35.</p>	
6	<p>Equitable use of the same equipment and facilities, e.g. easy to understand and operate, adequate manoeuvring space and operating height, information via two senses.</p> <p>See Clauses 11, 19 and 36.</p>	
7	<p>Equitable use of toilet and sanitary facilities, e.g. good signage, adequate manoeuvring space, good transfer options, well-placed equipment, easy operation.</p> <p>See Clauses 26, 39 and 41.</p>	

Table 1 (continued)

No.	Key accessibility issues	Example
8	<p>Equitable exit and evacuation routes, concepts for emergency planning, e.g. no steps or obstacles, fire protected lifts/elevators, good signage, good lighting, good visual contrast, good fire safety, protection and evacuation, accessible evacuation routes.</p> <p>See Clauses .15, .33, 34, 35, 38 and .40.</p>	 <p>The diagram illustrates a fire-protected lift shaft. At the top, a person is shown being lowered. In the middle, a person in a wheelchair is being transported. At the bottom, a person is shown being lowered. The shaft is enclosed in a fire-protected structure, and there are clear exit routes on either side.</p>
9	<p>Important information via two senses or more, e.g. visual, audible and tactile.</p> <p>See Clauses 39 and .40.</p>	 <p>The diagram shows a door to a toilet. Above the door is a large wheelchair symbol. Below the symbol, the word "Toilet" is written in a large, clear font. Underneath the word, there is a row of Braille characters.</p>

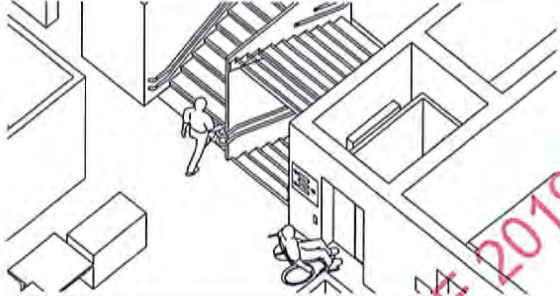
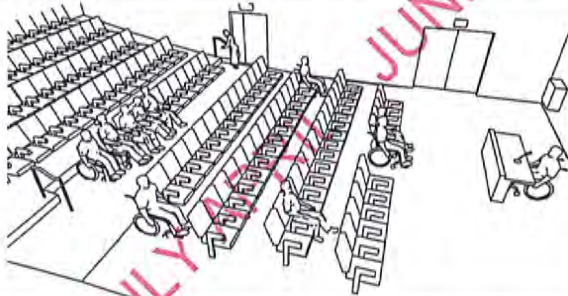
## 5 Approach to the building

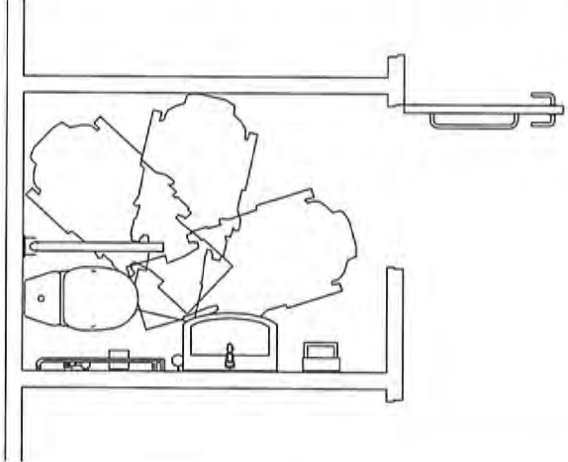
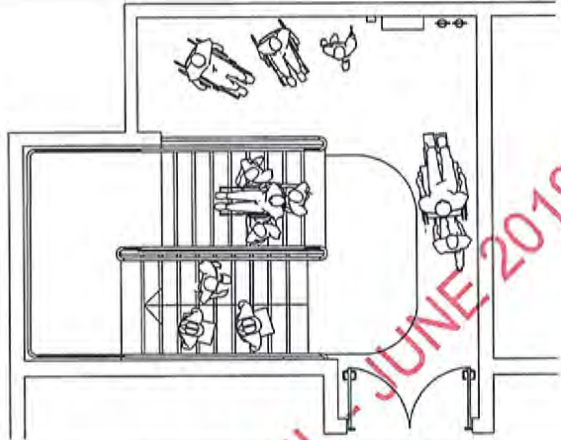
### 5.1 Arrival by motor vehicle

Space should be provided for passenger drop-off points for taxis, public transport and also for large vehicles such as vans, etc., as near as possible to the main accessible entrance. Vehicle drop-off areas should be a minimum of 9 000 mm in length, have a minimum width of 3 600 mm and be served by a kerb ramp.

See designated accessible parking space in Clause 6.

### 5.2 Principal entrance

If there is a difference in level between the carriageway and the footpath, a kerb ramp (see 8.2) shall be provided to facilitate the setting-down of people close to the principal entrance of a building. This benefits people who need to transfer to and from a wheelchair and others.

An appropriate tactile walking surface indicator (TWSI) should be provided to lead vision impaired persons to the main entrance where no other clues indicate the path to the building. See example in Figure 4.



## **6 Designated accessible parking space**

### **6.1 Location**

The designated parking spaces shall be located as near as possible to the principal entrance, and the route from the accessible parking space to the main entrance should be less than 50 m.

### **6.2 Number of designated accessible parking spaces**

If no national requirements or regulations are available, the following minimum requirements concerning the number of parking places shall apply:

- a minimum of one accessible designated parking space should be provided in every parking area,
- up to 10 parking spaces: one designated accessible parking space,
- up to 50 parking spaces: two designated accessible parking spaces,
- up to 100 parking spaces: four designated accessible parking spaces,
- up to 200 parking spaces: six designated accessible parking spaces,
- over 200 parking spaces: six designated accessible parking spaces + one for each additional 100.

In specialized facilities such as health care facilities, shopping areas and recreational facilities, a greater number of designated accessible parking spaces should be considered.

Additionally, some designated accessible parking spaces should be provided for motorists accompanied by a child in a perambulator or pushchair and shall be designated with a perambulator sign.

### **6.3 Car parking**

The minimum width of the parking space for a car shall be 3 900 mm and the minimum length shall be 5 400 mm. This minimum width includes the transfer area beside the car with a minimum of 1 500 mm. Figure 1 shows one single parking bay and aisle.

Two accessible parking spaces with one shared transfer area are widely used and shall have a minimum width of 6 300 mm (see Figure 1).

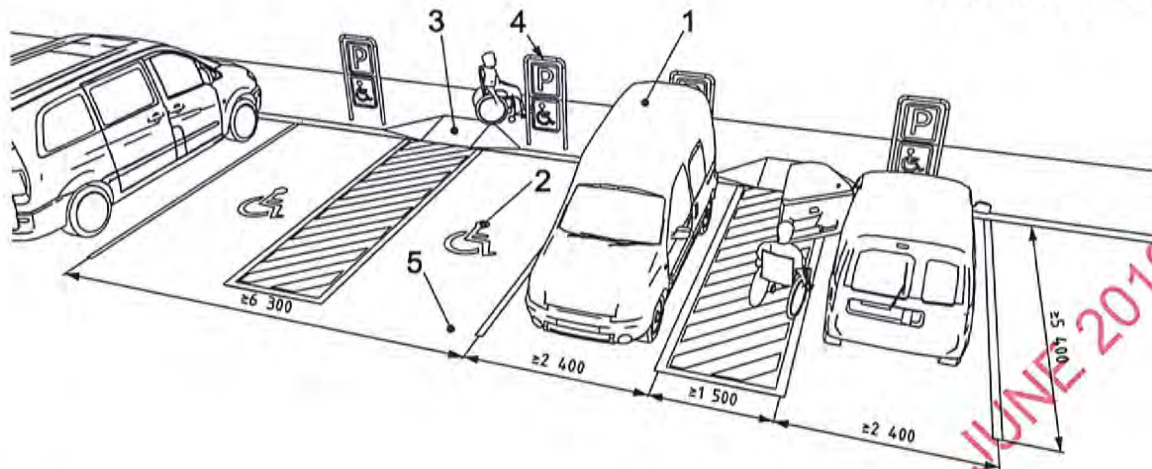
**Key**

- 1 minimum unobstructed height for vans 2 600 mm
- 2 symbol of access
- 3 kerb ramp
- 4 signage, including symbol of access
- 5 firm ground

**Figure 1 — Examples of designated parking spaces**

#### 6.4 Van parking with auxiliary movable ramps

The size and design of accessible vehicles varies from country to country. Some are fitted with ramps or hoists at the side or at the rear. National standards should be used where they exist.

The minimum width of the accessible parking space for a van shall have at least the same dimensions as for car parking spaces (see 6.3). Transfer areas between spaces can be shared.

For multi-purpose vehicles with hoists or lifts, more space is needed; at least an additional 2 400 mm area beside the van and/or at the rear of the van. The dedicated parking space in this case shall be 4 800 mm wide and 9 000 mm long (see different types of designated parking spaces in Figures 1 and 2).

As an alternative, a parking space of 2 400 mm wide × 9 000 mm in length along a sidewalk can be used, provided the sidewalk is at least 2 400 mm wide as shown in Figure 2.

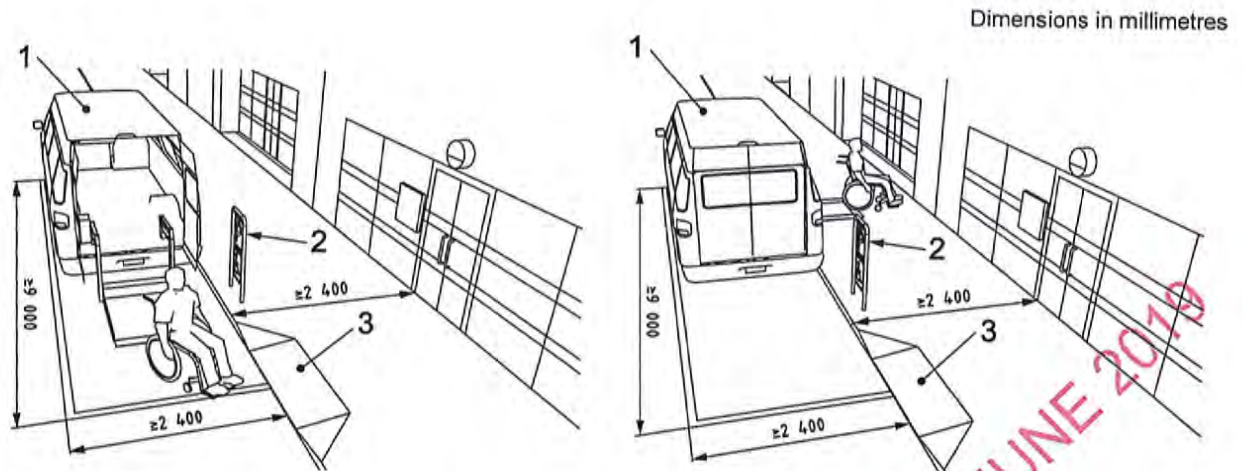

#### Key

- 1 minimum unobstructed height 2 600 mm
- 2 signage, including symbol of access
- 3 kerb ramp

Figure 2 — Example of parking space along a sidewalk

### 6.5 Signage

It is important that the locations of the designated parking spaces are clearly signposted at the entrance to the building site or car park with information providing direction to designated parking spaces and to other accessible facilities. Therefore, directional arrows combined with the international symbol of access (see Figure 66) shall be used.

Designated accessible parking spaces shall be marked both on the pavement with the international symbol of access (see Figure 66) and with a vertical sign with the international symbol for accessible parking space to indicate the location of the designated accessible parking. The vertical sign should be located so that it does not create a hazard (see Figure 2).

### 6.6 Surface

The accessible parking space shall be on firm and level ground with no variation of surface exceeding 5 mm, between paving, surface features and mix of different surfaces or finishes.

The designated accessible parking spaces shall be located on a gradient not greater, throughout its length and its width, than 1:50.

### 6.7 Kerb ramp from parking space to an adjacent higher pedestrian path

The kerb ramp should be located in close proximity to the designated accessible parking area connecting the accessible path of travel to the principal entrance.

The kerb ramp width should be a minimum of 1 000 mm. The gradient of the kerb ramp should consider the requirements in Clause 8 and comply with Table 2.

The accessible path to the kerb ramp can be marked with hatching painted on the road surface to prevent people from parking in this area (see Figures 1 and 2).

Kerb ramps shall have a slip-resistant surface.

## 6.8 Indoor parking

### 6.8.1 General

If no national requirements or regulations are available, the minimum requirements outlined in 6.1 to 6.6 also apply for indoor parking facilities.

If an indoor parking facility is not accessible, suitable warnings shall be given at the entrance and alternative designated accessible parking spaces shall be provided outside the building.

### 6.8.2 Signage at the entrance to parking spaces

Signage should be posted at the entrance to any parking area indicating the location of the designated accessible parking spaces.

Suitable indication shall be provided for the route from the accessible designated parking space to the building or buildings served by the car park, including to parking machines, passenger lifts, ramps, exits and any accessible devices or services (e.g. accessible toilets).

### 6.8.3 Location of designated accessible parking spaces

Designated accessible parking spaces shall be located at the same level as the principal entrance or other entrance to the building or buildings served by the car park.

Designated accessible parking spaces should be signposted.

A suitable passenger lift or separated pedestrian ramp shall be installed to provide access from the parked vehicle to the principal entrance of the building or buildings served by the car park. A lift should also be provided for use by people parked in non-designated spaces.

Location of accessible parking spaces (indoor parking) should be as close as possible to the entrances/lifts.

### 6.8.4 Height of clearance

The clearance height at the entrance to parking facilities should be a minimum of 2 400 mm.

NOTE National building regulations can have other dimensions reflecting the height of local transportation vehicles.

## 6.9 Parking control

If a payment machine is provided it shall provide all controls at a height between 800 mm and 1 100 mm. Clause 36 shall be considered.

Access to the machine shall be level along an accessible route and easy to operate. The machine shall be located so that it does not create a hazard or barrier for people with vision impairments or people with mobility impairments.

## 7 Paths to the building

### 7.1 General

The design of the path or route to the building from the boundary of the site or from the parking area should be designed and constructed to enable all people to approach, enter and exit the building (see Figure 3 and Annex A).

Where a kerb ramp is located in the direct line of pedestrian travel, the dished area of the kerb shall be fitted with tactile warning surface indicator (attention pattern). See Annex A for further information.

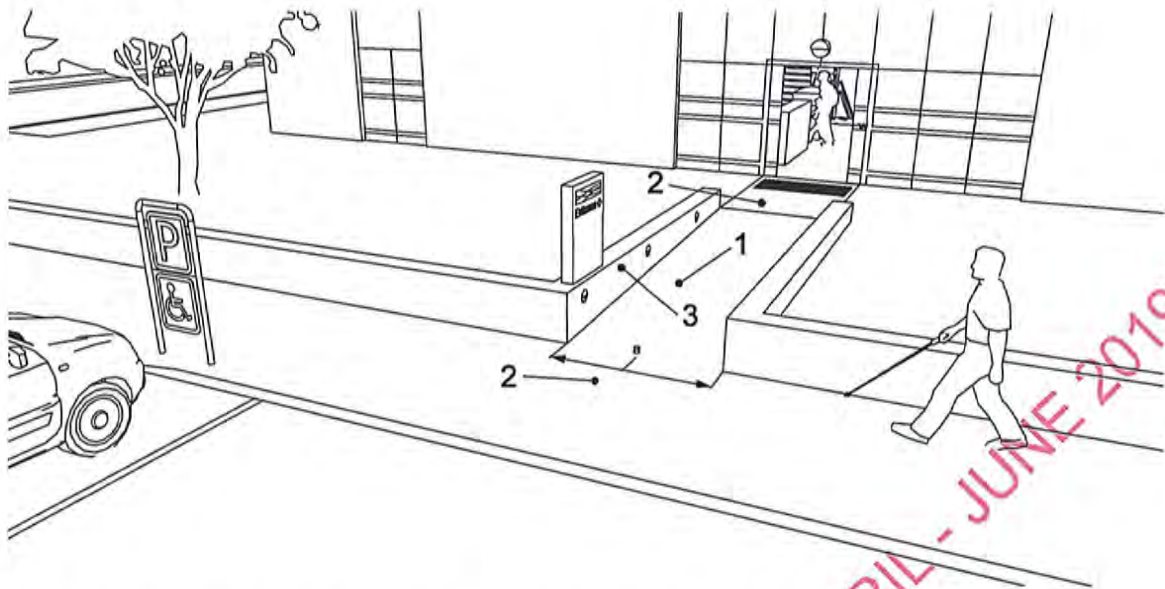

#### Key

- 1 sloping path (when the slope is steeper than 1:20 (5 %) the path shall be constructed as a ramp)
  - 2 horizontal landing at both ends of sloping path, intermediate landings spaced according to Table 2
  - 3 wall as tactile clue on direction
- <sup>a</sup> Width of sloping path min. 1 200 mm.

Figure 3 — Example of sloping path

Pedestrian paths or routes should be separated from routes used by cyclists and motor vehicles. Where necessary, crossing points should be provided with appropriate kerbs and TWSI.

Access between buildings shall also comply with this subclause.

### 7.2 Wayfinding, guided path and other physical support of information

Suitable provision shall be made at the entrance to the site and from any car parking within the site and at decision points within the site to indicate the location and nature of the path to the building.

In very complex sites, visual, audible and tactile information should be provided to assist in orientation and wayfinding. The requirements in Clause 39 should also be considered.

Orientation can be facilitated by differences in acoustics, surface material, light and colour. The design should indicate the use of the building elements, especially the location of the main entrance, making it clearly visible.

Additional illumination or visual contrast and tactile information, such as a change in material or tactile walking surface indicators (see Annex A), shall be provided at key decision points to assist orientation and wayfinding.

To assist people with vision impairment who have some residual vision, routes to be followed shall have a minimum difference in luminance to the surroundings (see Clause 35).

Tactile walking surface indicators shall be used to indicate the directional orientation especially where no other clues indicate the path to the building. Across large or open areas, people who are blind need a tactile route or guiding line to follow (see Annex A).

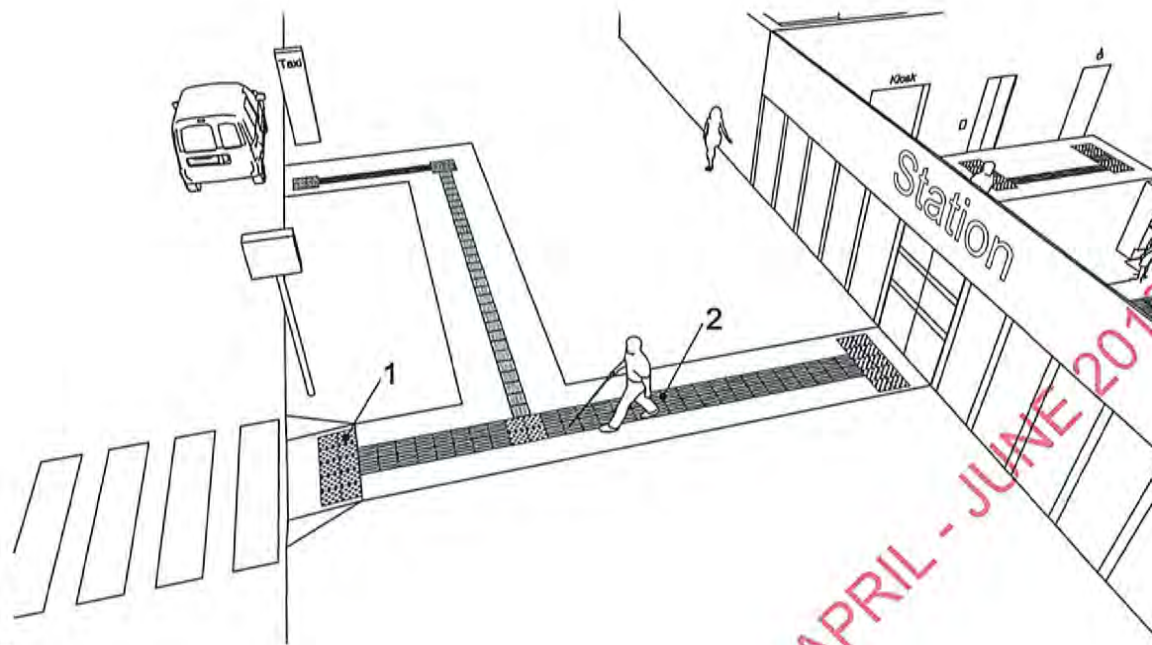

**Key**

- 1 tactile walking surface indicator as attention pattern for decision points or hazards
- 2 tactile walking surface indicator as guiding pattern

**Figure 4 — Example of tactile walking surface indicators used in open area**

Where hazards on the direct line of pedestrian travel such as stairs, escalators, moving walks and travelators or ramps with a slope of more than 1:16 cannot be avoided, tactile warning indicators and visual markings shall be provided.

To assist orientation and wayfinding, the requirements in Clause 39 should also be considered.

NOTE 1 Tactile floor coverings or a runner as well as tactile walking surface indicators can help in locating entrance doors, counters, etc.

NOTE 2 Sound-producing objects (such as ticking wall clocks and fountains) can provide a good way to find aid for people who are blind or have vision impairment and can supplement tactile information. These provisions are particularly aimed at people with a combination of sensory impairments.

**7.3 Path**

The path to, around and between buildings should be level and firm.

The cross fall gradient across an access route should not exceed 1:50 (20 mm/m), except when associated with a dropped kerb. See 7.13 for requirements on drainage of paths.

If the slope or any part of a path on an accessible route to a building exceeds 1:20, it shall be designed and constructed as a ramp (see Clause 8).

Obstacles, such as objects or signs mounted on walls, bollards, columns or free-standing supports along the walking path should be avoided. Unavoidable free standing posts or columns within access routes shall be clearly marked with visual indicators. Visual indicators at least 75 mm in height with a minimum visual contrast of 30 points difference to the background shall be placed at a height between 900 mm – 1 000 mm and 1 500 mm – 1 600 mm above floor level.

Any solitary obstacles projecting into an access route shall be treated in accordance with 7.14.

## 7.4 Width of the path

The unobstructed width of the path shall be (see Figure 5):

- not less than 1 800 mm for constant two-way traffic;
- not less than 1 500 mm for frequent two-way traffic, provided that passing places are included at intervals of maximum 25 m;
- not less than 1 200 mm for infrequent two-way traffic; a passing and turning space of at least 1 800 mm × 2 000 mm should be provided for every 25 m (see 7.5)
- not less than 900 mm when it is unlikely that people will have to pass one another; a turning space of at least 1 800 mm × 2 000 mm should be provided for every 25 m (see 7.6).

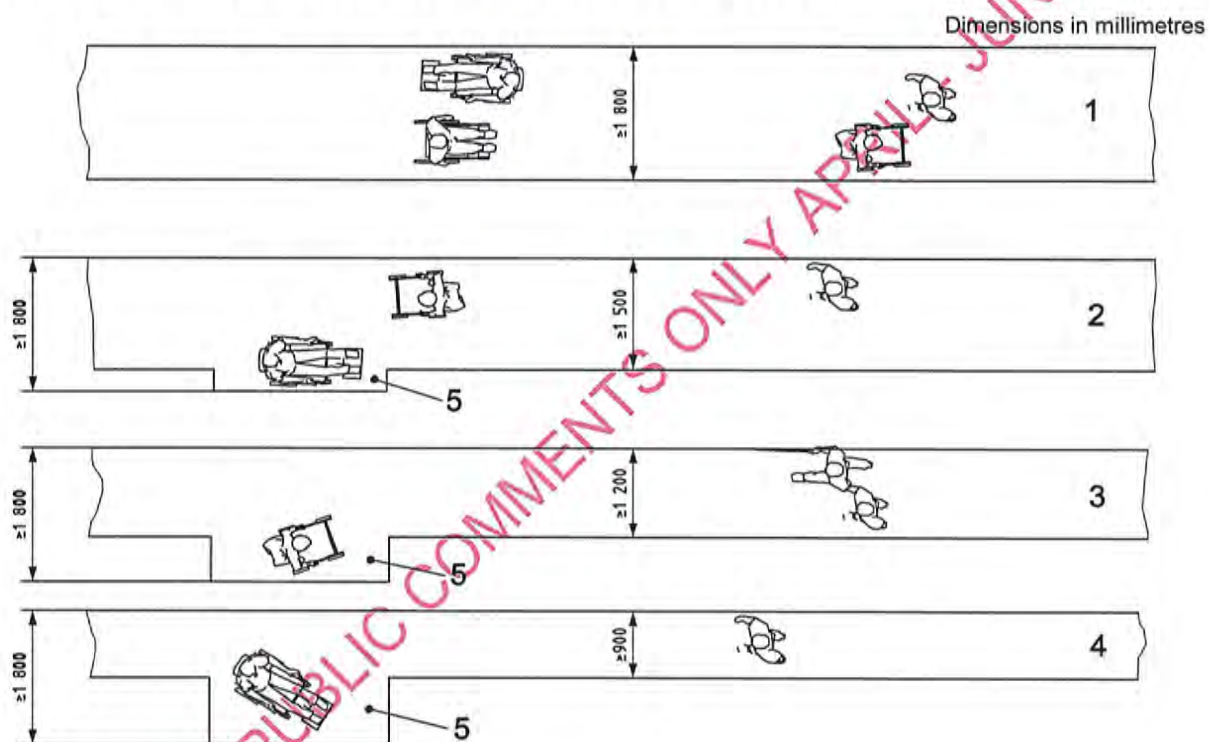

### Key

- constant two-way traffic
- frequent two-way traffic
- infrequent two-way traffic
- no-pass traffic
- passing and turning space every 25 m (only acceptable for wheelchair users under exceptional circumstances)

Figure 5 — Different surface widths of the path depending on frequency

## 7.5 Passing space for wheelchair users

A path whose surface width is less than 1 800 mm (see 7.4) and whose overall length is more than 50 m, shall be provided with a passing place or places. Passing places should be a maximum of 25 m apart. This does not apply to a landing forming part of a sloped path, a ramp, steps or a stair.

Passing place for two people using wheelchairs shall be a minimum width of 1 800 mm for a minimum length of 2 000 mm (see examples in Figure 6).

NOTE Passage widening can be associated with intersections, turns and doorways so as to appear as integrated design features or enhancements.

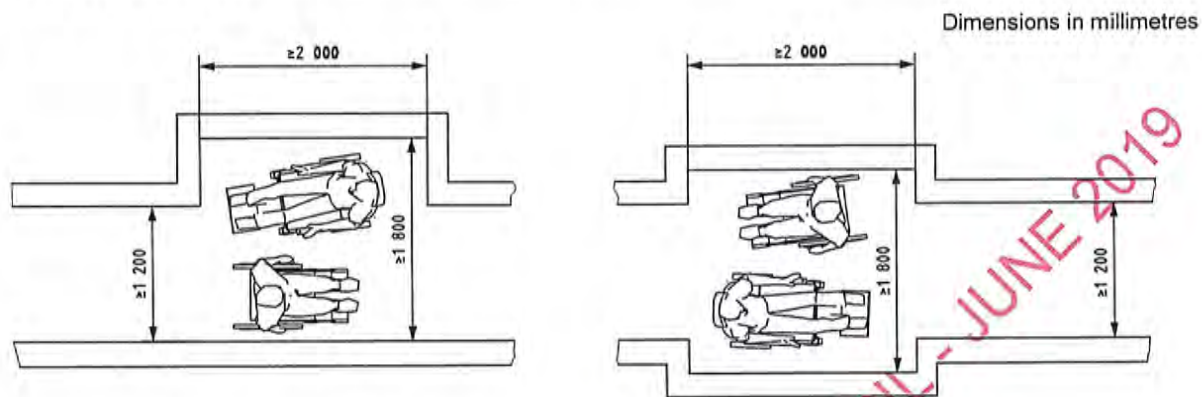

Figure 6 — Examples for passing spaces for wheelchair users

## 7.6 Turning space for wheelchair users on landings

For changes of direction of more than 45° on the landings of the path to the building, the unobstructed manoeuvring space shall be at least 1 500 mm × 1 500 mm. See similar requirements for ramps in Clause 8.

If larger powered wheelchairs and scooters for outdoor use are to be considered, the outer radius of a turning space should be larger. In such cases, for changes of direction of more than 45° on the landings of the path to the building, the radius of the outer circle of the way shall be at least 1 900 mm for powered wheelchairs and scooters.

## 7.7 Path construction

The path shall be firm with an even and slip-resistant surface and should be free from drainage gratings.

Care shall be taken to ensure that adjacent surface materials do not display different slip resistance characteristics, particularly at the edges of changes of level or gradients.

## 7.8 Stepped path and stair

For ambulant people, a stepped path can provide a safer and more assuring means of access than a sloped path or a ramp.

Wherever the rise of a ramp exceeds 300 mm, an additional flight of steps should also be provided.

An isolated single step is not acceptable.

Consider detailed requirements for stairs according to Clause 13.

Where required on a continuous accessible path of travel, tactile warning indicators shall be located at both the top and bottom of stairways.



## 7.9 Width of stepped path and stair

The surface width of a stepped path and stair shall be not less than 1 200 mm. The clear unobstructed width of the flight of a single- or multi-channelled stepped path and stair shall be not less than 1 000 mm between handrails or any obstructions.

## 7.10 Landing of stepped path and stair

For requirements for landings see also 13.3.

## 7.11 Landings of sloped paths

For landings at the foot and the head of a sloped path, see also 8.4. If there is a door at the end of the landing of a sloped path, the manoeuvring area, door opening area and access to the door handle should also be considered.

## 7.12 Support and guidance by a handrail on paths

Where handrails and guards are used on paths, the requirements included in Clauses 9 and 14 should be considered.

Support and guidance by a handrail should be provided on stepped paths:

- a handrail shall be provided on each side of a flight of steps that consists of two or more risers.
- a handrail shall be provided on both sides of a channel that may subdivide a flight of steps.

## 7.13 Drainage of access routes

The cross-fall of a level or sloped path, a stepped path, a ramp, or a landing, that is provided to permit drainage of surface water, should not exceed 1:50 except in exceptional circumstances.

A dished channel should not be constructed within the boundaries of a path or ramp.

Dished channels shall have a maximum width of 150 mm and a maximum drop into gully of 5 mm.

A drainage grating that is within the boundaries of a path or a ramp shall be set flush with the surface.

The top, bottom and landings of steps and ramps should be properly drained in order to avoid water flowing down steps and ramps.

## 7.14 Solitary obstacles in a path

Objects with a height lower than 1 000 mm can create a hazard for blind or partially sighted people. Permanent equipment that cannot be located outside the boundaries of a path shall be:

- a) designed to be easily seen with a minimum difference in LRVs of 30 points to the background, and
- b) shielded to protect against impact, and
- c) accompanied by a feature that warns of the presence of a potential hazard and is detectable for a person using a white cane or stick (see Figure 7).

The headroom along a path shall be maintained at a height of not less than 2 100 mm above the surface of the path.

Any objects projecting more than 100 mm between 300 mm and 2 100 mm above ground level into an access route shall be clearly visible and detectable with a cane (see Figure 7).

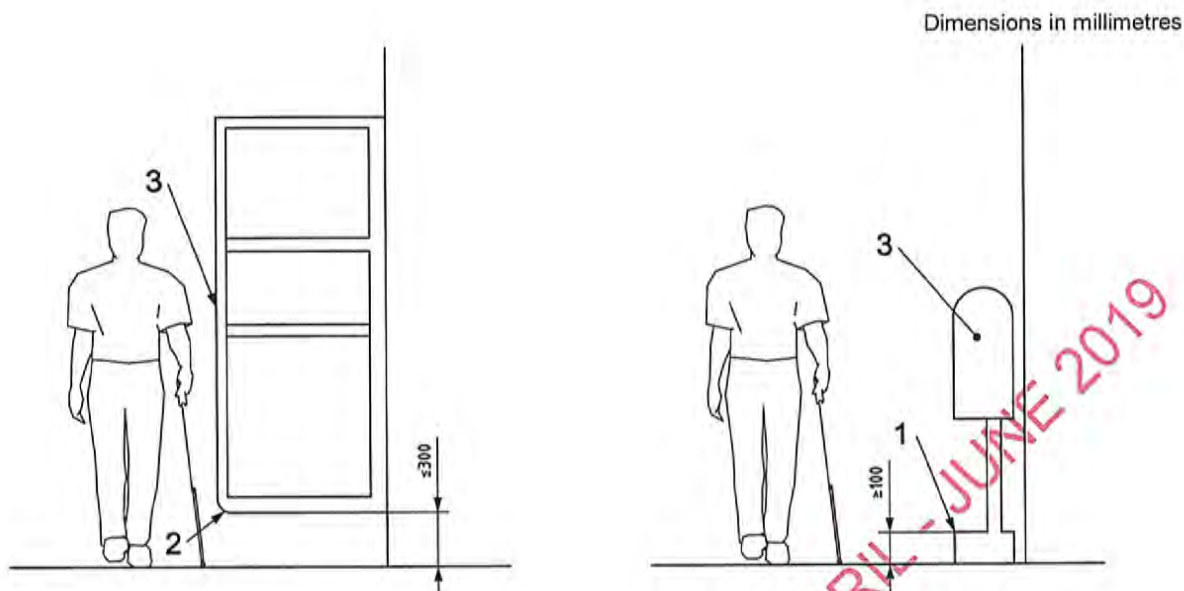

#### Key

- 1 base plinth detectable with cane if a projecting object is more than 100 mm above floor level
- 2 winged protection between 300 mm and 1 000 mm above floor level, contrasting visually with the background and detectable with a cane
- 3 difference in light reflectance value to background – minimum 30 points

**Figure 7 — Solitary obstacles**

When a projecting obstacle exists, a protective guard shall be provided at ground level, under the projecting object such as a kerb or fixed element at a height of 100 mm – 300 mm as cane detection. Cane detection shall not be set back more than 100 mm from the face of the projecting object. Wing walls, side partitions, alcoves or recesses are solutions for projecting elements where free space under the object is needed. Winged protection shall extend continuously between 300 mm and 1 000 mm above the floor and shall contrast visually with the background.

### 7.15 Guards against falling within a path

See the requirements in Clause 9.

## 8 Ramps

### 8.1 General

Ramps provide an accessible route between changes of level. A ramp with the appropriate slope can provide accessibility without requiring reliance on a mechanical device.

Ramps may be the only practical solution for people who cannot use steps or stairs, but other people may prefer to use stairs.

In addition to a ramp, a flight of steps should be provided if the change in level is more than 300 mm (see Figure 8).

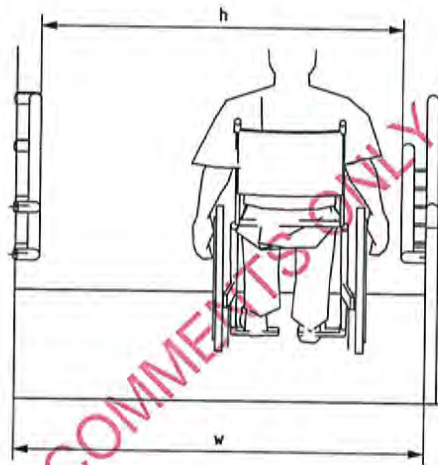
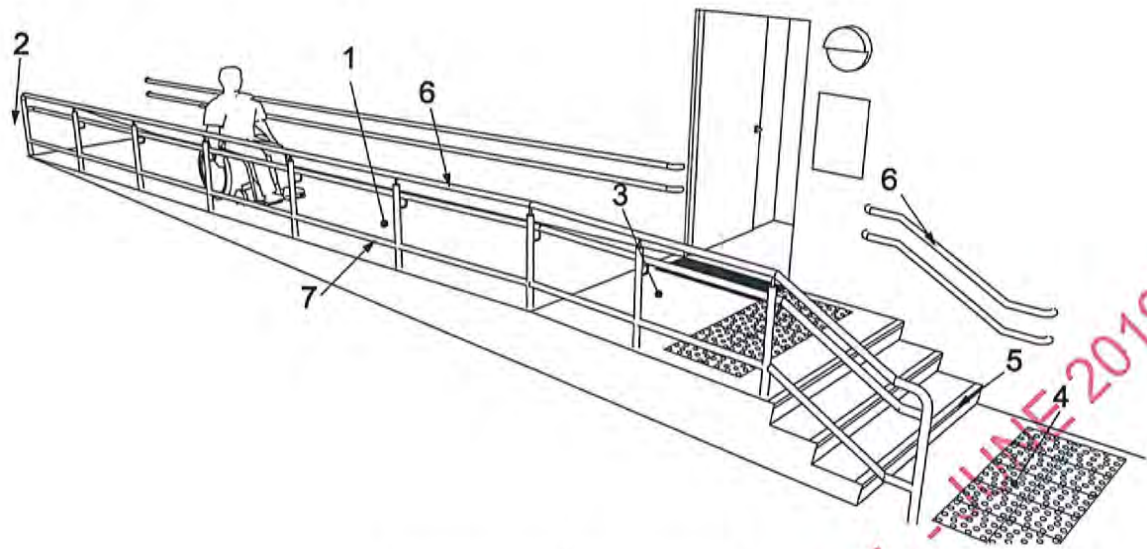

**Key**

- 1 ramp surface (see Table 2 for maximum slope and length)
- 2 horizontal landing
- 3 horizontal landing
- 4 tactile walking surface indicator in front of stairs
- 5 complementary stairs with markings
- 6 handrails on both sides of ramp and stairs
- 7 upstand, min. 150 mm
- h width between handrails
- w width of ramp surface

**Figure 8 — Example of ramp with slope 1:20 and horizontal landings at beginning and end**

In buildings of more than one storey, a lift should be provided (see 15.1).

Where required on a continuous accessible path of travel, tactile warning indicators should be located at both the top and bottom of ramps. See further detailed measures in 13.5.

## 8.2 Slope and length

The slope shall not exceed the maximums set out in Tables 2 and 3.

**Table 2 — Maximum slope and length of ramps**

Max. rise, mm	Max. slope	Max. slope, mm/m	Max. length between landings, mm	Outdoor use	Indoor use	Handrails required
no limit	Less than 1 in 20 (5,0 %)	<50	no limit	yes	yes	no
500	1 in 20 (5,0 %)	50	10 000	yes	yes	see 8.5
460	1 in 19 (5,3 %)	53	8 740	yes	yes	see 8.5
420	1 in 18 (5,6 %)	56	7 560	yes	yes	see 8.5
385	1 in 17 (5,9 %)	59	6 545	yes	yes	see 8.5
350	1 in 16 (6,3 %)	63	5 600	yes	yes	see 8.5
315	1 in 15 (6,7 %)	67	4 725	yes	yes	see 8.5
280	1 in 14 (7,1 %)	71	3 920	yes	yes	see 8.5
245	1 in 13 (7,7 %)	77	3 185	yes	yes	see 8.5
210	1 in 12 (8,3 %)	83	2 520	yes	yes	see 8.5
180	1 in 11 (9,1 %)	91	1 980	kerb ramps only	not recommended	no
150	1 in 10 (10,0 %)	100	1 500	kerb ramps only	not recommended	no
110	1 in 9 (11,1 %)	111	990	kerb ramps only	not recommended	no
75	1 in 8 (12,5 %)	125	600	kerb ramps only	threshold ramps only	no

NOTE A ramp with a gradient higher than 1:12 is difficult to use and can create a risk of an accident; it is therefore not suitable for independent use.

**Table 3 — Exceptional considerations in adaptation of urban areas or at the entrance of existing buildings**

Max. rise, mm	Max. slope	Max. slope, mm/m	Max. length between landings, mm	Exceptional considerations only	Handrails required
1 250	1 in 12 (8,3 %)	83	15 000	yes	see 8.5
1 150	1 in 11 (9,1 %)	91	12 650	yes	see 8.5
1 000	1 in 10 (10,0 %)	100	10 000	yes	see 8.5
750	1 in 9 (11,1 %)	111	6 750	yes	see 8.5
375	1 in 8 (12,5 %)	125	3 000	yes	see 8.5
35	1 in 8 (12,5 %)	125	280	threshold ramps only	no

Ramps with a gradient greater than 1:12 (83 mm/m) should only be used in existing environments under special circumstances decided at a national level.

### 8.3 Width of ramps

- The surface width of a ramp shall be not less than 1 200 mm.
- The unobstructed width of a ramp shall be not less than 1 000 mm between the handrails or any obstructions.

*Exceptional considerations in adaptation of urban areas or at the entrance of existing buildings:* The unobstructed width of a ramp shall be not less than 900 mm.

### 8.4 Landings of ramps

An end landing shall be provided at the foot and the head of a sloped path, a stepped path, or a ramp. The area of an end landing may be a part of the continuing path (see Figure 8).

The length of an end landing and an intermediate landing shall be not less than 1 500 mm.

The length of an intermediate landing at any change in direction of more than 10° shall be at least 1 500 mm measured on the centre line (see Figure 8).

*Exceptional considerations for existing buildings:* The clear space at the beginning and at the end of the ramp shall be at least 1 200 mm at surface level. Intermediate landings shall also be at least 1 200 mm.

The area of a landing shall be clear of any obstruction including the path of swing of a door or gate.

### 8.5 Support and guidance by handrail on ramps

For general requirements of handrails, Clause 14 and the following should be considered:

- a handrail should be provided on each side of a ramp when the length of the ramp is 800 mm or less and there is an alternative stepped access;
- a handrail shall be provided on each side of a ramp if the ramp exceeds 800 mm in length.

The minimum distance between handrails shall be 1 000 mm.

### 8.6 Drainage of ramp

Consider the general requirements in 7.13.

### 8.7 Surface materials

Surface materials shall be rigid with a plain and slip-resistant surface, in both wet and dry conditions.

## 9 Guarding along paths and ramps

Providing protection at the side of the path protects people who use wheelchairs and ambulant people from injuring themselves as the result of a fall. See examples of protection against falling in Figure 9.

- If a level or sloped path is bounded on one or both sides by terrain that slopes downwards by up to 30° from the horizontal, a firm and level margin of at least 600 mm shall be provided at the relevant side or sides.
- If a sloped path or ramp is bounded on one or both sides by terrain that slopes downwards by 30° or more, an upstand of minimum height of 150 mm shall be provided at the relevant side or sides. Upstands shall have a minimum difference in LRV of 30 points in relation to the ramp.

- If a path, or a sloping path, stepped path, ramp, terrace or other unfenced platform rises more than 600 mm above the adjacent ground, it shall be provided with guarding. If the adjacent ground is firm and level with the path for 600 mm, no guard is needed.

Guarding shall be designed to discourage a user, particularly a child, from climbing on it.

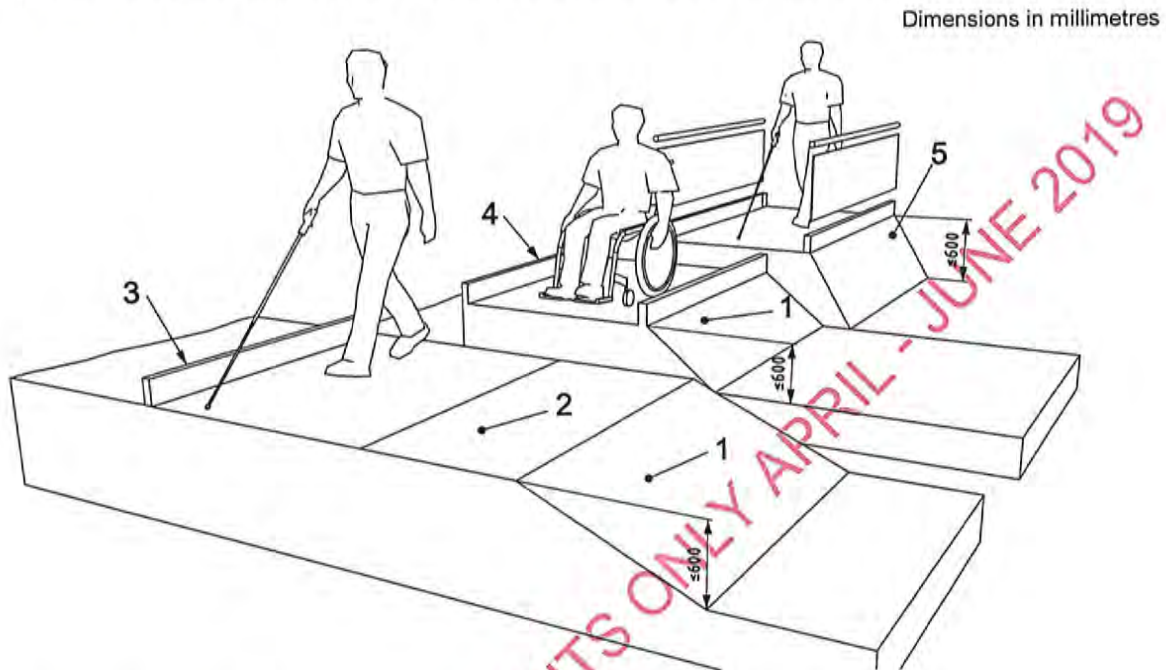

#### Key

- 1 slope less than 1:3 (333 mm/m)
- 2 level margin min. 600 mm wide
- 3 upstand where the difference in level is 600 mm or less
- 4 upstand with a min. difference in LRV of 30 points in relation to the path or ramp
- 5 upstand with guarding where the difference in level is greater than 600 mm

Figure 9 — Examples of protection against falling

## 10 Building entrances and final fire exits

### 10.1 General

The entrance(s), including final fire exits, to a building should be easy to locate, safe and convenient to use and have limited exposure to rain and snow. Entrance doors should be sufficiently high and wide, easy and intuitive to operate (see 18.1).

Information concerning fire safety and fire evacuation procedures should be conveniently located at all entrances and final fire exits. Information on evacuation plans should be available to all building users in a format they can understand. This may include large print, audio, Braille, easy-to-read.

Entrance doors should be capable of resisting the forces of prevailing winds without opening unexpectedly. Conventional swing, sliding or bifold doors shall always be located adjacent to revolving doors for the purposes of unhindered access.

These requirements shall be met at the principal entrance(s) to and exit(s) from the building.

## 10.2 Identification

The principal entrance to a building shall be identifiable from the boundary of the site and from any designated accessible parking spaces on the site. If the entrance cannot be easily identified, suitable means of visual and tactile wayfinding shall be provided.

## 10.3 Floor level at the entrance

Entrances into the building should be level. Any raised threshold shall not exceed 20 mm.

Where a raised threshold is necessary, it shall have maximum height of 20 mm, be bevelled down, and have a minimum difference in LRV of 30 points compared to the floor (see Figure 10).

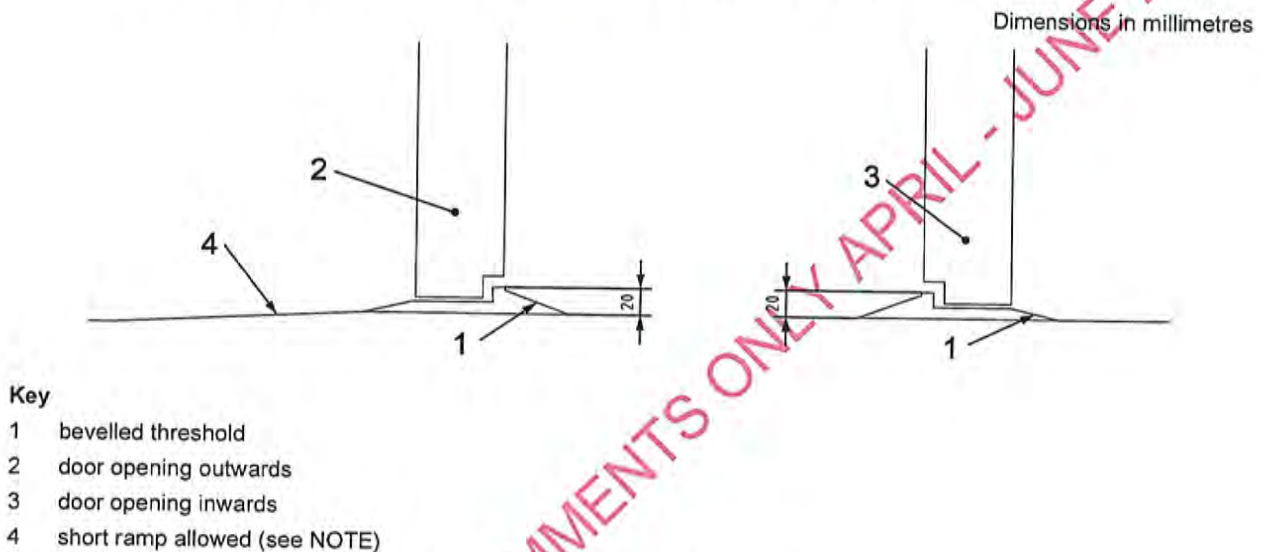

**Figure 10 — Bevelled threshold**

If the level of the entrance storey is above that of the surrounding ground, a suitable sloped or ramped approach and landing shall be provided immediately outside the principal entrance.

**NOTE** At entrance doors, when required for thermal insulation and airtightness, a high degree of overlap between door leaf and threshold may be necessary, resulting in a relatively small clearance between landing and door leaf. For this reason a short ramp of no more than 300 mm in length and a slope of max. 1:12 may be allowed.

Any permanent or temporary feature provided at floor level to limit incoming dirt or water should be set flush with the remainder of the floor or, if surface laid, should be a regularly serviced, washed and exchanged flooring type with rubber banking and chamfered edges which maintain surface adhesiveness and prevent folding or crinkling.

## 10.4 Principal entrance doorway

Detailed requirements for doors are specified in Clause 18.

## 10.5 Doorway width

The minimum unobstructed width of an entrance doorway shall be not less than 800 mm; 850 mm or more is recommended as more space can be required for a person using a powered wheelchair.

**NOTE** Many national building regulations require a minimum width of 900 mm for an entrance door.

## 10.6 Clear height of a doorway

The minimum clear height of a doorway shall be not less than 2 000 mm.

## 10.7 Circulation space

In front of the door opening into the building, there should be a minimum horizontal manoeuvring space of 1 500 mm by 1 500 mm. Where turning 180° in a wheelchair may be required, there shall be a minimum of 1 600 mm by 2 150 mm. A clear space of 600 mm (700 mm recommended) at the latch side of the door is required to allow someone to operate the door handle (see Figure 11).

For alternative openings and constructions, see Annex C.

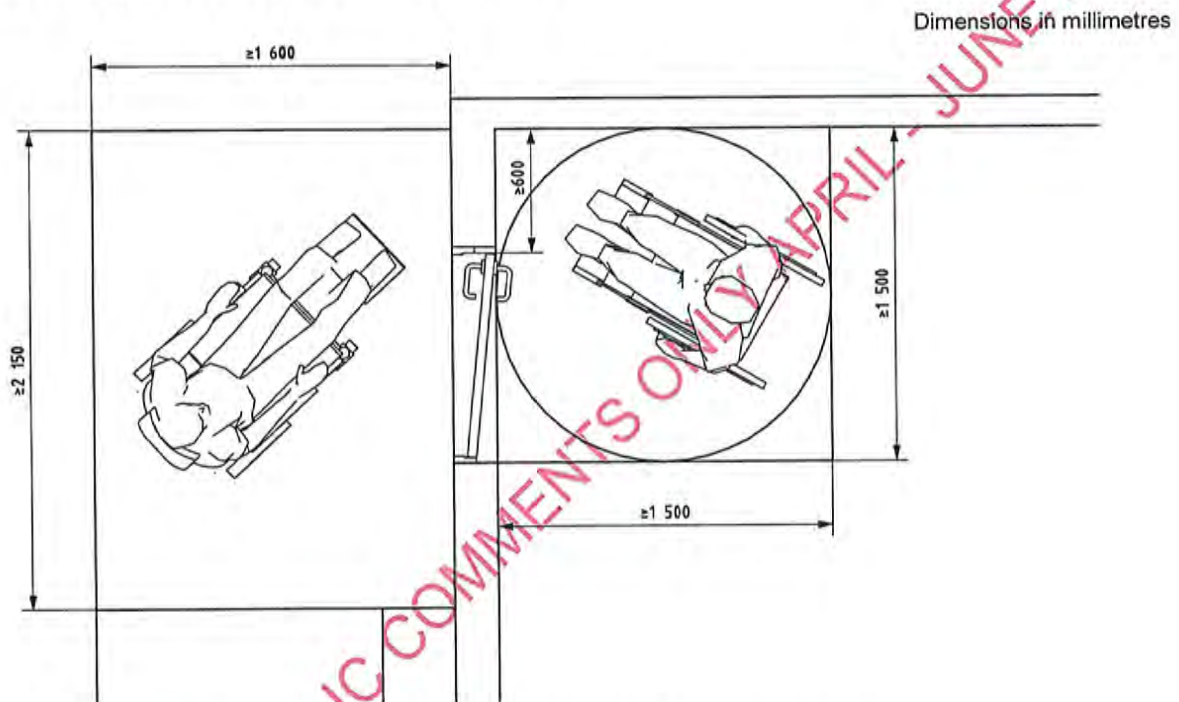

Figure 11 — Circulation space at a swinging door

## 10.8 Lobbies

### 10.8.1 General

Lobbies shall allow people to enter the built environment without any hindrance or barriers. See 18.1 for the design of doors.

### 10.8.2 Unobstructed manoeuvring space

The minimum unobstructed manoeuvring space between doors in an entrance lobby shall be not less than 1 500 mm free of the door swing (see Figure 12).

In single swing doors, in the lobby, the door should swing outwards.



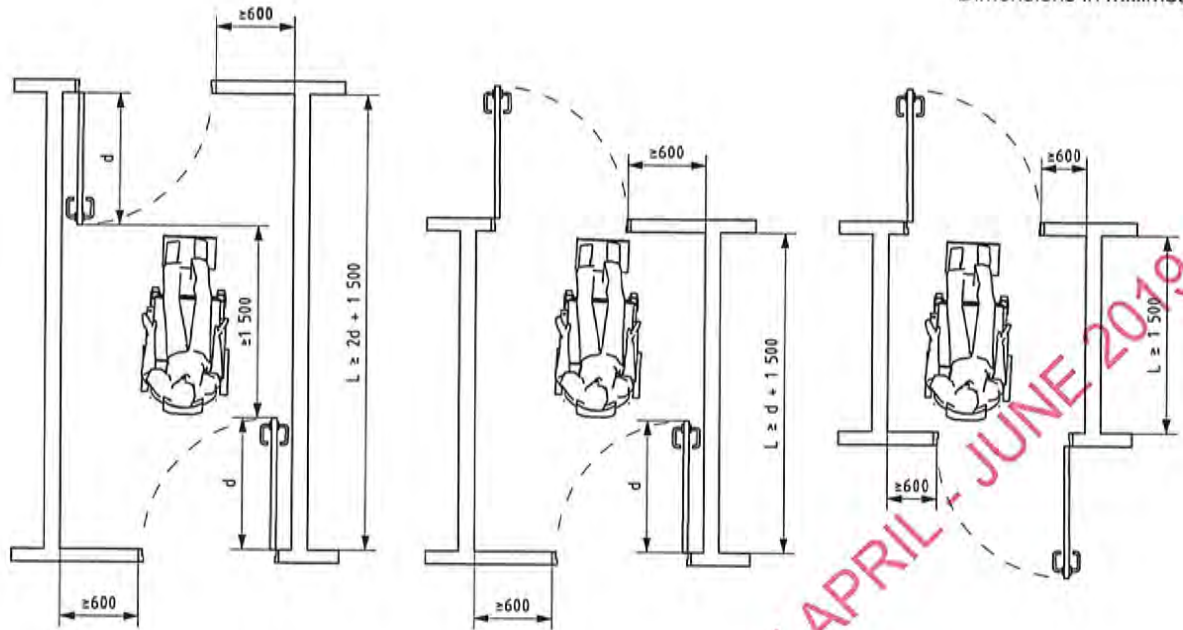

Figure 12 — Minimum dimensions of lobbies with single leaf single swing doors

### 10.9 Visibility through an entrance door

Except when necessary to maintain security or privacy, an entrance door shall be designed to permit visual awareness of the layout of the building immediately beyond.

The requirements for viewing panels in 18.1.6 and for visual contrast in 18.1.7 should also be considered.

## 11 Horizontal circulation

### 11.1 General

The main horizontal circulation design shall be level on each storey in order to ensure that the building is accessible to all people. Horizontal circulation shall be without steps. Where differences in level cannot be avoided, ramps or lifts shall be provided (see Clauses 8, 15 and 16).

Buildings should be designed, constructed and managed so that the internal layout is accessible and easily understood. All aspects of horizontal circulation, including corridors, should be designed to facilitate ease of movement for all people.

In order to avoid a tripping hazard (especially during a fire evacuation), where a raised threshold is necessary at a door opening, its maximum height shall be 20 mm, it shall be bevelled, and shall have a minimum difference in LRV of 30 points compared to the floor.

Routes should preferably intersect at right angles to each other and be easy to follow. To facilitate people with visual impairments, routes should have detectable delimitations and different visual contrast from the surroundings. For orientation and wayfinding in very complex buildings and across large areas, guidance can be provided by tactile walking surface indicators and visual, audible and tactile information, including egress and evacuation (see Clause 39).

**NOTE** Handrails can provide support for people with impaired mobility, guidance for people who are blind or have impaired vision, and can also support Braille information or tactile information.

## 11.2 Internal passages

The minimum unobstructed width of corridors shall be 1 200 mm, with a preference for a width of 1 800 mm.

Where less than 1 800 mm wide, a corridor shall be provided with passing places, 1 800 mm wide and at least 1 800 mm in length at reasonable intervals. These dimensions shall be exclusive of handrails and any other projections, e.g. portable fire extinguishers, notice boards, coat hooks, etc.

*Exceptional considerations for existing buildings in developing countries:* In some member states where shorter and smaller wheelchairs are generally used and due to market situations, the internal passages may be reduced to a width of 900 mm for short straight passages of maximum 2 000 mm length. Wherever possible this internal passage width should be increased to 1 200 mm.

Adequate circulation space, where a doorway exists, shall be provided. Annex C gives advice on the provision of circulation space on each side of a doorway.

Intensity in use of the corridor shall be a criterion when establishing the minimum width and length of the corridor (see Figure 13).

**NOTE** In some countries, the width of passage used for escape is defined by other criteria (e.g. number of people, surface of premises); see also Annex D.

Changes of direction within a corridor shall have a turning circle with a diameter of 1 500 mm or more, clear of any obstructions (see Figure 14).

The minimum clear height of corridors shall be 2 100 mm.

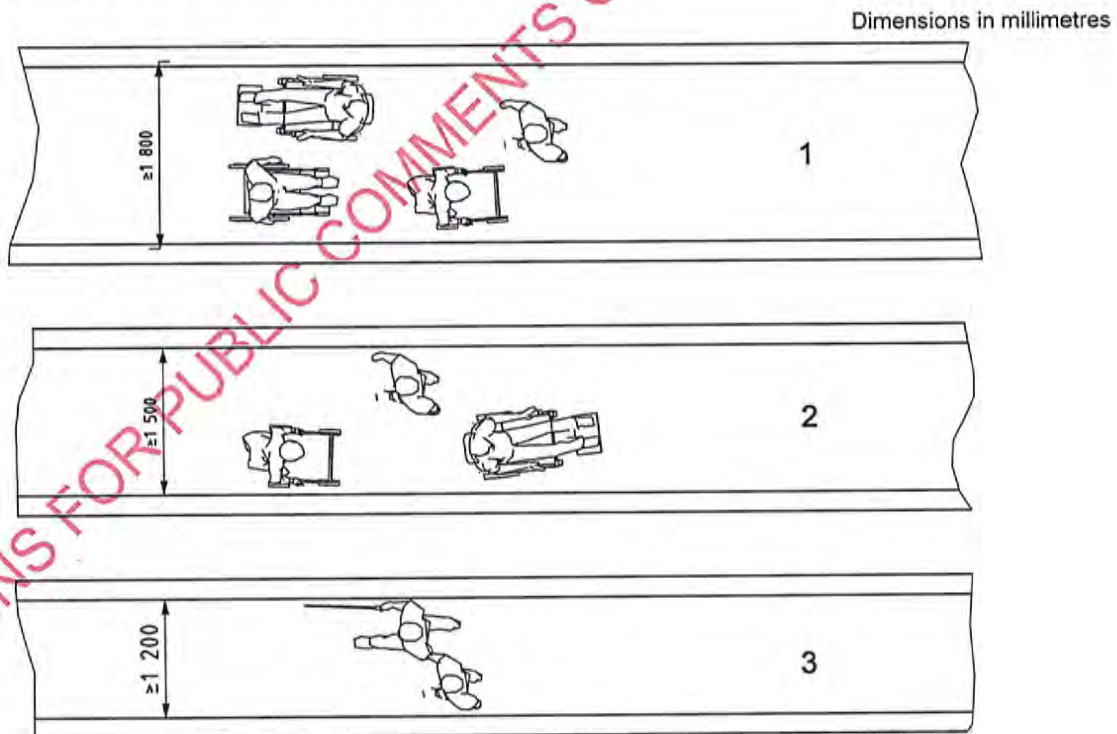

### Key

- 1 constant two-way traffic
- 2 frequent two-way traffic
- 3 infrequent two-way traffic

Figure 13 — Different corridor widths determined by intensity of use

Hanging objects on walls should be avoided, except when they comply with 7.14. The minimum unobstructed width shall remain 900 mm.

### 11.3 Turning space for 90° turn of a wheelchair in corridors

The manoeuvring zone required for a wheelchair to make a 90° turn shall be designed according to Figure 14.

It shall have no gradient, and it shall not be less than 1 200 mm wide and 1 200 mm long in the direction of travel.

*Exceptional considerations for existing buildings in developing countries:* In some member states where shorter and smaller wheelchairs are generally used and due to market situations, the manoeuvring zone required for a wheelchair to make a 90° turn may be reduced to a width of 1 000 mm and a length of 1 000 mm in the direction of travel.

If one corridor has a dead end, the solution in Figure 15 should be considered.

A corridor 1 500 mm long in the direction of travel is recommended for ease of turning.

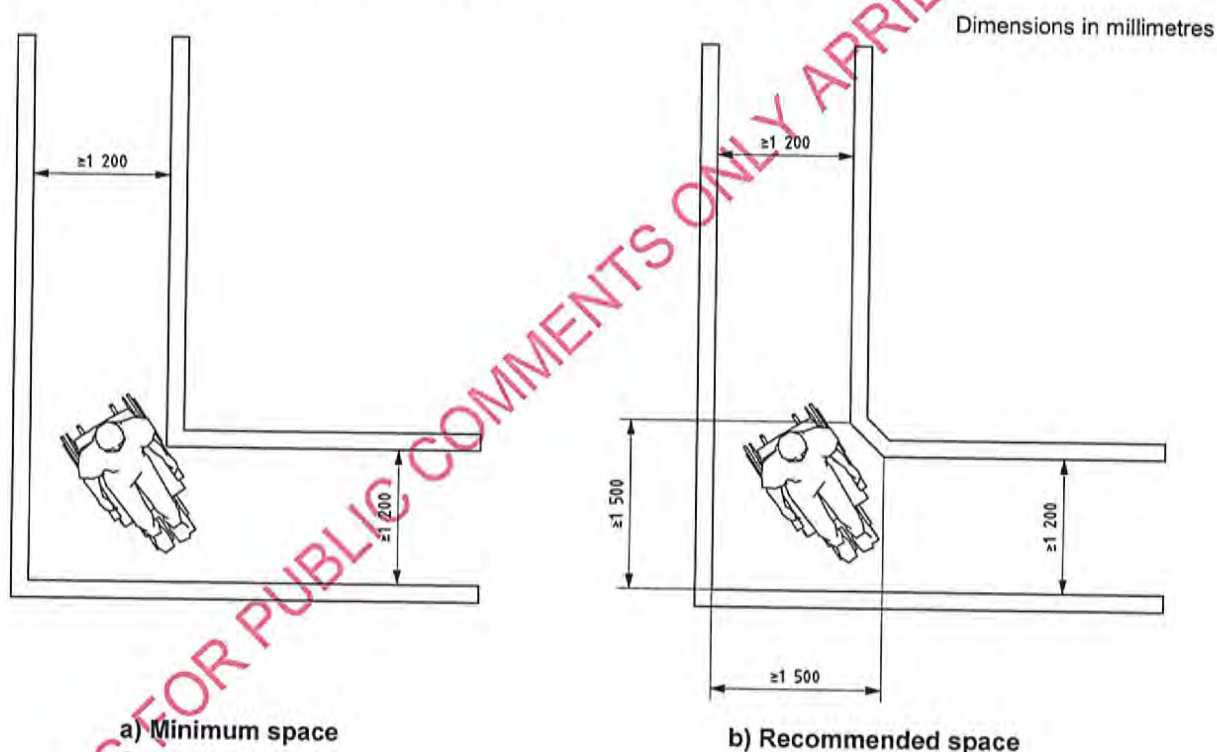

Figure 14 — Minimum and recommended space required for a 90° turn

### 11.4 Circulation space for 180° wheelchair turn

The space required for a wheelchair to make a 180° turn shall be not less than 2 000 mm in the direction of travel and not less than 1 500 mm wide (see Figure 15).

*Exceptional considerations for existing buildings in developing countries:* In some member states where shorter and smaller wheelchairs are generally used and due to market situations, the width of the space required for a wheelchair to make a 180° turn may be reduced to 1 200 mm.

For landing dimensions, see 13.3.

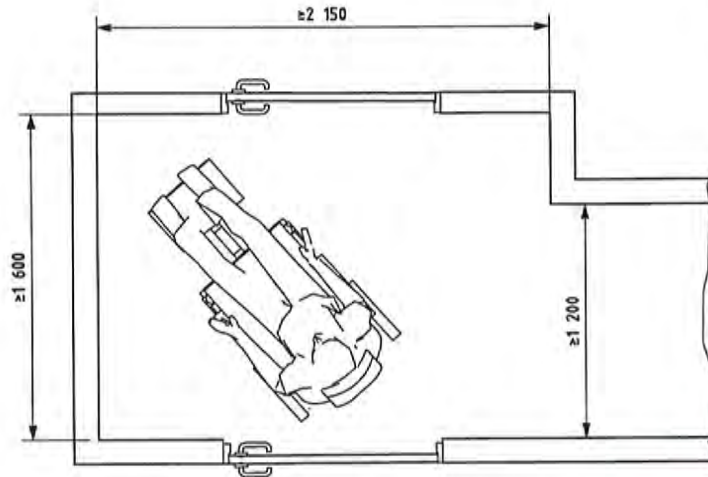

Figure 15 — Space required for a 180° turn in a corridor

## 12 Vertical circulation

### 12.1 General

Vertical circulation within buildings should be designed, constructed and managed so that it can easily be understood and used by people. Vertical circulation includes the provision of stairs, lifts and ramps, as well as escalators, travelators and lifting platforms.

### 12.2 Ramps in buildings

General requirements for ramps are set out in Clause 8. Internal ramps should, if possible, be avoided. Where required, internal ramps shall be designed in accordance with the following additional criteria:

- no series of ramps should rise more than 2 000 mm in total. If this is the case, an alternative should be provided, e.g. a lift;
- in order to avoid trips and falls during a fire evacuation, a gradient of 1:15 (67 mm/m, 6,7%) should be the maximum permissible gradient within a building.

An internal ramp should have the lowest practical gradient.

The minimum illumination at the top and bottom of the ramp should be 200 lux and 150 lux in between the bottom and top. See lighting requirements in Clause 33.

## 13 Stairs

### 13.1 Rise and going of steps

The rise and tread of steps within flights shall be uniform.

For the purpose of safe assisted fire evacuation of people, the rise of a step should not have a height greater than 150 mm, and the going of a step should be not less than 300 mm. The minimum going of the tread shall be 260 mm, and the maximum rise shall be 180 mm. Due to safety reasons and anthropometric differences, it may be recommended to increase the minimum depth of the going.

Spiral and curved stairs are not recommended. Should spiral and curved stairs be used, the inside handrail should have the inside edge vertically parallel with the going at a point where the depth of the going is a minimum of 220 mm.

The sum of the going and twice the rise of a step should be not less than 600 mm and not more than 660 mm.

The riser of a step shall not be open.

The projection of a step nosing over the tread below shall be avoided but, if necessary, shall not be more than 25 mm. The nosing shall provide an uninterrupted transmission between riser and tread (see Figure 16).

A flight of steps should not contain more than 16 risers. However, in circumstances where the plan area is restricted, a flight of a stairs shall contain no more than 20 risers.

The minimum illumination at the top and bottom of the flight should be 200 lux and 150 lux in between. See lighting requirements in Clause 33.

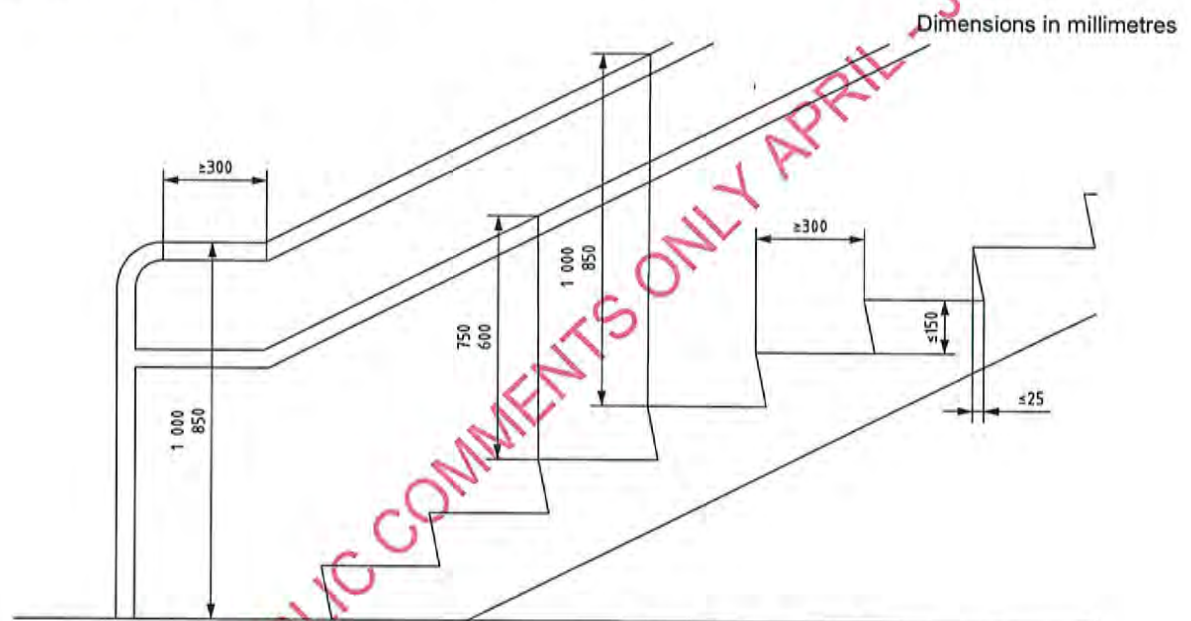

Figure 16 — Recommended going and rise of steps

### 13.2 Minimum width of stair flights

The minimum width of a flight of stairs shall be 1 200 mm.

The minimum width between handrails shall be 1 000 mm.

*Exceptional considerations for existing buildings in developing countries:* In some member states, the minimum width of a flight of stairs may be reduced to 900 mm and the minimum width between handrails may be reduced to 800 mm.

To allow sufficient space for an evacuation chair to travel downstairs, while providing space for the purpose of accommodating contraflow, i.e. emergency access by firefighters rescue teams entering a building and towards a fire, while people are still evacuating from the building, the clear unobstructed width, exclusive of handrails and any other projections, e.g. portable fire extinguishers, notice boards, etc., of the flight of single- or multi-channelled stairs should be not less than 1 500 mm. The surface width of a flight of stairs should not be less than 1 700 mm.

### 13.3 Staircase landings

The area of a landing shall be clear of any obstruction including the path of the swing of a door or gate. Where there is a half landing or a 180° turn, it shall never be less than 1 500 mm wide in order to facilitate carrying a person on a stretcher. See Figure 17.

If the stepped path is multi-channelled, the length of an intermediate landing shall not be less than the unobstructed width of the widest channel.

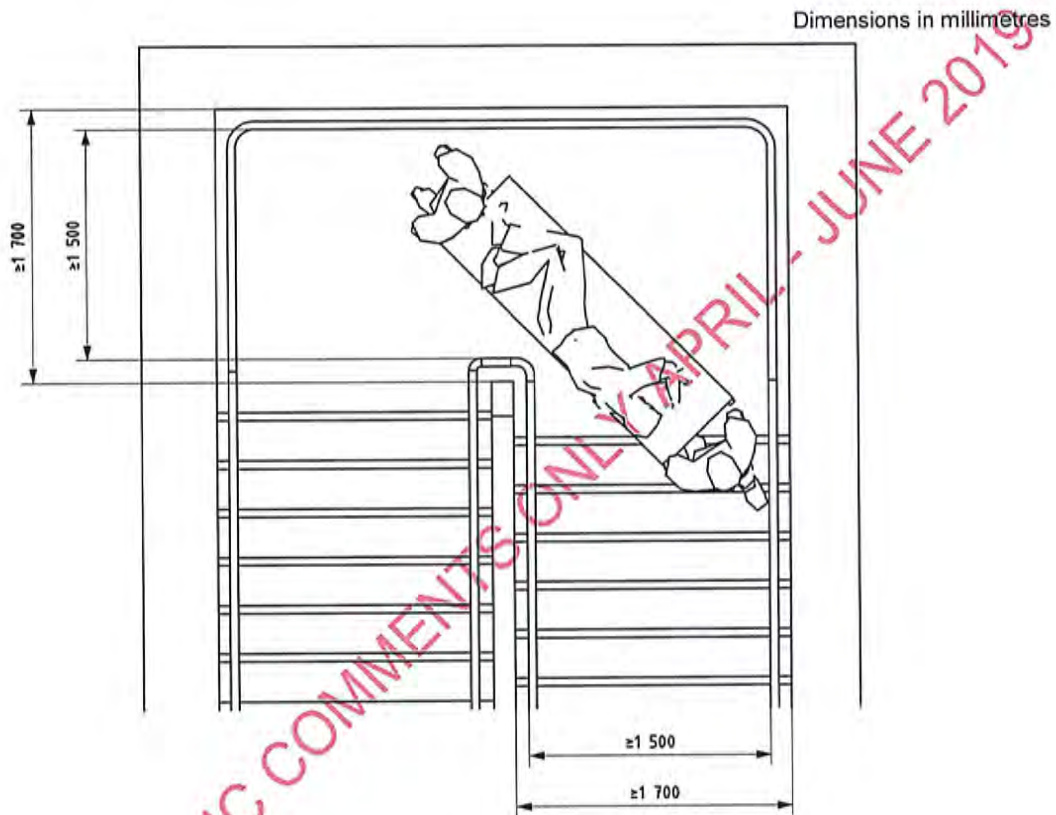
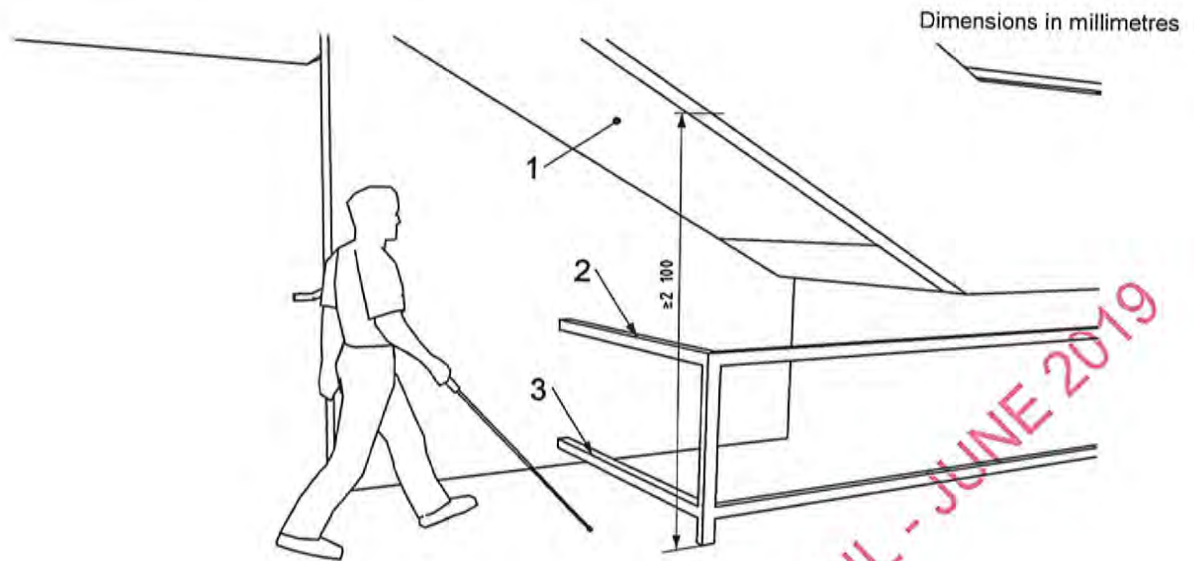

Figure 17 — Example of stair and 180° landing for emergency access

### 13.4 Head clearance

Clear accessible height under stairs shall be a minimum of 2 100 mm or greater. If the clear height is less than 2 100 mm, a guard or other element shall be provided to shield against impact. See Figure 18.

Head clearance on the stair shall be minimum 2 100 mm.



**Key**

- 1 min. 2 100 mm clear height
- 2 guard against impact
- 3 guard detectable with cane, max. 300 mm above floor

**Figure 18 — Clear height under stairs**

### 13.5 Visual and tactile warnings

There shall be a visual contrast (see 35.1) between landings and the top and bottom step of a flight of stairs. Preferably, a visual warning line with a single strip of 40 mm to 50 mm without a break shall be provided on the front edge of the going of each step with a minimum difference in LRV of 60 points and may return down the riser for a maximum of 10 mm. The visual indicator on the going may be set back a maximum of 15 mm from the front of the nosing. As an alternative solution, a visual warning line with a width between 50 mm and 100 mm shall be provided on the going of the first and the last step of the flight. See Figure 19.

Where a stair is in an open area, a tactile attention pattern may be beneficial. National regulations can require the systematic use of tactile warning on any stair. However, where different materials are used for the flights and landings of a stair, care should be taken to ensure that their frictional characteristics are similar in order to minimize the risk of stumbling.

Where tactile attention patterns are used, they should be provided on the landings at the top and bottom of every flight of stairs across the whole width of the stair. The tactile attention pattern should have a depth of between 600 mm and 900 mm ending 300 mm to 500 mm before the front edge of the first down going step. For dimensions of attention patterns see Figure 19 and Annex A.

Where tactile attention patterns are used at the top and bottom of stairs, the attention pattern shall not reduce visual detection of the first and the last step of the flight.

### 13.6 Guards along stairs

If a stair rises more than 600 mm above the adjacent ground, it shall be provided with guards from that point on (see Clause 9).

Dimensions in millimetres

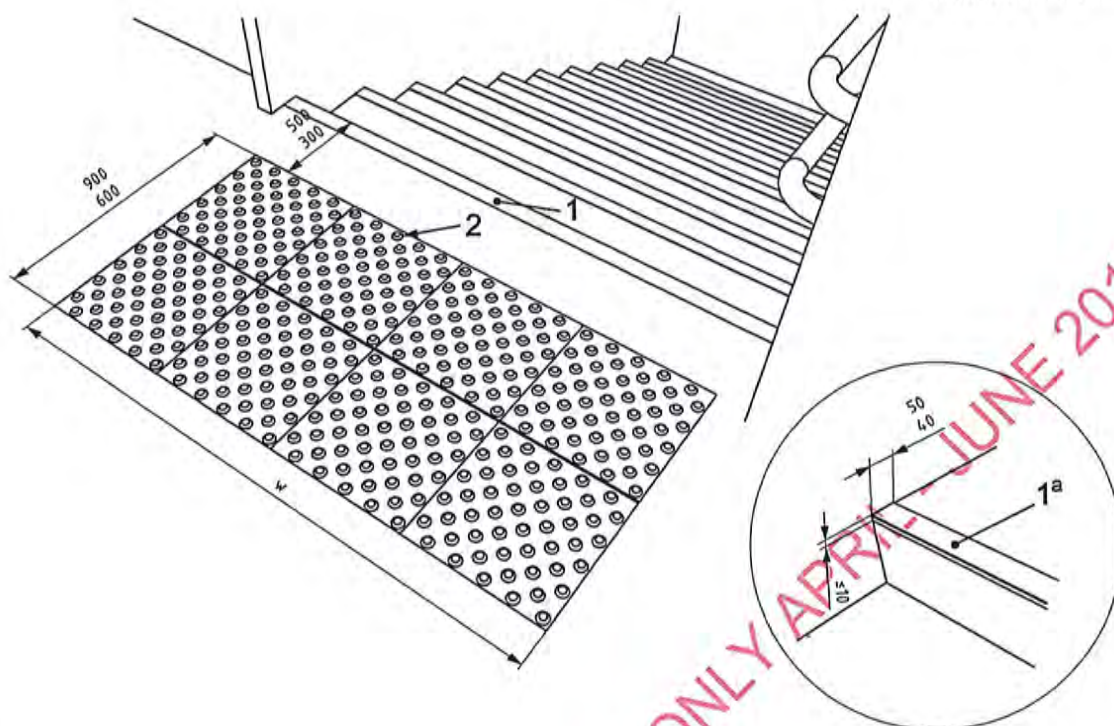

#### Key

- 1 visual warning line
- 2 tactile warning surface indicator with max. height of pattern 5 mm
- w full width of stairs
- <sup>a</sup> Preferred option. Not a requirement.

Figure 19 — Tactile walking surface indicator (TWSI) and visual indicator

## 14 Handrails

### 14.1 General

A handrail provides a means of support, stability and guidance for the user. A handrail will help most people to go up or down a flight of steps or a ramp. However, a handrail also provides an essential means of support, stability and guidance for all building users during a fire evacuation.

Handrails shall be provided for stepped and sloped paths, ramps and stairs and lift cars according to the requirements given in 14.2 – 14.8.

### 14.2 Provision of handrails

A handrail shall be provided on both sides of all flights of stairs, and a central handrail should be provided when the unobstructed width of the stairs exceeds 2 700 mm, provided that an unobstructed width of at least 1 500 mm is provided on one side.

*Exceptional considerations for existing buildings:* a handrail should be provided on at least one side of the flight of stairs (principal difficulties arise in relation to heritage buildings).



### 14.3 Profile of a handrail

A handrail shall:

- have a rounded profile that can be inscribed into a 45 mm circle, and subscribed to a 35 mm diameter circle. The radius of the rounded edges shall be minimum 15 mm;
- be located to provide a minimum clear space of 40 mm from an adjacent wall or other obstruction;
- have an overall projection from any side obstruction of not more than 100 mm;
- have the top 270° arc of the handrail clear along its full length;
- have a minimum of 50 mm clearance under the 270° arc along the full length of the handrail for finger indentation;
- have a surface that is smooth but provides adequate resistance to hand slippage.

**NOTE** A wide and relatively flat-topped surface on a handrail provides better support than a regularly curved one. Graspability is better on a handrail that does not require significant hand and finger joint movement. For these reasons, the use of a handrail that is elliptical is preferred.

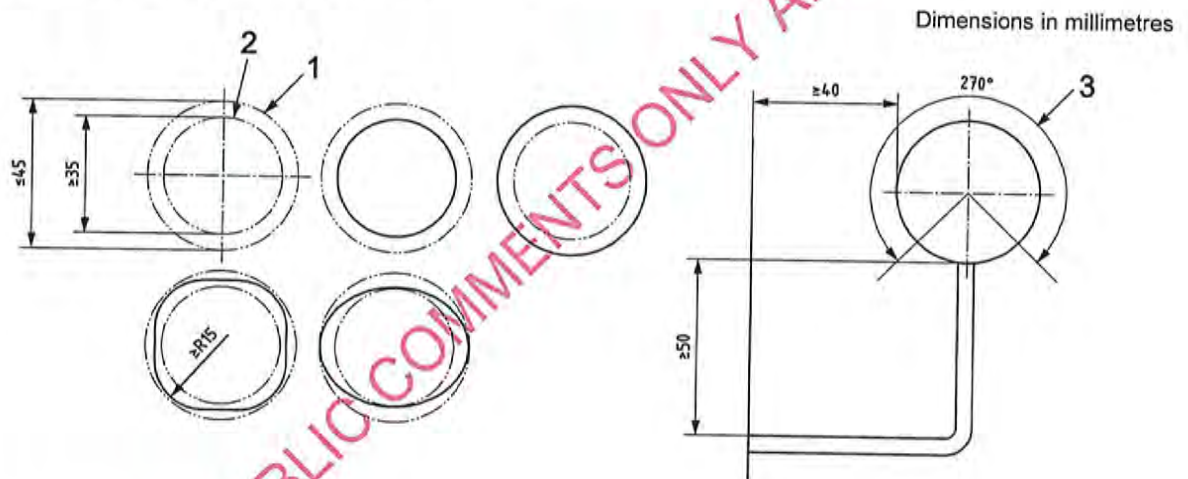

#### Key

- maximum inscribed circle for handrail profile
- minimum subscribed circle for profile
- minimum 50 mm clearance under top 270° arc along full length of handrail

Figure 20 — Examples of handrail profiles, support and clearance

### 14.4 Continuity of a handrail

Handrails should be continuous throughout the flight of a ramp, stair, stepped path and intermediate landing, except where they intercept with a doorway or path of travel.

### 14.5 Height of a handrail

The height to the top of a handrail shall be between 850 mm and 1 000 mm above the surface of a ramp, the pitch line of a stair, and the surface of a landing.

A second handrail, with a lower profile than the first one, shall be provided. The height to the top of the second handrail should be between 600 mm and 750 mm above the surface of a ramp, the pitch line of a stair, and the surface of a landing.

#### 14.6 Horizontal extension of a handrail

A handrail on a stepped path, stair or ramp shall have a horizontal extension of not less than 300 mm beyond the first and last nosing of each flight.

A handrail shall not project into a transverse circulation path unless it is continuous and intended to form part of the guidance along that path.

The end of the horizontal extension should be turned towards the wall on the closed side of the ramp or stairs, or be turned down and terminate at the floor or ground level.

NOTE This provision supports people with mobility impairment and limits the risk of clothing being caught.

#### 14.7 Visual and tactile information

The minimum visual contrast of a handrail to the adjacent background, e.g. a wall, shall comply with the requirements outlined in Clause 35.

Raised text or tactile symbols shall be unobtrusively and permanently fitted or fixed to handrails as an important source of information for people who have a vision impairment, e.g. indication of floor number, direction of fire evacuation, location of final fire exits, etc.

Visual and tactile information should be provided according to 7.2, and Clauses 33, 35, 39 and 40.

#### 14.8 Mechanical resistance

Handrails shall be securely fixed and rigid. The fastenings and the materials shall be able to withstand a minimum point load, both vertical and horizontal, of 1,7 kN.

### 15 Lifts (Elevators)

#### 15.1 General comments

All accessible levels of a building shall be accessible with ramps or lifts (elevators). Lifts are preferable, and shall be accessible for all people, including people with disabilities. The minimum inner dimensions of cars are given in 15.2.

NOTE 1 Requirements for the minimum size and numbers of lift cars are a matter of national building regulations.

Where national regulations do not require a lift in a multi-storey building, a space for an accessible lift with a minimum internal lift car size of 1 100 mm × 1 400 mm of 630 kg should be provided for later adaptation.

The method of measurement of the internal lift car size may vary from one country to another (see ISO 4190-1).

*Exceptional considerations for existing buildings in developing countries:* In some member states where shorter and smaller wheelchairs are generally used and due to market situations, the space for an accessible lift provided for later adaptation may be reduced to the one for an accessible lift with a minimum car size of 1 000 mm × 1 250 mm.

NOTE 2 Only people with small wheelchairs without any accompanying person can use such a small lift. People with powered wheelchairs and persons with walking aids will not have enough manoeuvring space therein.

Requirements concerning the size of accessible lifts are stated in ISO 4190-1 as lifts “accessible for wheelchairs”.

The requirements of ISO 4190-1 give dimensions for a wide range of accessible lifts for persons in different lift classes:

- Class I, General purpose lifts,
- Class III, Health care lifts, including hospitals and nursing homes,
- Class VI, Intensive use lifts for high-rise buildings.

All technical requirements for accessible lifts shall comply with ISO 4190-1.

All control devices, signals and additional fittings shall comply with ISO 4190-5, except when different requirements are specified in Clause 15, especially when particular requirements for easy access for disabled persons are mentioned.

NOTE 3 The relevant standard for lifts used by persons including persons with disabilities within CEN Member States is EN 81-70, developed by CEN/TC 10 “Lifts, escalators and moving walks”. CEN/TS 81-82 was developed for the improvement of accessibility of existing lifts. Several European standards of CEN/TC 10 are also applied overseas, e.g. in China, Japan, etc. There is a close cooperation between ISO/TC 178 and CEN/TC 10.

## 15.2 Inner dimensions of cars

The following accessibility requirements shall apply.

Inner dimensions of cars shall be according to ISO 4190-1:2010, and shall be marked with Figures 66 or 71, showing that they fulfil minimum accessibility requirements.

The minimum inner dimensions of cars which are accessible for a wheelchair user and an accompanying person are 1 100 mm × 1 400 mm. A minimum unobstructed entrance width of 800 mm shall be provided on the narrow side of the car. The recommended unobstructed entrance width is 900 mm (see Figure 21). See also ISO 4190-1:2010, Figure 6, Class I – General-purpose lifts, 630 kg.

If a trolley with a stretcher is considered, the minimum inner dimensions of cars shall be 1 200 mm × 2 300 mm. A minimum unobstructed entrance width of 1 100 mm shall be provided on the narrow side of the car (see Figure 21). Consider ISO 4190-1:2010, Figure 8, Class III – Health-care lifts, 1 275 kg.

NOTE 1 ISO 4190-1:2010, Figure 8 describes many additional accessible lift cars, e.g. to facilitate transporting a stretcher or bed. They are clearly marked with the wheelchair or bed symbol. All these accessible lifts allow full manoeuvrability for people with wheelchair and walking aids.

If an entrance is provided on two adjacent sides, the minimum inner dimensions of cars shall be 1 600 mm × 1 400 mm, with a 900 mm unobstructed door width (see Figure 21).

NOTE 2 ISO 4190-1 does not cover adjacent doors on lift cars.

Dimensions in millimetres

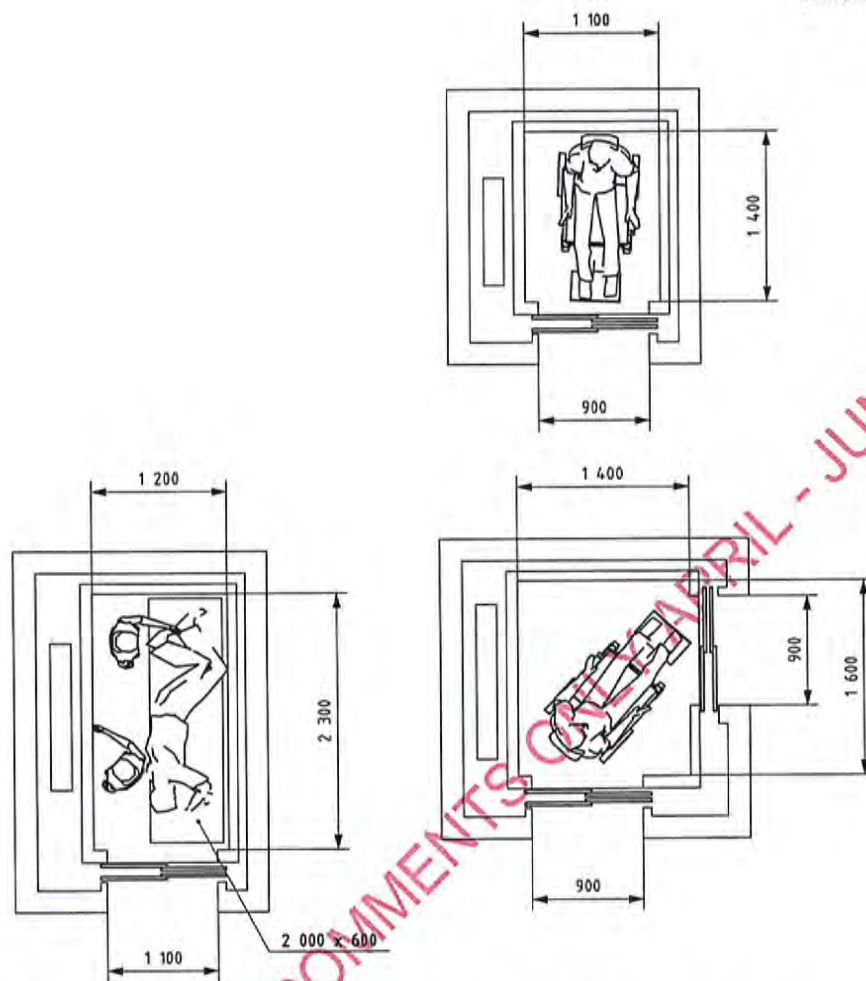

Figure 21 — Examples of lifts accommodating one person in a wheelchair, a person on a stretcher and a person performing a 90° turn between two adjacent lift doors

### 15.3 Lift car entrance — Door opening

Accessibility of the landing is required on all eligible floors.

The unobstructed entrance width shall be at least 800 mm; 900 mm is preferred. See 15.2 for specific situations that require a broader unobstructed entrance width.

National regulations may require more than 800 mm (see Introduction).

The car and landing doors shall be constructed as automatic power operated horizontally sliding doors.

The colour and tone of the lift entrances should contrast with the surrounding wall finishes (see Clause 35).

The door opening time shall be adjustable to suit the conditions where the lift is installed (normally between 2 s and 20 s). A mechanism to increase this time shall be installed to be customized by a user with mobility impairments (e.g. by means of a button outside the car to call the lift to the floor for it to arrive with extended door opening time, and a button marked with a wheelchair symbol inside the car with the same purpose).

A presence sensor device shall cover the opening over the distance between at least 25 mm and 1 800 mm above the car door sill (e.g. light curtain). The device shall be a sensor which minimizes the likelihood of physical contact between the user and the leading edges of the closing panel(s).

Sufficient manoeuvring space outside the lift entrance shall be provided according to 19.3 and B.6.1 (see Figure 15). The manoeuvring space should not be in any circulation route nor directly opposite to any stair circulation. If a stair is situated opposite the entrance, the distance to the stair shall be at least 2 000 mm to allow safe manoeuvring (see Figure 22). The manoeuvring area shall be adequately lit with a minimum illumination of 100 lux.

*Exceptional considerations for existing buildings in developing countries:* A manoeuvring space of 1 200 mm × 1 200 mm can be accepted according to national regulations and national standards, but could lead wheelchair users to dangerous situations.

NOTE ISO 4190-5 defines the button requirements and its need for contrast, related with the level of lighting provided on the landing.

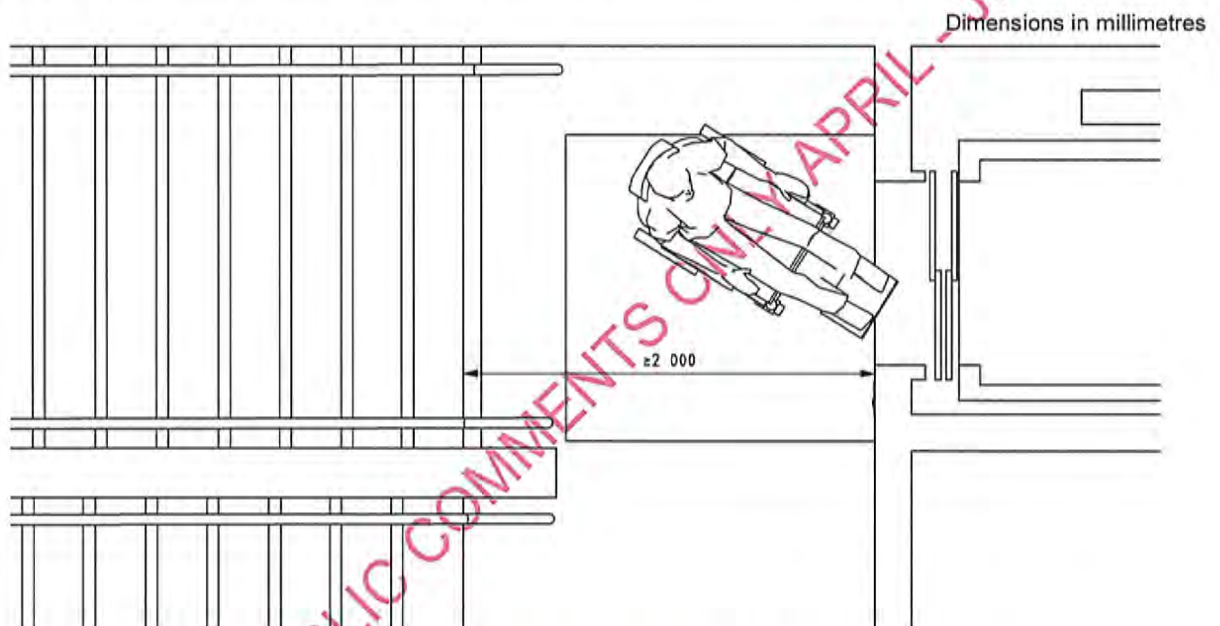

Figure 22 — Manoeuvring space outside the car door opposite a stair

In order to aid in location of the lift entrance, a distinguishable floor surface of approximately 1 500 mm × 1 500 mm should be installed outside the doors. This could be obtained by means of a change of colour or floor finish. Changes in floor finish should be flush.

## 15.4 Equipment in the car

### 15.4.1 Handrail

At least one handrail shall be provided in the car and shall be fixed horizontally on the same side as the car operating panel; it is recommended to provide one handrail on each car wall. Handrails may be interrupted at the car operating panel(s) if it is required to gain access to lift controls. Handrails shall comply with the requirements given in ISO 4190-5:2006, B.5.

The gripping part of the handrail shall:

- be in a perimeter of between 100 mm and 160 mm,
- have a minimum dimension of 25 mm (35 mm is recommended),
- have a maximum dimension of 55 mm (45 mm is recommended), and
- have no sharp edges.

The height to the top of the handrail shall be between 800 mm and 950 mm above the floor; a height of 850 mm  $\pm$  25 mm is recommended.

The free space between the wall and the gripping part shall be between 35 mm and 45 mm; 50 mm is recommended. The handrail shall be interrupted where the car operating panel is located on the same wall, in order to avoid obstructing buttons or controls.

The projecting ends of the handrails shall be closed and turned towards the wall to minimize the risk of injury.

#### 15.4.2 Seat

Where a fold-up seat is provided, it shall have:

- a top height from the floor of (500  $\pm$  20) mm;
- a depth of 300 - 400 mm;
- a width of 400 - 500 mm;
- an ability to support a minimum load of 100 kg; 200 kg is recommended, considering the increasing number of obese people in the worldwide population.

#### 15.4.3 Mirror or mirrored wall within the car

In case of a car size of 1 100 mm  $\times$  1 400 mm where a wheelchair user cannot turn around, a device (e.g. a small mirror) shall be installed to enable the user to observe obstacles behind when moving backwards out of the car. If a glass mirror is used it shall be made of safety glass.

If any wall of the car is substantially mirrored or covered with a reflective surface, measures shall be taken to avoid creating optical confusion (e.g. by means of decorated glass, or a minimum vertical distance of 300 mm between the floor and the bottom edge of the mirror, etc.).

#### 15.4.4 Floor and wall surfaces of the car

Internal walls shall have a non-reflective, matte finish in a colour and tone contrasting with the floor.

The car floor shall be rigid, slip-resistant and have a non-reflective, matte finish.

**NOTE** A lift floor with a high LVR reassures blind and partially sighted people that they are not stepping into an open lift shaft.

The floor of the car should have a similar surface characteristic to the landing floor. The control buttons shall comply with ISO 4190-5 with tactile and contrasting design to the surrounding wall in order to locate them easily.

#### 15.4.5 Allergic materials

Surface materials that a user can be allergic to include nickel, chromium, cobalt and natural or synthetic rubber; these materials should be avoided in buttons, controls, handles or handrails (see Annex B).

#### 15.4.6 Lighting

Internal car lighting should provide a minimum level of illumination of 100 lux at floor level, uniformly distributed, and avoiding the use of spotlights.

#### 15.4.7 Emergency warnings

Emergency warnings shall comply with the requirements of ISO 4190-5.

The car shall have an alarm device (two-way communication system) permanently connected to a manned security point according to the following:

- a) The device shall ensure voice communication in both directions with an organization in charge of passenger rescue or with the person in charge of the safety of the building.
- b) A minimum operating force of 2,5 N shall be required to operate the alarm.
- c) The device shall provide visual and audible information feedback for passengers confirming that:
  - the alarm has been sent, using a yellow enlightened bell-shaped symbol, and
  - the alarm has been received, voice communication established, using the green enlightened symbol consisting of two heads as defined in ISO 4190-5:2006, Table C.1, item 8, "Communication established" indicator.

#### 15.4.8 Stopping/Levelling accuracy

The stopping accuracy of the car shall be  $\pm 10$  mm and a levelling accuracy of  $\pm 20$  mm shall be maintained.

### 15.5 Control devices and signals

Landing and car control devices and signals applicable to a nominal load  $\geq 630$  kg for passenger lifts or higher shall comply with ISO 4190-5 especially those recommended for ensuring the ease of use and access for disabled persons which are specified in ISO 4190-5:2006, Annexes A, B and C.

Where it is intended to provide accessibility for all, controls should be placed within a defined area. Landing controls should be placed at a minimum distance of 500 mm (600 mm recommended) from any adjacent corner or wall. Car controls should be placed at a minimum distance of 400 mm (500 mm recommended) from any adjacent corner or wall. Both landing controls and car controls should be placed between 900 mm and 1 200 mm above floor level, preferably 1 100 mm. The controls can be placed either vertically or horizontally within this area.

**NOTE** In buildings with a small number of floors and a high number of wheelchair users, placing the controls horizontally can be helpful.

If keypad systems and destination oriented lifts are provided they shall be designed according ISO 4190-5:2006, Annex D. People with mental impairments may have difficulties using a keypad system.

In buildings with a small number of floors, it is recommended to use 25 mm  $\times$  25 mm square buttons or 30 mm circular buttons with raised tactile letters, whether they are placed vertically or horizontally.

Braille can be used as a complementary and independent feature to tactile figures and is useful where large texts are necessary.

Dimensions in millimetres

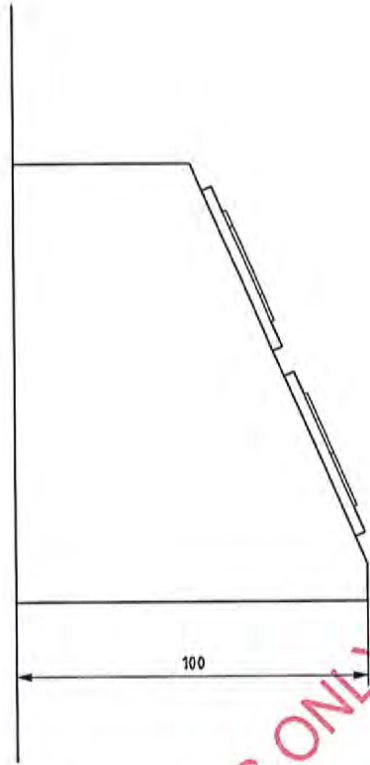
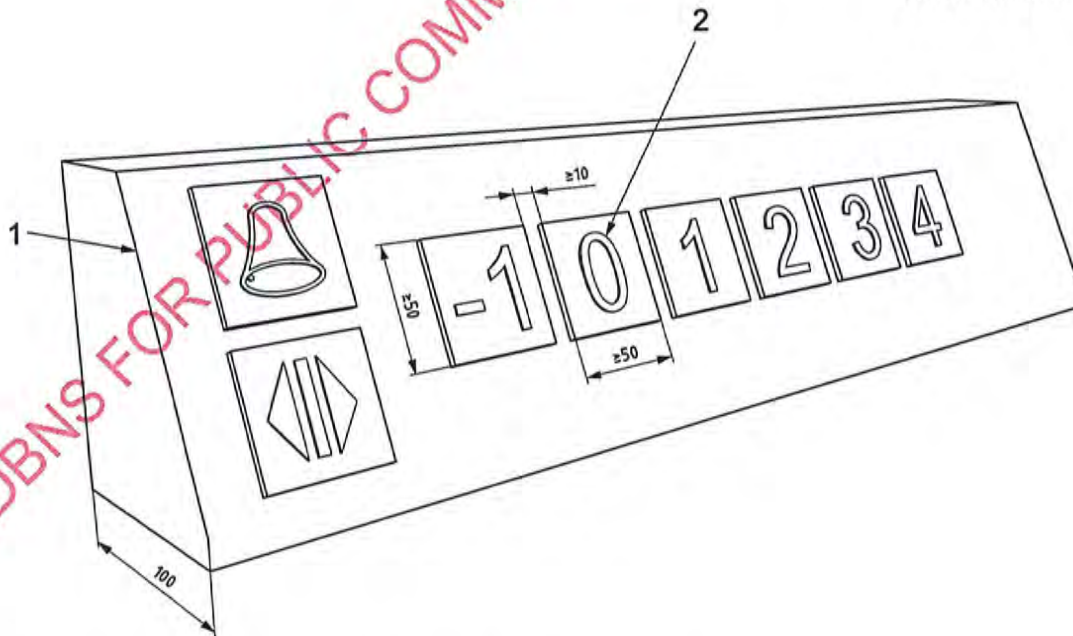

Figure 23 — Horizontal car controls, XL type — Side view, example (ISO 4190-5:2006)

Dimensions in millimetres



**Key**

- 1 single row arrangement on inclined surface
- 2 square 50 mm × 50 mm or round push button with raised tactile letters

Figure 24 — Example of arrangement of a single row of square or round push buttons

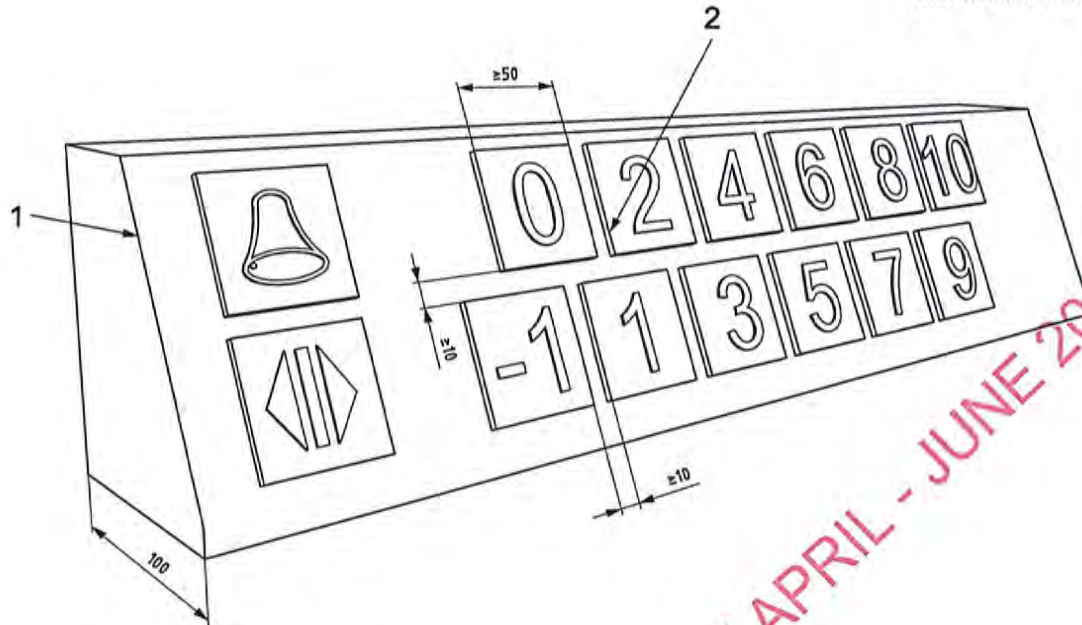

**Key**

- 1 two row arrangement on inclined surface
- 2 square 50 mm × 50 mm or round push button with raised tactile letters

**Figure 25 — Example of arrangement of two rows of square or round push buttons**

### 15.6 Use of lifts (elevators) for fire evacuation

A fundamental objective of fire engineering design for evacuation is that there shall be alternative, safe and intuitive evacuation routes away from the scene of a fire, which can occur at any time and in any part of a building; these evacuation routes shall be available to all building users.

**NOTE 1** Manual handling of wheelchairs occupied by their users in a fire evacuation staircase, even with adequate training for everyone directly and indirectly involved, is hazardous for the person in the wheelchair and for those people giving assistance. The weight of an average unoccupied powered wheelchair, alone, makes manual handling impractical. Evacuation chair devices (see 38.4) can allow vertical movement on stairs of people with mobility impairments. Some evacuation chairs require a wheelchair user to transfer out of their own chair into the evacuation chair. This transfer operation requires manual handling (e.g. handling of one work colleague by others), and there is a risk of injury during the transfer process or if the wheelchair user uses an oxygen tube, or has a catheter or a colostomy bag. The transfer can also infringe the independence and dignity of the individual concerned.

All lifts/elevators in new buildings should, therefore, be capable of being used for evacuation in a fire situation. If lifts/elevators in existing buildings undergo a major overhaul, or if they are replaced, they should be made capable of use for this purpose.

**NOTE 2** Requirements for lift cars being used for evacuation are a matter of national building regulation. Sometimes alternative provisions are required.

It is essential that any lift/elevator used for evacuation can continue to operate effectively and safely, under strict management, for a specified time during a fire.

Firefighting lifts/elevators may be used for the evacuation of building users up until the time that firefighters arrive at the building and take control of the lifts/elevators. Prior liaison and pre-planning with local fire authorities is always necessary to agree on suitable procedures with regard to the use of the lifts/elevators.

The use of a firefighting lift for the evacuation of building users may not be acceptable in all countries where national regulations require a separate provision to be made for firefighter access and disable persons egress.

All lifts used for evacuation should be easily accessible, clearly identifiable and be suitably protected from the increase of smoke, heat and flame. The controls for the lift shall be located in the areas where users must wait and this area shall be designed to ensure a tenable environment provided during the entire time that the evacuation is taking place.

Lifts should not be used for evacuation unless built for this purpose and suitably protected by the building design.

The location of lifts/elevators in a building, preferably outside a central position on plan, should always be considered in relation to their supporting fire evacuation staircases, with associated areas of rescue assistance, and direct protected access to final fire exits leading to places of safety remote from the building.

See also Clause 38, and consider D.3.

## 16 Vertical and inclined lifting platforms

### 16.1 General application

Vertical and inclined lifting platforms shall be able to be used safely, independently and also with an accompanying person. All control devices shall also be accessible and usable for powered wheelchair and walking aids users.

*Exceptional considerations for existing buildings:* If it is impossible to install an accessible lift according to Clause 15 in an existing building, vertical or inclined lifting platforms shall be provided. Installation shall comply with ISO 9386-1 and ISO 9386-2.

NOTE ISO lifting platform standards (ISO 9386-1 and ISO 9386-2) were published in 2000 and confirmed in 2007. CEN/TC 10 has recently developed EN 81-40 on Lifting platforms for inclined planes and EN 81-41 on Lifting platforms for vertical planes.

### 16.2 Platform dimensions

The minimum dimension of the platform shall be 1 100 mm × 1 400 mm for the use of manual and powered wheelchairs with assistance.

*Exceptional considerations for existing buildings:* In existing buildings of minor public importance and with few visitors, where sufficient space is not available, other dimensions may be considered, e.g. 900 mm × 1 400 mm or 800 mm × 1 250 mm. Local building regulations should be observed.

### 16.3 Vertical lifting platforms

If driving, guiding or lifting mechanisms present hazards at the sides of a platform, the mechanisms shall be guarded to protect the users. The guarding shall be smooth, hard and continuous.

## 17 Escalators and moving walks

Escalators and moving walks are very common in public buildings. They can greatly facilitate circulation for all building users in large, extensive and complex modern building types.

NOTE No ISO standard is available for escalators and moving walks. CEN/TC 10 has published EN 115-1 which is a harmonized standard for European Member States and is also internationally accepted.

However, the location of escalators and moving walks should always be considered in relation to the position of adjacent fire protected lift/elevator shafts and lobbies, staircases and their associated areas of rescue assistance.

During normal periods of maintenance and servicing, escalators and moving walks will not be operational.

In the event of a fire emergency, building users attempting to evacuate usually tend to re-trace their routes of entry, whatever the nature of the hazard and wherever it is located. It should be assumed that the electrical supply to escalators and moving walks is terminated or turned off during such emergencies.

For important reasons of safety, therefore, inclined moving walks should comply with the requirements for ramps in buildings (see 8.2).

For important reasons of safety, special warning notices and indicators shall be provided at the top and bottom of escalators where step rises reduce suddenly and dramatically when not operational.

Some individuals, in particular older people, might have more than one impairment. Some individuals are not able to use an escalator or moving walk independently and rely on assistance/support being provided by a companion.

Safety shall be the prime consideration when choosing or installing escalators and moving walks.

Lifts are the preferred method of vertical travel for most people with disabilities and in particular wheelchair users and persons with assistance dogs.

Persons with a wheelchair generally cannot use horizontal walkways. An inclination of up to six degrees will exclude a majority of wheelchair users from using a horizontal walkway independently.

A surface of the escalator that contrasts visually with the approach and the use of audible signals or pre-recorded messages that indicate the start and finish of the escalator help blind and partially sighted people. Such signals or recording are not normally provided by the escalator manufacturer as standard. There is no harmonization of solutions worldwide to address this issue. National Standards and National Regulations should be considered.

Signs should be provided to indicate the location of other facilities, such as lifts, and these facilities should be in close proximity to the escalators and moving walks and be easy to find.

Moving walks shall be free of projecting objects and obstacles up to a height of 2 100 mm.

A minimum level of illumination of 100 lux shall be provided on moving walks.

## **18 Doors and windows**

### **18.1 Doors and door furniture**

#### **18.1.1 General**

General requirements for entrance doorways are given in 10.5.

Doorways shall be designed in accordance with the following additional criteria:

- unobstructed width of doors shall be minimum 800 mm; 850 mm or more is recommended,
- clear height of doorways shall be at least 2 000 mm (compare with 10.6),
- a level threshold is recommended for internal and external doors,

- where a raised threshold is provided, it shall have a maximum height of 15 mm, be bevelled when higher than 5 mm and contrast visually with the adjacent floor,
- level manoeuvring area on either side of the door (see Figures 11 and 12),
- if any door is opening towards a descending stair, the minimum safe distance for manoeuvring should be 2 000 mm, including doorswing, to minimize the risk for wheelchair users (see also 13.3 on landings).

### 18.1.2 Unobstructed width of doorways

The minimum unobstructed width of a doorway on a continuous accessible path of travel shall be 800 mm when measured from the face of the door (see Figure 26); 850 mm or more is recommended. Consider detailed information and alternatives in Annex C.

The maximum distance from the handle of the door leaf to the wall surface shall not exceed 250 mm.

Design, installation and maintenance of sliding doors should be specially considered.

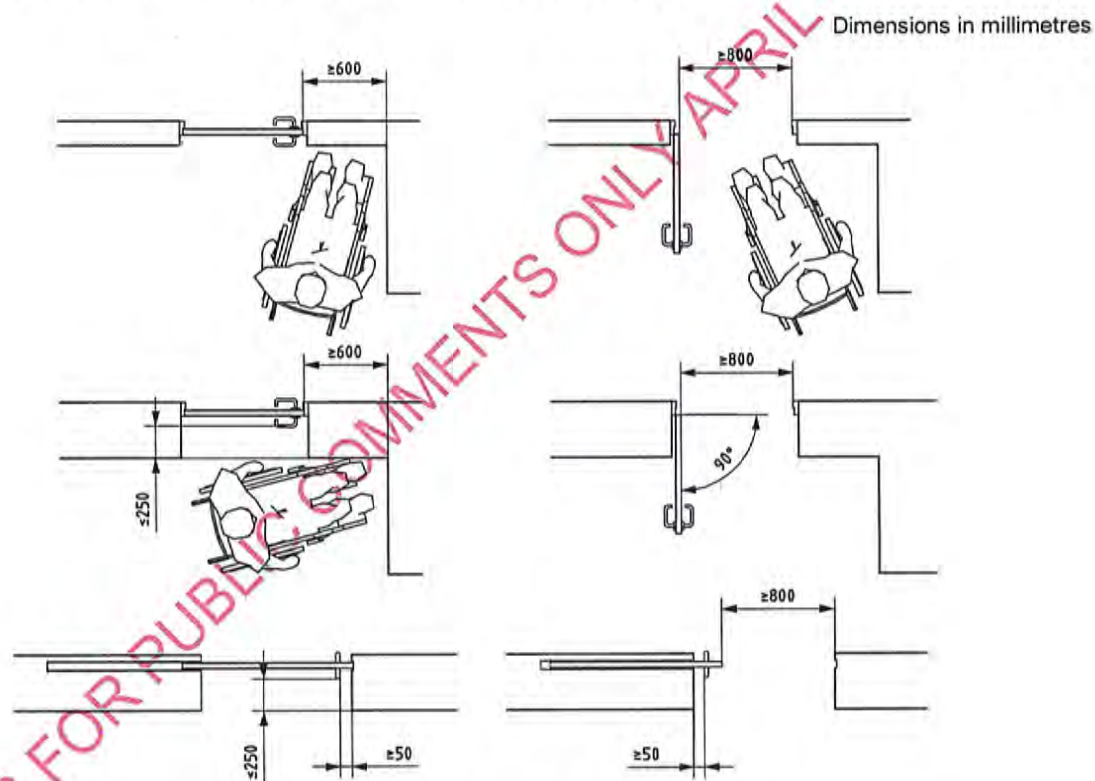

Figure 26 — Unobstructed width of swinging and sliding doors

### 18.1.3 Position of a door

A manoeuvring space of not less than 600 mm shall be provided between the leading edge of a door and a wall that is perpendicular to the doorway as shown in Figure 26; 700 mm or more is recommended. This space is necessary to allow opening of the door by a wheelchair user or a walking frame user. This requirement does not apply where automatic doors are provided.

#### 18.1.4 Operating force

When the operating force needed to open the door is greater than 25 N, an automatic opening door is recommended.

People with impaired mobility often experience difficulties when using self-closing doors. The force required to open doors should be 25 N. Self-closing doors should have an opener.

Buildings for public use should preferably have automatic doors or controlled door closing devices with a hold-open device. An alternative option is the use of dual powered controlled door closing devices with electromagnetic retention for higher power spring.

#### 18.1.5 Glazed doors and glazed areas

Glazed (glass) walls and fully glazed doors shall be clearly marked with visual indicators (see Figure 27). Large glazed areas close to circulation spaces could be mistaken for openings. Glazed walls, doors and other areas of full height glazing are very disorientating for blind or partially sighted people. The reflections from these surfaces can be particularly confusing.

Uninterrupted visual indicators of at least 75 mm height with a difference in light reflectance values of minimum 30 points to the background shall be placed at a height of 900 mm to 1 000 mm and 1 300 mm to 1 400 mm above floor level. An additional visual indicator placed at a height of 100 mm to 300 mm is recommended (see Figure 27). Visual indicators consisting of two separate colours with a minimum difference in LRV of 60 points are recommended to enable lighting conditions and backgrounds to be taken into account.

Glass that is silvered or highly reflective should be avoided and any free-standing edges of glazed screens should have a strip contrasting visually with the surroundings against which they are seen.

**NOTE** The visually impaired can have a depth of field limitation, which results in them looking down at an angle of 45° to 50°. This also allows them to choose a safe path of travel. When they are within 1 000 mm to 1 500 mm from a fully glazed door or sidelight, they are able to detect the visual barrier at a height of 900 mm to 1 000 mm, provided the visual contrast criteria have been applied to the background. The background in all cases is the circulation space on the opposite side of the door.

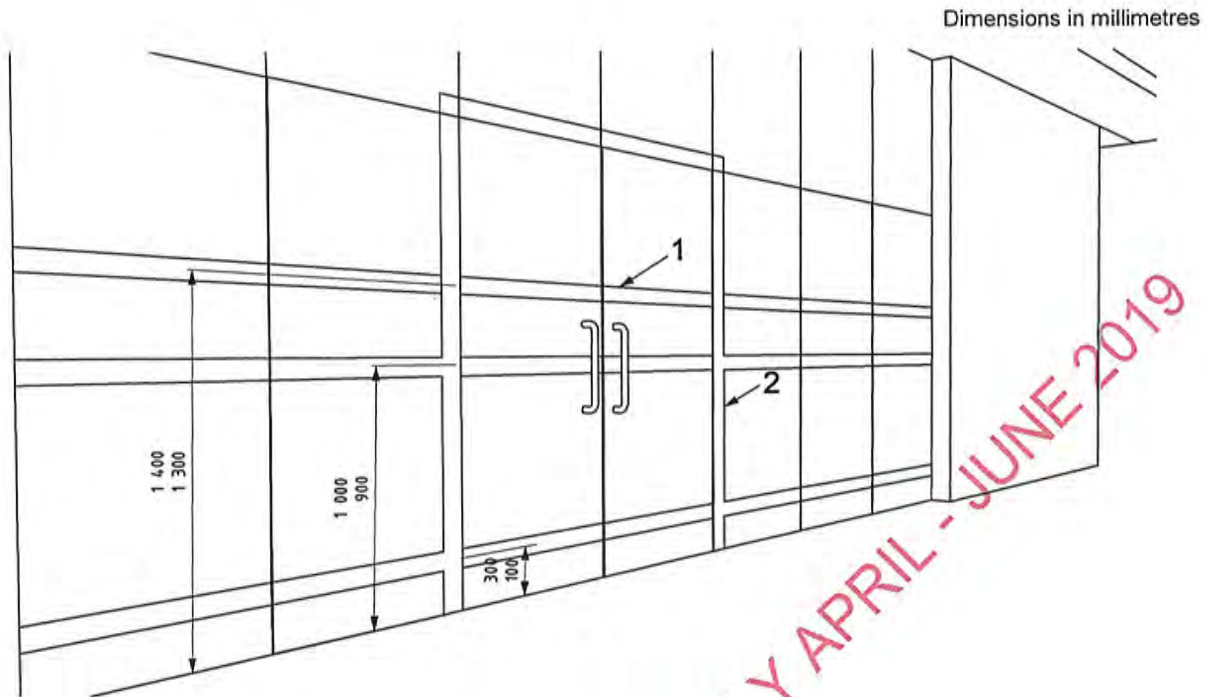

**Key**

- 1 visual marking, minimum width 75 mm, two separate colours with a minimum difference in LRV of 30 points are recommended
- 2 visual marking on door frame, minimum width 50 mm

**Figure 27 — Markings on glazed doors**

**18.1.6 Viewing panels in doors**

If viewing panels are provided, they shall comply with the following requirements (see also Figure 28):

- the lower edge of the glazed panel shall be not more than 600 mm above the finished floor,
- the upper edge of the glazed panel shall be not less than 1 600 mm above the finished floor,
- in width, the glazed panel shall start not more than 200 mm from the latch edge of the door, and the glazing shall be not less than 150 mm wide,
- the glazed panel may be subdivided by narrow construction cross-sections of a maximum width of 200 mm.

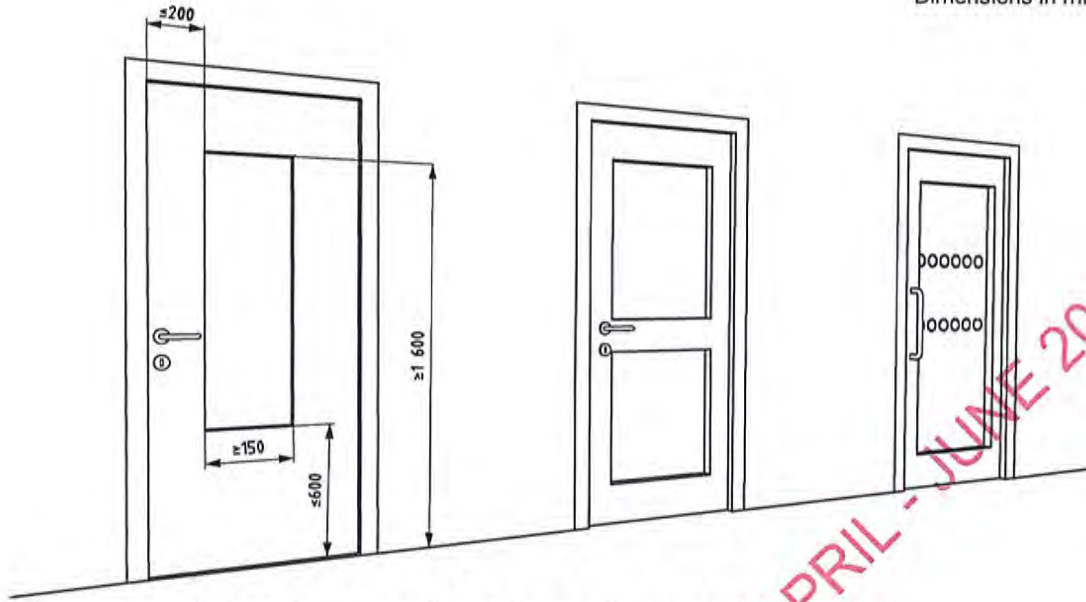

Figure 28 — Examples of doors with glazed viewing panels

#### 18.1.7 Visual contrast of doors and door furniture to the wall

Doors forming part of an accessible path of travel shall have a difference in light reflectance value to doorframe and the surrounding wall of not less than 30 points, as described in Clause 35.

The minimum width of the area of visual contrast shall be 50 mm.

If this is not possible to achieve, a marking of at least 50 mm width (e.g. around the frame of the door), with a different visual contrast from the wall (with a minimum difference in LRV of not less than 30 points) shall surround all the perimeter of the door (see Figures 27 and 29).

There should be a visual contrast between the door leaf and the handle of at least 15 points.

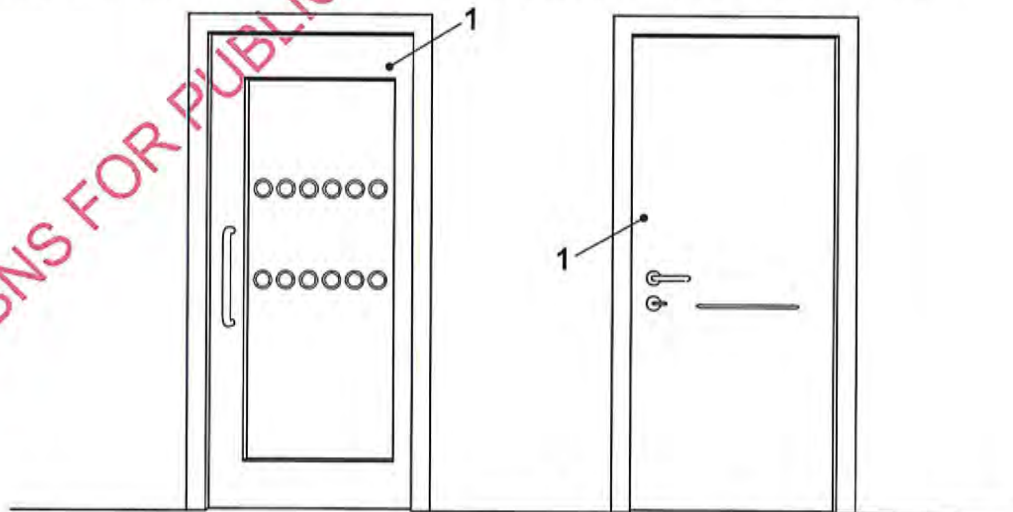

**Key**

- 1 minimum difference in LRV 30 to door frame and wall

Figure 29 — Door with sufficient visual contrast

### 18.1.8 Automatic opening doors

The minimum unobstructed width shall be at least 800 mm, with 850 mm recommended. In narrow spaces, automatic sliding doors can be preferable. All automatic doors should be capable of remaining totally open (at least 90° in the case of hinged doors) without manual support (see 36.3 and Figure 30).

Dimensions in millimetres

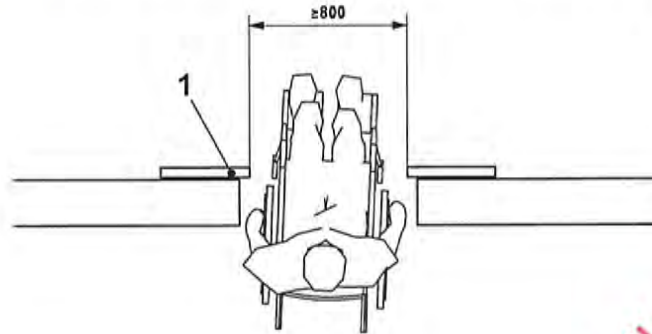

#### Key

- 1 automatic sliding door

Figure 30 — Automatic sliding door

### 18.1.9 Powered swing door

A powered swing door shall be:

- provided with a suitable detection device that is set to ensure that a person approaching or leaving the door does not come into contact with the door during the opening and closing phases;
- fitted with a return delay mechanism that allows sufficient time for safe passage and for detecting the presence of a person lying on the floor within the door closing area;
- capable of being used manually in the event of electrical failure.

### 18.1.10 Revolving door

Where a revolving door is used, a complementary accessible door should be provided immediately adjacent to the revolving door and available for use at all times. The accessible door could be a swing, sliding or folding door, and be automatic, manual or power-operated. It should be clearly identified and signed to show that it is accessible (see Figure 31).

**NOTE** Unless of significant size and power-operated, revolving doors are not suitable and present particular difficulties to ambulant disabled people, blind and visually impaired people, people with assistance dogs, wheelchair users, and people with young children (see Figure 31). Revolving doors are generally not suitable for use as fire exits.

A revolving door shall be large enough to allow safe passage and accommodation for a wheelchair user and a companion.

An automatic revolving door shall be equipped with a means to slow it or to stop it if it is subjected to pressure or resistance.



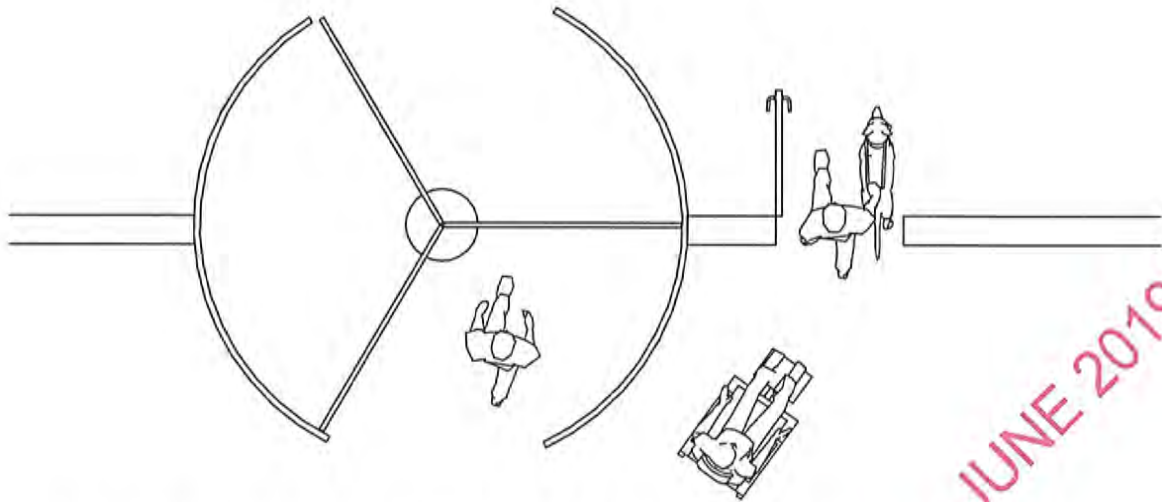

**Figure 31 — Revolving door accompanied by door suitable for people who walk slowly, use a wheelchair or have impaired sight**

#### **18.1.11 Automatic sliding or folding door**

An automatic sliding or folding door shall be equipped with a mechanism to prevent its colliding with a user and anything that is being pushed, pulled or otherwise, being transported through the doorway.

Doors should not obstruct the flow of people or create a collision hazard. The door shall never obstruct the escape route.

#### **18.1.12 Door furniture**

Door locks, door handles, bells and other devices for gaining entry to a place shall be easy to locate, identify, reach and use, and shall be operable with only one hand. Door furniture shall be located between 800 mm and 1 000 mm in height, preferably 900 mm (consider B.6.3 and B.6.4 also). D-lever handles are preferred (see Figure 57).

Adequate clear space shall be available on either side of the doors to enable people in wheelchairs to access the door controls and pass through. Consider 18.1.2 and Figures 11 and 12.

#### **18.1.13 Glazed walls and screens**

Glazed walls and glazed screens should be marked as stated in 18.1.5.

### **18.2 Fire resisting doorsets**

Special consideration should be given to the choice of closing device for a fire resisting doorset. It should be easily openable from the inside without the use of a key. The door leaf should always be easy, intuitive and obvious for everyone to open, whatever its configuration, dimensions or hardware.

Where the weight of fire resisting doorsets may cause difficulties for people with mobility impairments, devices can be used (where permitted by local fire regulations) to hold open these doors during normal use, and close automatically when an emergency alarm is raised. Care should be taken to ensure that the opening force of these doors does not prevent them being used by people with mobility impairments during evacuations.

See 18.1 for the detailed requirements and recommendations concerning any doorset in a building.

## 18.3 Windows and window hardware

### 18.3.1 Restriction on opening

Opening windows shall not project into pedestrian areas below a height of 2 100 mm.

### 18.3.2 Manoeuvrability of hardware and shutters

Windows should be easy to open and close. It should be possible to open and close the windows with only one hand.

Windows that are easy to open may need safety devices that prevent children from falling out.

Hardware, shutters and switches for remote control should be placed between 800 mm and 1 100 mm above the floor (see Figure 32).



Figure 32 — Heights of hardware and shutters

### 18.3.3 Height of the window

To enable wheelchair users to see through a window, the lower edge of the glazing should be no higher than 1 100 mm from the floor.

For safety reasons, guards should be considered, according to building regulations.

### 18.3.4 Visual indication of glazed areas

Consider the requirements stated in 18.1.5 and Clause 35.

## 19 Reception areas, counters, desks and ticket offices

### 19.1 Hearing and lip-reading

Reception areas, counters, ticket offices, especially in noisy environments or those equipped with a separating security screen, shall have at least one position fitted with a hearing enhancement system (e.g. induction loop system) to assist hearing-aid users, as described in Clause 32, and be clearly marked with the appropriate symbol (see Clause 41).

Avoid positioning service counters in front of windows where bright sunshine causes the user's face to be in shadow and hence difficult to lip-read. Service counters equipped with a service screen are particularly difficult. Reflections and glare should be avoided.

### 19.2 Location

Counters and reception desks should be located and clearly identified so that they are easily recognisable from a building entrance. Information reception areas should be positioned near the main entrance. Wayfinding specified in 7.2 and orientation specified in Clause 39 should also be considered.

Carpets or entrance flooring systems or tactile walking surface indicators can help in locating reception counters for people who have vision impairment. Such products should be designed to minimize trip and slip hazards.

General design requirements for colour and visual contrast should be considered (see Clause 35).

### 19.3 Space to manoeuvre

Counters, desks and ticket offices should be accessible to wheelchair users on both sides. A clear manoeuvring space at least 1 500 mm square shall be provided in front of the counter on the receptionist's side and on the visitor's side; 1 800 mm square is preferred.

### 19.4 Height

The counter level shall be between 740 mm to 800 mm from the floor. Clear knee space underneath shall be minimum 700 mm (see also Figure 33).

Reception desks where writing is done by the visitor (for example at hotel receptions) should allow frontal approach by wheelchair users with space to provide clearance for wheelchair user's knees. The counter level shall be between 740 mm to 800 mm from the floor. The clear knee space underneath shall be at least 700 mm (see Figure 33). At least a part of the desk should also be at a height suitable as a writing place for standing people, between 950 mm and 1 100 mm (see Figure 33).

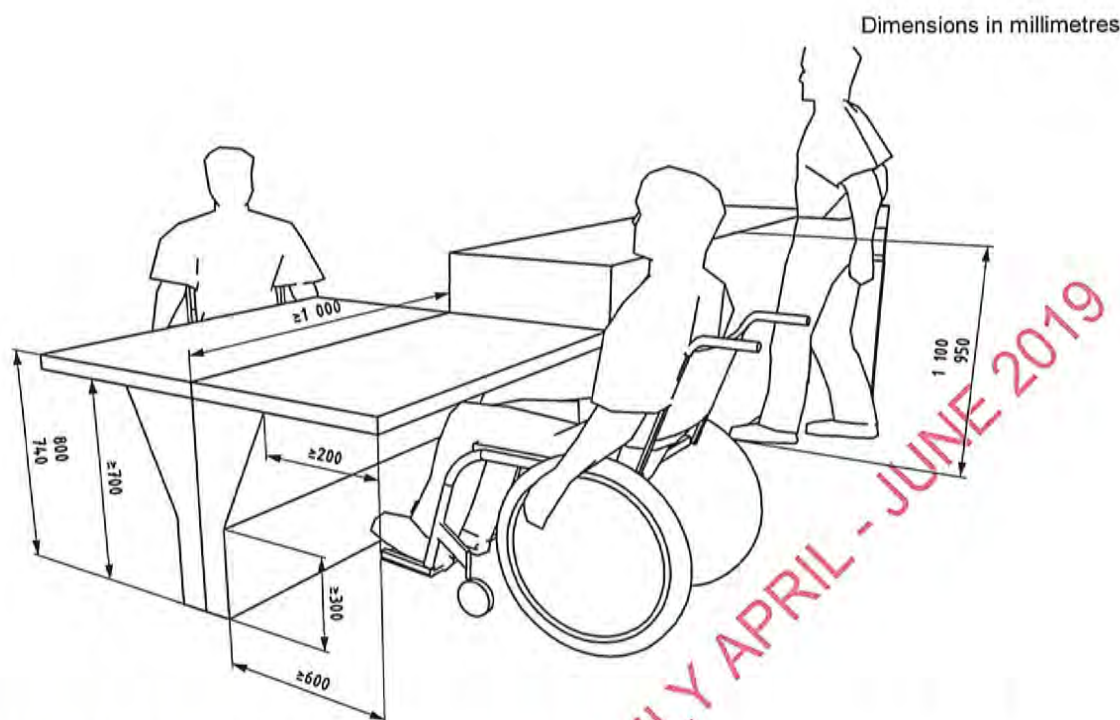

**Figure 33 — Heights of counters suitable for wheelchair users and people standing**

## 19.5 Lighting

To facilitate lip reading, lighting should provide even illumination.

The reading and writing surfaces at counters, desks and ticket offices shall be illuminated to a level of at least 200 lux in the room, and on the desk in a range of 350 lux to 450 lux.

## 19.6 Ticket systems

If a queue number ticket system is used, it shall be suitably designed to be accessible. All control devices shall be located according to Clause 36, and B.6.3 and B.6.4 should be considered. All necessary information shall be given in simple wording with sufficient visual contrast and based on the two-sense-principle (consider Clauses 32, 35 and 36). The ticket machine and the calling system shall provide visual and audible output.

Some seats should be located so that a guide or assistance dog can accompany its owner and rest in front of, or under, the seat.

## 20 Cloakroom

A mirror should be usable from a standing or a sitting position.

A chair with armrests is required for people who need to sit down and stand up (see 37.2).

Coat hooks should be set at different heights: some at 850 mm, some at 1 100 mm and others at 1 800 mm.

## **21 Auditoriums, concert halls, sports arenas and similar seating**

### **21.1 Hearing enhancement systems**

A hearing enhancement system shall be provided. The system shall also be provided on the stage/platform. Consider requirements in Clause 32.

### **21.2 Lighting for sign language interpretation**

Adequate provision should be made to facilitate sign language and lip reading. Lighting on the faces and hands of presenters and people signing should be provided at an angle of 45° to 50° from horizontal at ceiling level for people with a hearing impairment to be able to read the presenter's lips and the signer's lips and hands. A suitable contrasting backdrop should be provided, to assist in reading the presenter's lips and hands.

### **21.3 Designated seating areas for wheelchair users**

At least 1 % of seats shall be designated as seating areas (see 23.1) for wheelchair users, with a minimum of two.

From 51 seats up, it is recommended to rate the designated seating areas this way:

- total seats 51 to 100, minimum three designated seating areas for wheelchair users;
- total seats 101 to 200, minimum four designated seating areas for wheelchair users;
- one additional seating area should be provided for every two hundred additional seats or part thereof.

These spaces should be integrated among other seats and allow two wheelchair users to stay together. It is recommended that the armrest on the seats at the end of the row lift up to allow people to transfer from the wheelchair onto a seat. To accommodate groups of wheelchair users, in an auditorium with fixed seats, a minimum of 15 seats shall be foldable or removable to increase the number of designated areas for wheelchair users when necessary.

Some seats should be wider in order to allow larger size people to sit properly.

### **21.4 Access to stage and backstage**

Access to the stage and to the backstage area shall be provided in new buildings. Adequate provision should be made to direct the user to the designated spaces.

### **21.5 Row and seat numbers**

The row and seat numbers should be legible to people who have impaired vision. They should be tactile, of adequate size and have enough visual contrast to the background on which they are mounted. The requirements given in Clauses 35 and 40 should also be considered.

### **21.6 Accessible changing rooms**

The minimum number of accessible changing rooms can be subject to national requirements or regulations, depending on the type and use of the building.

In the event that changing rooms are provided alongside a toilet area, these should comply with the specifications indicated in Clause 26.

A fixed bench should be set at a height of 400 mm to 480 mm above floor level. The anthropometric differences in the population worldwide may require lower or higher heights of toilet seats. The bench should

be no less than 500 mm wide × 2 000 mm in length, and be provided with a grab rail at a height of 750 mm with a clearance of between 45 mm and 65 mm from the wall.

A clear space of 1 500 mm × 1 500 mm shall be beside the bench.

Coat hooks should be set at different heights: 850 mm to 1 100 mm, and additionally at least one hook at 1 800 mm.

Coat hooks, benches, locker handles and other furnishings should offer good colour and tonal contrast to their backgrounds. Non-slip floor surfaces should be used, and good lighting as well as matte finished surfaces and furnishings should be provided.

A call bell may be provided in accordance with Clause 36.

Changing rooms shall have a minimum area of 4 m<sup>2</sup>.

## 22 Conference rooms and meeting rooms

Consider the requirements for accessible sanitary facilities in Clause 26 and sufficient acoustic provision in Clause 32. A sound augmentation system should be provided. Reverberation time for speech, music, etc., should be given by national provisions.

All equipment in conference rooms shall be usable by people chairing or participating in the meeting and shall be at a height between 800 mm to 1 100 mm. See also 36.2.

## 23 Viewing spaces in assembly areas

### 23.1 Floor area

The floor area for a wheelchair viewing space shall be connected to an accessible path of travel and shall meet the following requirements (see Figure 34):

- at least 900 mm × 1 400 mm,
- the depth of the row shall be minimum 2 400 mm,
- clear and level surface,
- sufficient manoeuvring space,
- spaces for several wheelchair users shall be provided. They shall be located beside regular seating rows, for the wheelchair user to be able to stay by his/her accompanying person, if relevant,
- it is recommended that the armrest on the seats at the end of the row lift up to allow wheelchair users to transfer from the wheelchair onto a seat.

Some seats should be provided with foldable armrests, considering transferences (see 21.3); some other seats should be wider, considering larger size people.

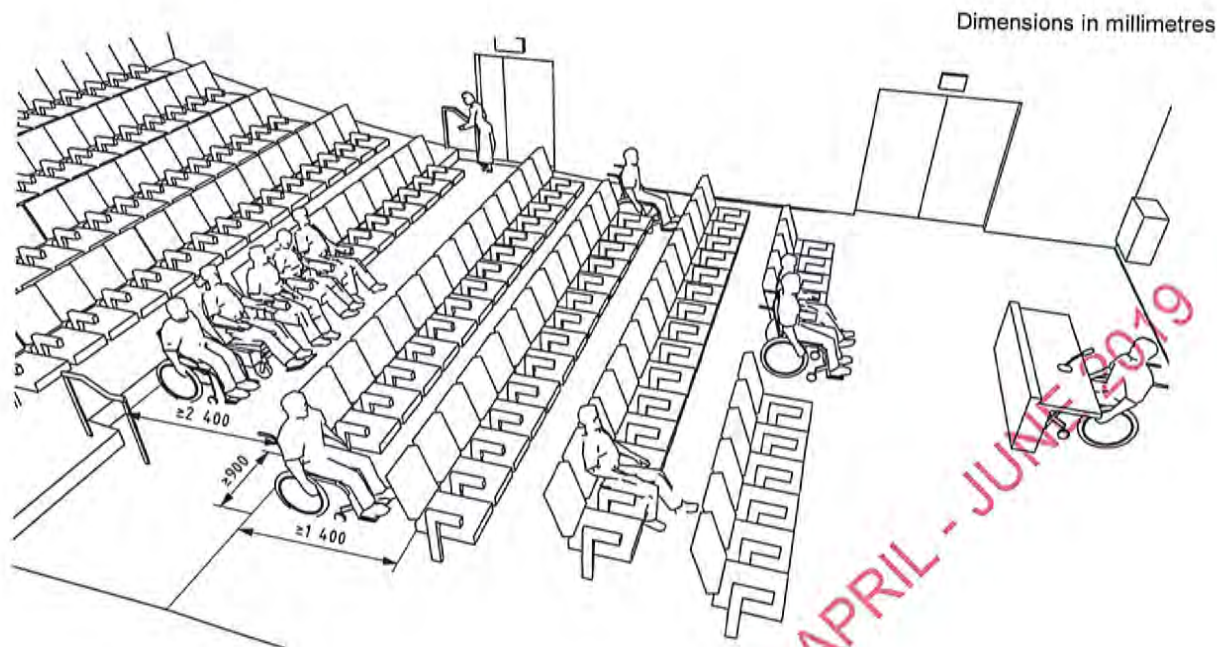

Figure 34 — Examples of viewing spaces for wheelchair users

### 23.2 Sight lines

Wheelchair user viewing spaces shall provide viewing spaces that are:

- comparable to those for all viewing positions with a minimum unobstructed eye level up to 1 200 mm,
- not reduced or obstructed by standing members of the audience.

Row and seat number identification signs shall be legible to persons who are visually impaired (see 40.5).

### 24 Bars, pubs, restaurants, etc.

In restaurants a minimum of 25 % of the tables shall be usable by wheelchair users according to 37.3. In bars, a minimum of 25 % of bar counters shall not be more than 800 mm height, and shall have an unobstructed lateral access for wheelchair users.

Sufficient manoeuvring space between tables and the route to the accessible sanitary facilities shall be provided (consider Clauses 4, 10, 18.1, 26, 30.1 and B.6.1).

Consider the acoustic recommendations in Clause 32.

The general design requirements for colour and visual contrast should also be considered, as described in Clause 35.

### 25 Terraces, verandas and balconies

Terraces, verandas and balconies shall be accessible to all people, including people with mobility impairments.

Parts of these facilities should be covered with a canopy, to give shelter against the weather (sun/rain/snow).

Walking surfaces shall be slip resistant.

## 26 Toilet rooms and sanitary rooms

### 26.1 General

The requirements contained in this clause apply to buildings in use by the public, for example hotels, work places, public buildings and buildings used for sport and recreation activities.

Sanitary facilities shall be designed to accommodate a variety of users. Users with colostomy should also be considered.

There are a variety of approaches in providing wheelchair accessible toilet rooms. The selection shall be carefully selected to meet the needs in each country.

If no other national requirements or regulations are available, the following shall apply:

- at least one wheelchair accessible toilet room shall be provided,
- the wheelchair accessible toilet room shall always contain a washbasin.

National provisions may give the number and type of toilet rooms (lateral transfer from two sides or corner toilet), taking into consideration the type and use of the building and circumstances in which unisex or single sex provision would be acceptable.

Accessible toilets that can be used by both sexes allow the greatest flexibility for people who require assistance.

Consider signage requirements given in Clause 40. Consider the use of Figures 68 to 70, given in Clause 41, to indicate accessible toilet rooms.

An emergency assistance alarm according to 26.14, including a reset control, should be provided in all toilet and sanitary rooms.

### 26.2 WC compartments for ambulant disabled people

These compartments meet the needs of ambulant disabled people who require support. This type of compartment is not for the majority of people who use wheelchairs (see Figure 35). Where located in a single-sex washroom, hand washing facilities will be available communally. Where this is a standalone facility, hand washing facilities shall be provided either in a space adjacent to the WC compartment or in a compartment enlarged to accommodate a wash hand basin.

Characteristics:

- toilet seat height, depth and distance to wall should comply with 26.6,
- clear manoeuvring space in front of the toilet should be minimum 900 mm × 900 mm,
- the door should open outwards, with a minimum unobstructed width of 800 mm,
- grab rails on both sides of toilet,
- independent water supply beside toilet seat, and floor drain where necessary.



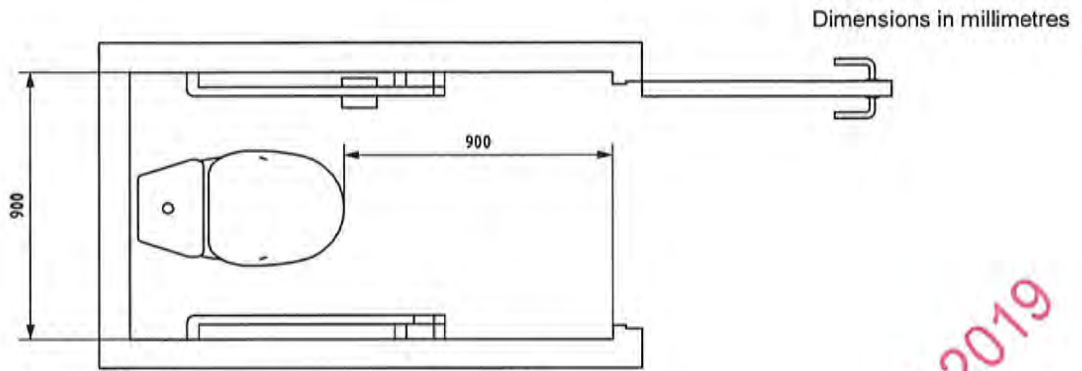

Figure 35 — Ambulant toilet

### 26.3 Wheelchair user accessible toilet rooms

Fixtures and fittings in sanitary facilities should visually contrast with the items and surface on which they are positioned.

The minimum illumination measured at 800 mm above floor level shall be 200 lux in the area of the washbasin.

The floor surface shall be slip resistant, anti-glare and firm.

Light switches should be fixed inside all accessible toilet cubicles or the light should automatically switch on when someone enters the room. Timed light switches should not be installed or used.

### 26.4 Dimensions for wheelchair user accessible toilet rooms

#### 26.4.1 General

The dimensions for wheelchair user accessible toilet rooms depend on the functions they must meet. This International Standard gives the characteristics and requirements for the three types (A, B, C) of toilets most commonly used in the world. National regulations shall decide on the priority of the functions to be met and recommend which type of toilet room is to apply for different building types and which type is acceptable for existing buildings.

The clear manoeuvring space of the toilet room shall allow frontal, oblique and lateral transfer.

Type A allows right and left lateral transfer, and may be more suitable when assistance is needed. Types B and C only allow one side transfer.

When more than one accessible corner toilet type B or C is planned, a choice of layouts suitable for left hand and right hand transfer should be provided. Layout of wheelchair user accessible toilet rooms should provide toilets usable by both sexes.

The clear manoeuvring space at floor level in front of the toilet seat and the washbasin shall be 1 500 mm × 1 500 mm, except for type C where 300 mm under the washbasin is accepted as part of the total manoeuvring space.

The minimum free clearance beside the toilet seat shall be 900 mm; 1 200 mm is preferred for lateral transfer and assistance.

**NOTE** Minimum clearance of 900 mm accommodates only 65 % of the wheelchair users, clearance of 1 200 mm accommodates 90 % of all wheelchair users especially also those who use powered wheelchairs.

The minimum dimensions for an accessible corner toilet room are 1 700 mm width and 2 200 mm depth.

*Exceptional considerations in existing buildings:* If the measures given above cannot be achieved due to technical reasons, the manoeuvring space at floor level may be reduced, but it should be recognized that such a reduction limits the number of people who can use these toilet rooms.

#### 26.4.2 Type A toilet room with lateral transfer from both sides

Characteristics (see Figures 36 and 37):

- lateral transfer from both sides,
- manoeuvring space uninterrupted by washbasin and pan,
- independent water supply beside toilet seat,
- horizontal grab rails at both sides,
- toilet paper dispensers on both folding grab rails.

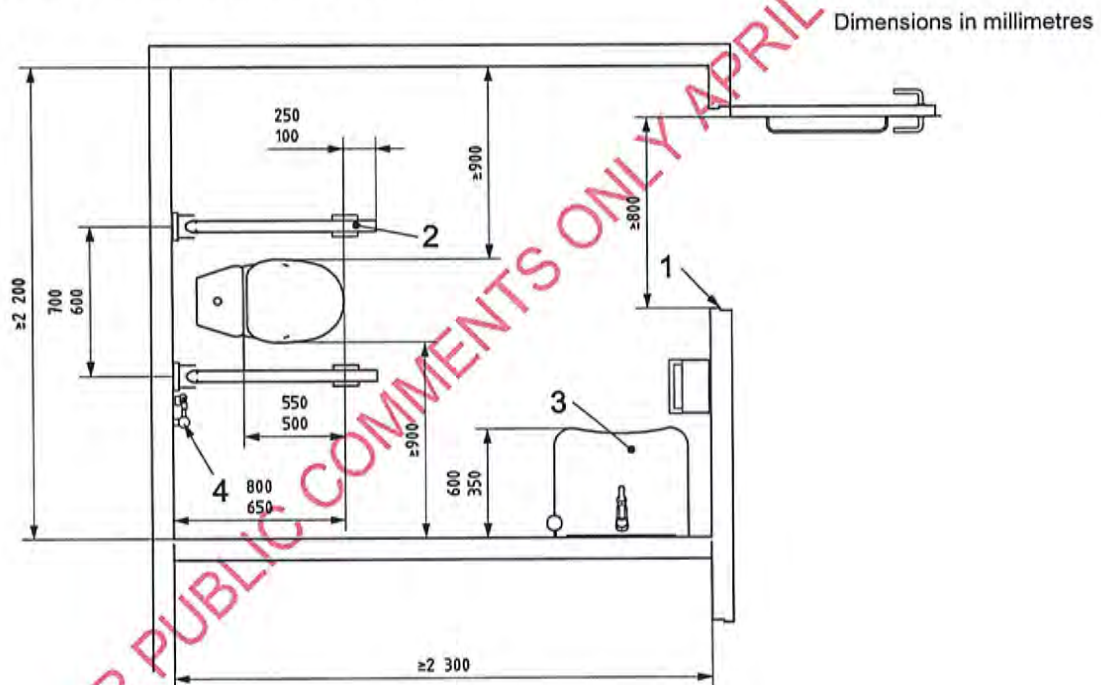

#### Key

- 1 minimum 800 mm (850 mm recommended)
- 2 foldable grab rails, both sides
- 3 washbasin
- 4 independent water supply

Figure 36 — Example of type A toilet room — Lateral transfer from both sides

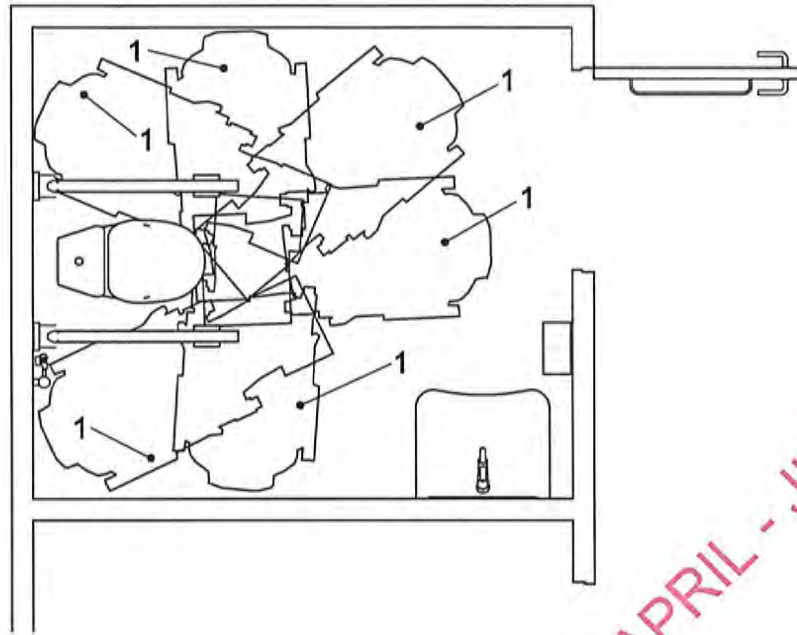

**Key**

1 possible transfer positions

**Figure 37 — Type A toilet room transfer options**

**26.4.3 Type B corner toilet room**

Characteristics (see Figures 38 and 39):

- lateral transfer only from one side,
- manoeuvring space uninterrupted by washbasin and pan,
- independent water supply beside toilet seat,
- vertical grab rail beside the toilet seat for getting up and sitting down (slanted grab bars are not preferred),
- toilet paper dispenser fixed on the wall beside the toilet seat,
- foldable grab rail.

Dimensions in millimetres

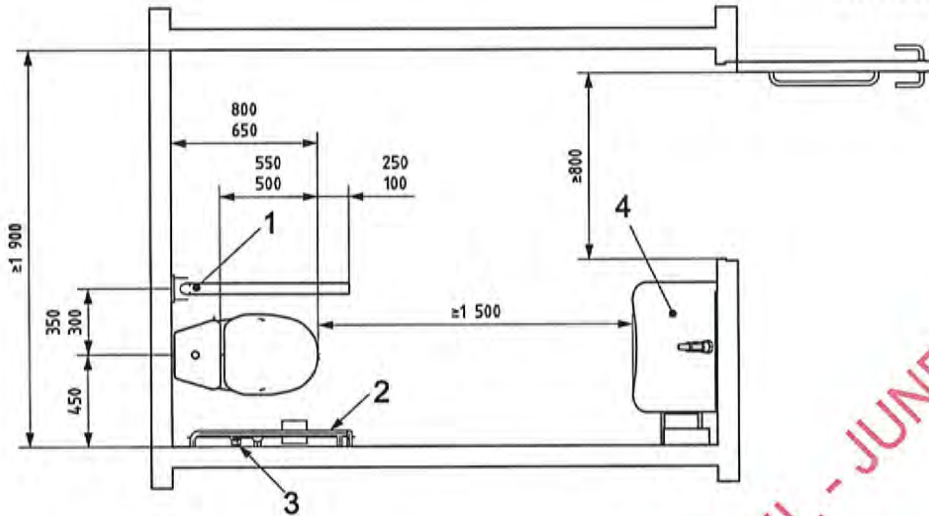

**Key**

- 1 foldable grab rail
- 2 grab rail on wall
- 3 independent water supply
- 4 washbasin

**Figure 38 — Example of type B large corner toilet room**

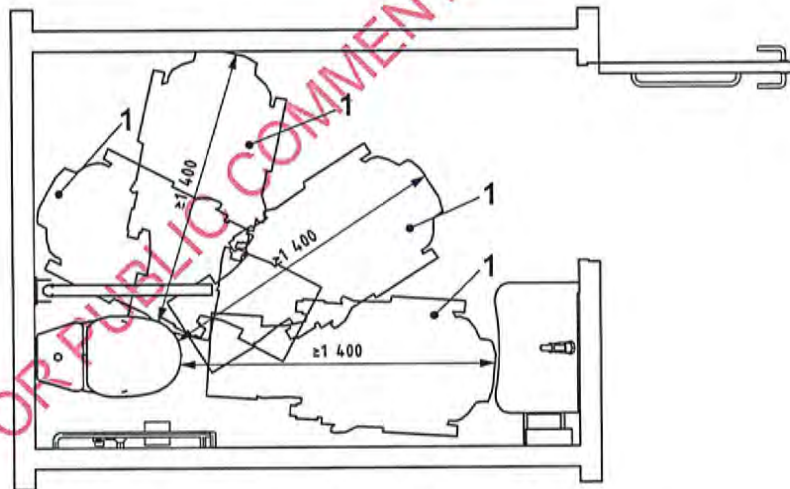

**Key**

- 1 possible transfer positions

**Figure 39 — Type B toilet room transfer options**

#### 26.4.4 Type C toilet room

Characteristics (see Figures 40 and 41):

- lateral transfer only from one side,
- manoeuvring space reduced by washbasin,
- independent water supply beside toilet seat, with floor drain where necessary,
- ability to reach small wash hand basin when seated on toilet,
- horizontal grab rail on wall beside the toilet seat,
- vertical grab rail on wall beside the toilet seat for getting up and sitting down (slanted grab bars are not preferred),
- foldable grab rail,
- toilet paper dispenser fixed on the wall beside the toilet seat.

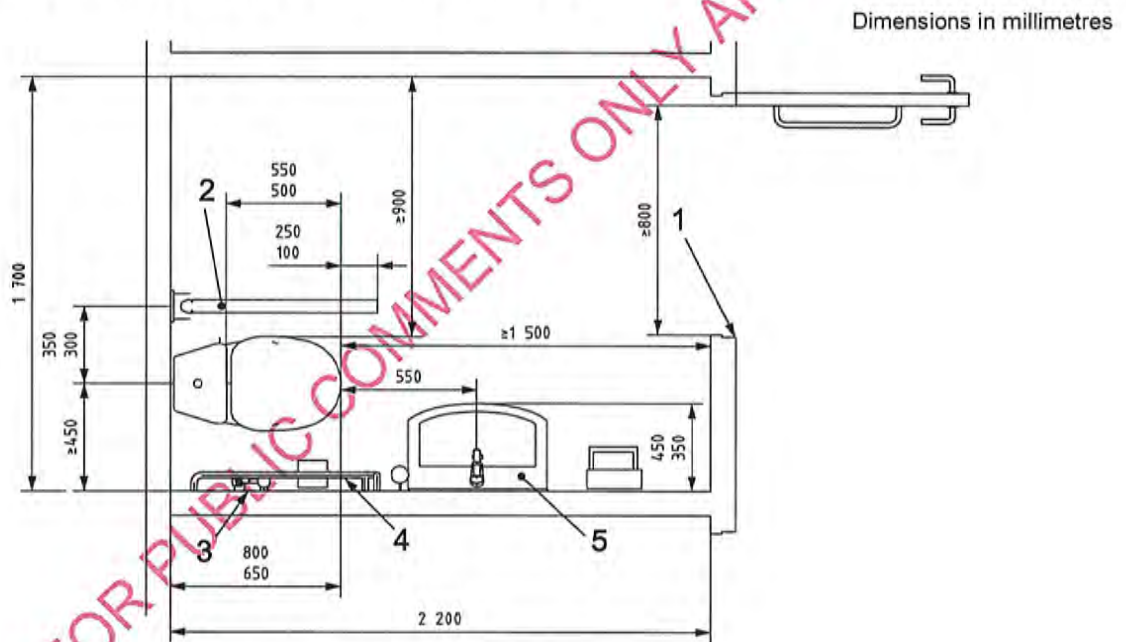

#### Key

- 1 minimum 800 mm (850 mm recommended)
- 2 foldable grab rail
- 3 independent water supply
- 4 grab rail on wall
- 5 washbasin

Figure 40 — Example of type C small corner toilet room

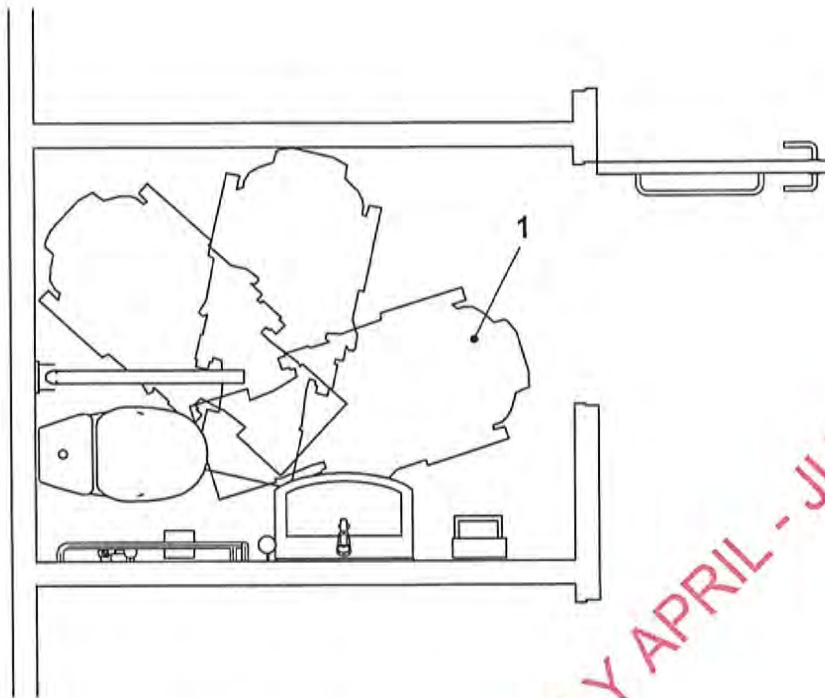

**Key**

1 possible transfer positions

**Figure 41 — Type C toilet room transfer options**

**26.5 Toilet room doors**

Toilet room doors should comply with the specifications indicated in 18.1.

The door shall have an unobstructed width of at least 800 mm, with minimum 850 mm as a recommended value, and it shall be easy to open and close. The door should open outwards. If the door opens inwards, there shall be a way to open the door, or remove it, from the outside. There should be no openings under or above the door.

**26.6 Toilet seat**

The top of the toilet seat shall be between 400 mm and 480 mm from the floor. The anthropometric differences in the population worldwide may require lower or higher heights of toilet seats.

**NOTE** Toilet seats with a height of more than 460 mm may cause a problem of instability when sitting on the toilet seat. Toilet seats of less than 460 mm may cause a problem of transfer getting back to the wheelchair. National regulations may give the most convenient and appropriate height for an accessible toilet seat at a national level.

The minimum distance from the edge of the toilet seat to the rear wall should be between 650 mm and 800 mm (see Figures 36, 38 and 40).

The minimum distance of a corner toilet from the pan to the adjacent wall should be 250 mm (see Figure 38). The minimum distance from the centre line of a corner toilet to the adjacent wall should be 450 mm (see Figures 38 and 40).

If a backrest is provided, the distance from the seat to the backrest should range between 500 mm and 550 mm.

Toilets for children should have a distance from the centre line to the adjacent wall between 305 mm to 380 mm. The toilet seat height shall be between 205 mm to 380 mm.

## 26.7 Grab rails

On both sides of a toilet, a grab rail (whether drop-down or fixed to the wall) shall be provided at a distance between 300 mm to 350 mm from the centre of the toilet. The minimum distance from the wall should be 40 mm.

On the sides where a lateral transfer is possible, a foldable grab rail (drop-down support rail) shall be provided at a height of 200 mm to 300 mm above the toilet seat. Grab rails shall withstand minimum 1 kN force from any direction, with 1,7 kN as a recommendation. The length of the foldable grab rail should overlap the front edge of the toilet seat in between 100 mm and 250 mm. The positioning of a foldable grab rail should allow access from a wheelchair when folded up.

Where a wall is beside the toilet, a horizontal grab rail shall be provided at a height of 200 mm to 300 mm above the toilet seat, and a vertical grab rail shall extend from the horizontal grab rail to a height of 1 700 mm above floor level. The grab rail shall extend a distance of minimum 150 mm to the front edge of the toilet seat.

The horizontal grab rail shall be uninterrupted for its full length.

The grab rail height for toilets for children should be between 510 mm to 635 mm.

Grab rails shall have a circular profile of not less than 35 mm and not more than 50 mm diameter.

The positioning of accessories such as hand towel, soap, waste bin, etc., should not hamper the use of the grab rail.

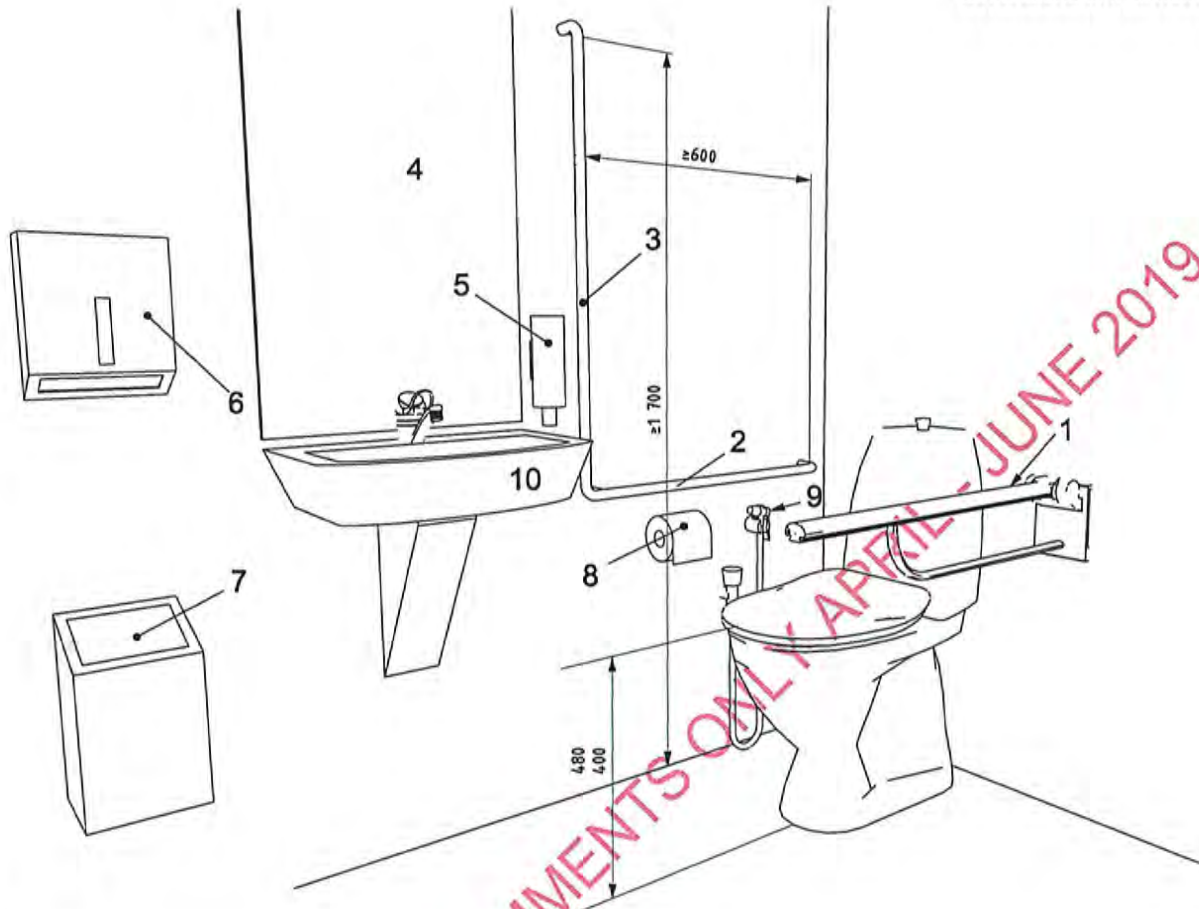

**Key**

- 1 drop down support rail at seat height plus 200 mm to 300 mm
- 2 wall mounted horizontal grab rail at seat height plus 200 mm to 300 mm
- 3 wall mounted vertical grab rail
- 4 mirror, top height min. 1 900 mm, bottom height max. 900 mm above floor
- 5 soap dispenser 800 mm to 1 100 mm above floor
- 6 towels or dryer 800 mm to 1 100 mm above floor
- 7 waste bin
- 8 toilet paper dispenser 600 mm to 700 mm above floor
- 9 independent water supply
- 10 small finger rinse basin maximum 350 mm projection

**Figure 42 — Positioning of grab rails, water supply and toilet paper in type C corner toilet**

**26.8 Toilet paper**

Dispensers for toilet paper shall be reachable from the toilet seat, either under the grab rail or on the side-wall of a corner toilet at a height between 600 mm to 700 mm from the floor (see Figure 42).



## 26.9 Washbasin

A washbasin shall be provided within an accessible toilet room (see Figure 43).

The positioning of a washbasin should allow access from a wheelchair.

The top of the washbasin should be located between 750 mm to 850 mm from the floor.

The differences in stature of the population worldwide may require lower or higher heights of washbasins. National regulations may give the most convenient and appropriate height for washbasins at a national level.



**Figure 43 — Placement of washbasin and mirror above the washbasin with distance of sanitary appliance**

The space under the washbasin shall be unobstructed with a knee clearance centred on the washbasin between 650 mm and 700 mm high and 200 mm deep. In addition, a toe clearance of at least 300 mm high shall be provided (see Figure 44).

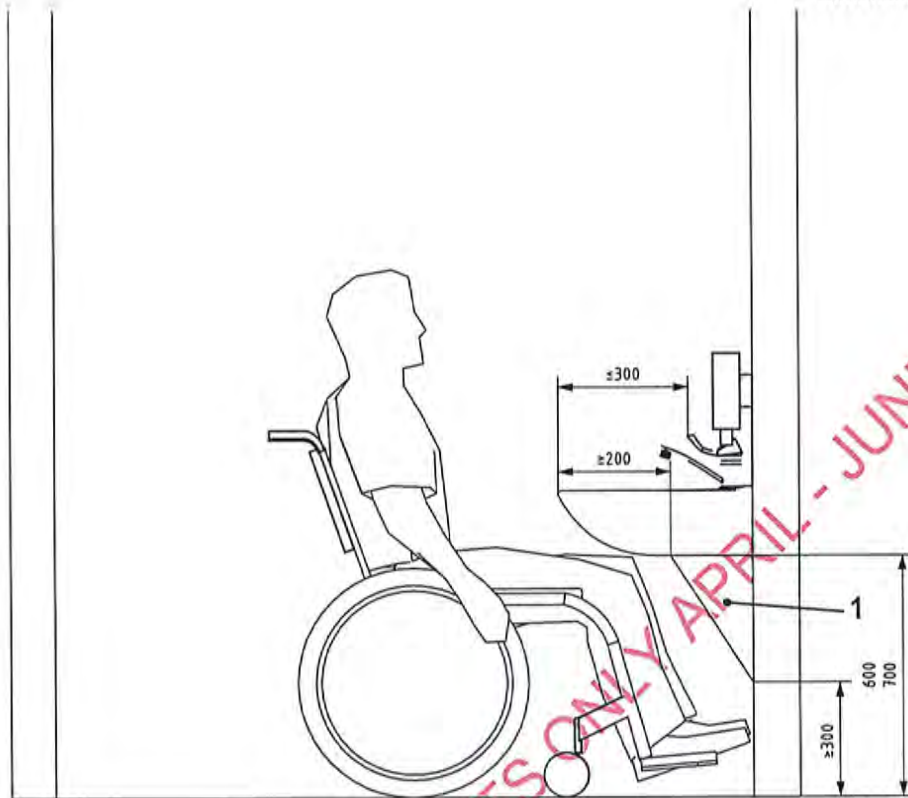
**Key**

1 concealed piping

**Figure 44 — Washbasin with knee/toe clearance**

In front of the washbasin, space should allow for a frontal or oblique approach by a wheelchair.

The front edge of the washbasin shall be located within a distance of 350 mm to 600 mm from the wall, according to Figure 36.

The reaching distance to the tap control shall be a maximum of 300 mm, according to Figure 44.

The mirror above the washbasin shall be positioned at a maximum of 900 mm above the floor, up to a height of 1 900 mm (see Figure 43). If a second mirror is provided, the maximum height above the floor should be 600 mm, up to 1 850 mm.

A shelf with minimum dimensions of 200 mm × 400 mm shall be provided near the washbasin at a height of 850 mm, or combined with the washbasin.

In some countries, a smaller finger-rise washbasin (350 mm to 400 mm) is widely used, with a distance from the pan to the middle of the washbasin of 550 mm, according to Figure 40.

**26.10 Water supply**

An independent water supply (hand-held shower) shall be provided next to the toilet. An alternative such as a combination bidet and rear side pan/built-in bidet can be installed.

### 26.11 Taps

Taps should be mixer, lever or sensor operated to aid operation. The tap controls should be set no more than 300 mm from the front of the washbasin.

It is recommended that a thermostat be installed to limit the temperature of the hot water to a maximum of 40° C in order to prevent scalding.

### 26.12 Urinals

When wall hung urinals are fitted in the washroom, at least one of these should be set at a height to the bottom rim of the urinal between 600 mm and 750 mm and equipped with a vertical grab rail.

When wall hung urinals are fitted in the washroom, at least one of these should have its rim set at a height of 380 mm for wheelchair users and at least one should have its rim set at a height of 500 mm for standing users. Both should be equipped with a vertical grab rail.

This wall hung urinal should be set clear above the floor level, without any raised access platform and with a clear floor area in front of the urinal of at least 750 mm wide and 1 200 mm deep.

When wall hung urinals are fitted in the washroom, it is recommended that at least one of these have its rim set at a height of 380 mm for wheelchair users and at least one have its rim set at a height of 500 mm for standing users. When installed, both should be equipped with a vertical grab rail.

Urinals should contrast visually with the wall to which they are attached.

### 26.13 Other fittings

All other fittings, e.g. the water tank, hand dryer, hand-held shower, etc., should be set at a height between 800 mm to 1 100 mm. Coat hooks should be set at heights of 1 050 mm and 1 400 mm.

Toilet doors should be easy to open and close and comply with the general specifications indicated for doors in Clause 18. A horizontal pull handle on outward opening doors shall be provided at a height of 700 mm above the floor.

Doors should preferably open outwards.

Light switches should be fixed inside all accessible toilet cubicles or the lighting should automatically switch on when someone enters the room. Timed light switches should not be installed or used.

Needle boxes to safely dispose of needles (for example, from diabetes patients) should be provided.

If a sanitary bin is supplied, it should be reachable from the toilet seat. Sanitary bins with non-touch opening devices are preferred.

Non-touch soap dispensers are preferred.

### 26.14 Alarm

An assistance alarm, which can be reached from changing or shower seats, from the WC and by a person lying on the floor, shall be provided in all accessible toilets and accessible sanitary rooms. This alarm should be connected to an emergency help point, or where a member of staff can assist.

Visual and audible feedback should be provided to indicate that, when the alarm has been operated, the emergency assistance call has been acknowledged and action has been taken.

It should take the form of a pull cord, coloured red, with two red bangles of 50 mm diameter, one set at a height between 800 mm and 1 100 mm and the other set at 100 mm above floor level.

A reset control shall be provided for use if the alarm is activated by mistake. It shall be reachable from a wheelchair and, where relevant, from the WC, the tip-up seat in a shower or changing facility, or the bed in an accessible bedroom. The reset control shall be easy to operate and located with its bottom edge between 800 mm and 1 100 mm above floor level.

For a corner toilet room, the reset button should be above the fixed horizontal grab rail beside the toilet paper holder.

The marking of the reset control shall be both visible and tactile.

### 26.15 Emergency warning alarm

A visual emergency alarm shall be provided to alert people who are deaf or hard of hearing in the event of an emergency (see also Clause 34).

### 26.16 Shower

Showers can be used by people with different disabilities and different supporting aids, for instance, wheelchair users, ambulant disabled people, etc., using their own wheelchairs or special shower chairs.

The shower area shall have level entry and have no fixed elements that prevent front and side access.

The wet showering area should be 900 mm × 1 300 mm, with a transfer area of also 900 mm × 1 300 mm.

The floor in the shower recess shall have a gradient between 1:50 and 1:60 sloping to a floor drain. The area outside the shower recess shall have a gradient between 1:70 and 1:80 draining towards the shower recess. The transition into the shower recess shall be level without a step down or a kerb.

The waste outlet should be centrally located and be a round type outlet, not a channel type, to ensure the stability of the shower chair.

The shower should be fitted with an easily operable foldable seat that folds in an upward direction. If a foldable seat is provided, its minimum size shall be 450 mm × 450 mm, and, when folded down, have its top surface set between 400 mm and 480 mm above floor level and spaced a maximum of 40 mm from the rear wall. The fastenings for grab rails and the construction of the foldable seat shall be able to withstand a force of 1,1 kN applied at any position and in any direction.

NOTE Shower wheelchairs are sometimes used instead of shower seats.

The foldable seat shall have the following features:

- self-draining;
- slip-resistant and stable;
- foldable in an upwards direction; when folded, it shall not present a hazard and the grab rail shall be accessible from the foldable seat.

The foldable seat should have the following features:

- rounded front corners (radius 10 mm to 15 mm),
- rounded top edges (minimum radius of 2 mm to 3 mm).

The foldable seat should preferably be height adjustable.

Grab rails shall be set according to 26.7 and Figure 45. The shower area shall be fitted with at least one vertical grab rail which may hold the flexible shower head. The length of the flexible shower hose shall be a

minimum 1 200 mm. The handheld shower head should be provided between 1 000 mm and 1 800 mm above the finished floor. The shower hose fitting should be a minimum 1 300 mm above floor level.

Shower controls and folding seat shall be set according to Figure 45.

If the shower is combined with an accessible toilet, the manoeuvring areas may overlap, as shown in Figure 46.

If two or more shower recesses are provided, at least one shall have the seat on the opposite side.

Dimensions in millimetres

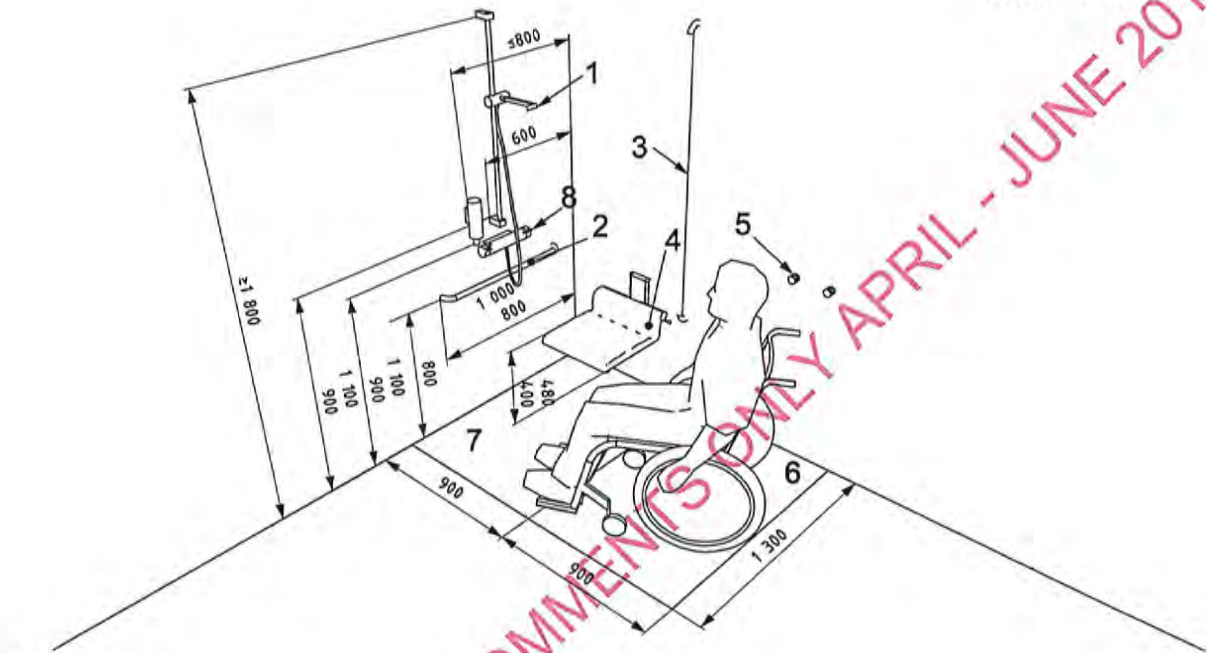

**Key**

- 1 hand-held shower head
- 2 horizontal grab rail
- 3 vertical grab rail
- 4 foldable shower seat
- 5 towel hooks
- 6 transfer area
- 7 wet showering area with gradient 1:50 – 1:60
- 8 shower controls

**Figure 45 — Example of a shower place with grab rails, adjustable shower head and folding seat**

**26.17 Individual shower room**

A free space at least 1 300 mm × 900 mm shall be provided on the clear side of the foldable seat, to allow access from a wheelchair, in addition to the manoeuvring space of 1 500 mm.

The screening of a shower recess shall be either a curtain or a door system that maintains the required circulation and manoeuvring space and does not interfere with the level entry.

A shower head support grab rail shall be fixed on the wall in the position shown in Figure 45.

A hand held detachable shower head shall be provided with a flexible hose of minimum length 1 200 mm, and it shall be able to reach within 100 mm of the shower floor.

An adjustable shower head holder shall be provided to support the shower head, and shall:

- be installed on the shower head holder support grab rail as shown in Figure 45,
- allow the graspable portion of the shower head to be positioned at various angles and heights,
- allow the graspable portion of the shower head to be located at heights between 1 000 mm and 1 800 mm above the finished floor.

The fastenings, materials and construction of the seat shall withstand a force of 1,1 kN applied at any position and in any direction.

Grab rails shall be fixed on the walls in the positions shown in Figure 45. All other devices, e.g. taps, soap holder, shall be situated in an accessible range between 900 mm to 1 100 mm.

## 26.18 Bathrooms

This subclause applies to buildings that provide bathing facilities, such as hotels, motels, hostels and sports buildings, where baths may be an alternative, or a supplement to showers (see Figures 46 to 49 as examples).

If only one accessible bedroom for people with disabilities is provided, it should be connected to an accessible shower room, rather than a bathroom, since many disabled people can only use a shower, due to their physical limitations. If more than one accessible bedroom is provided, a choice of shower or bath and a choice of right or left hand transfer to the toilet and shower or bath should be provided.

All accessible bathrooms should always contain an accessible toilet.

En suite facilities should be chosen as the preferred solution for accessible bedrooms, even when they are not provided generally for guests or residents in a hotel, motel or nursing home. If this is not possible, bathroom accommodation should be provided in close proximity to the accessible bedrooms.

The minimum overall dimensions of a bathroom intended principally for independent use, incorporating a corner toilet and a large basin, should be as shown in Figures 46, 48 and 49.

In bathrooms with a toilet that is intended for independent use, the direction of transfer to both the bath and toilet should be consistent.

When more than one bathroom for independent use incorporating a corner toilet is planned, a choice of left hand and right hand transfer layouts should be provided.

Auxiliary grab rails should be located in accordance with Figure 47.

*Exceptional considerations in existing buildings:* If the measures given above cannot be achieved due to technical reasons, the manoeuvring space at floor level may be reduced to a minimum clearance besides the toilet seat of 800 mm × 1 200 mm and a clear manoeuvring space diameter of 1 200 mm. However, it should be recognized that such a reduction may limit the use to wheelchair users with small chairs.

**NOTE** To make a bathtub accessible for users of a bath lift or hoist, a free unobstructed space under the bathtub is needed.

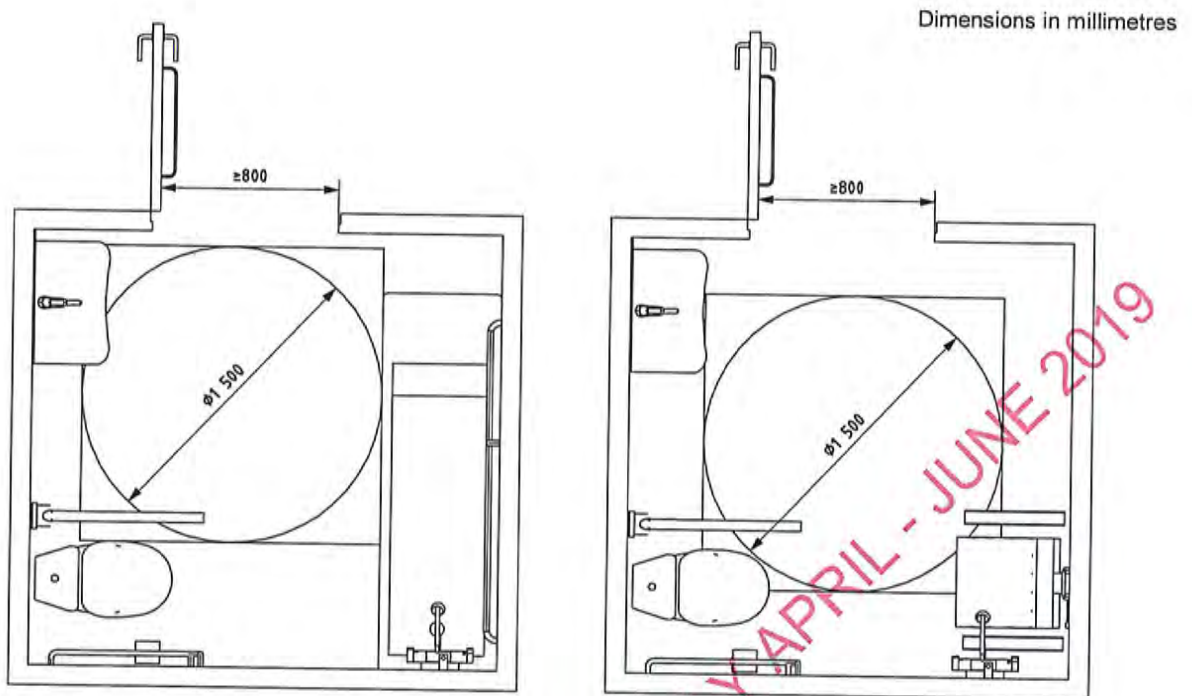

Figure 46 — Examples of a bathroom with bathtub and shower for independent use with a corner WC

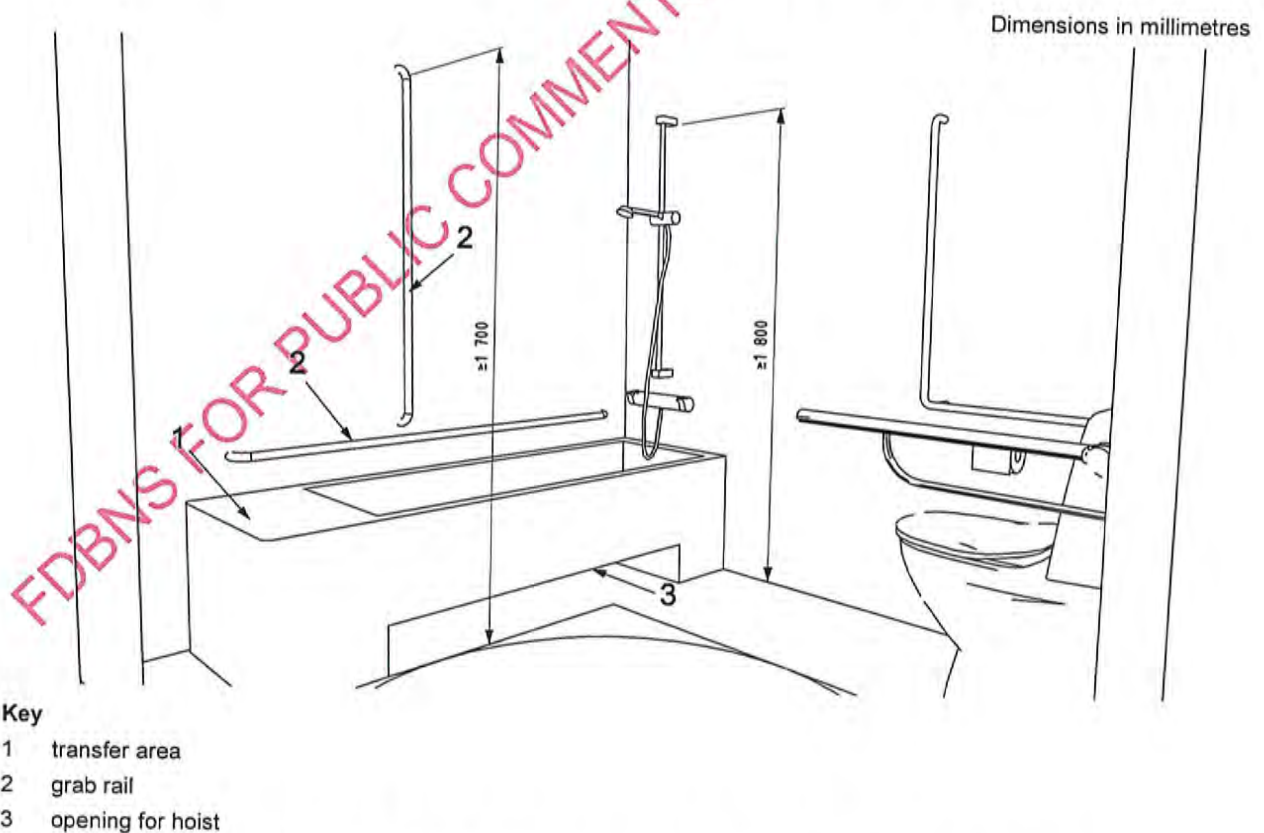
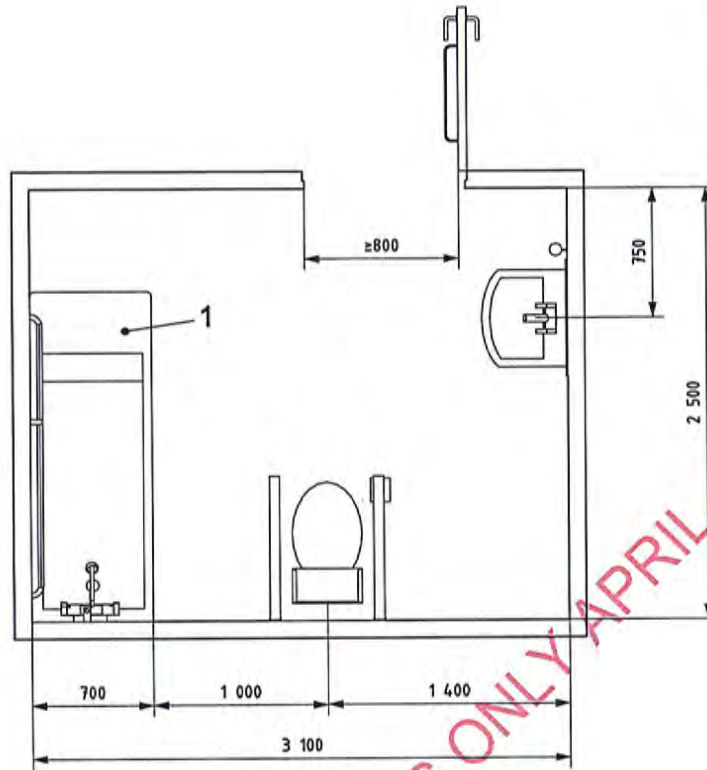

Figure 47 — Example of grab rails and transfer facilities surrounding the bathtub

Dimensions in millimetres



Key

1 transfer area

Figure 48 — Example of a bathroom for assisted use of bathtub and peninsular WC

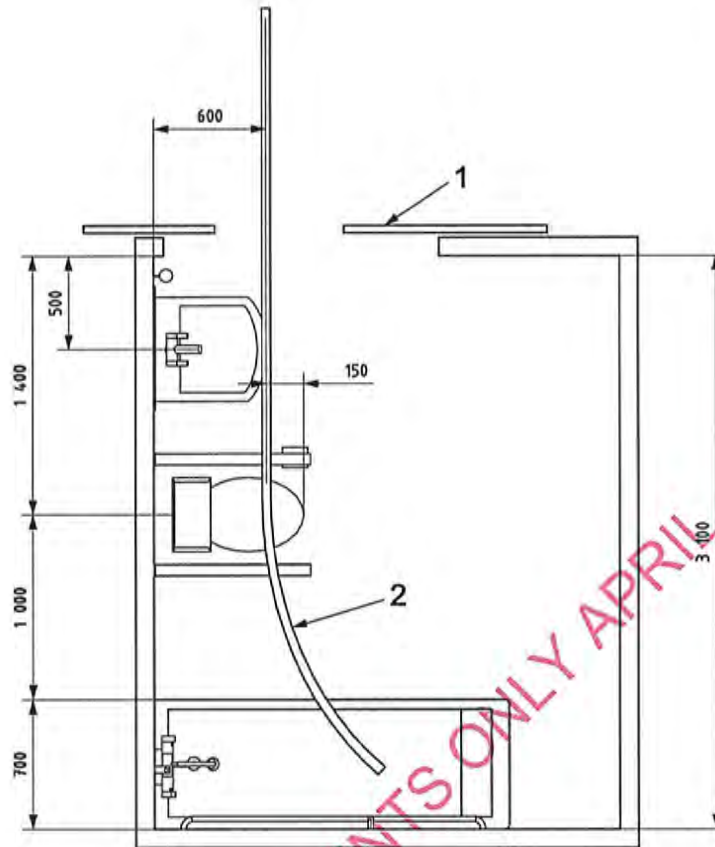

**Key**

- 1 unequal sliding doors
- 2 ceiling mounted track hoist

**Figure 49 — Example of a bathroom with a ceiling mounted tracked hoist for independent or assisted use**

## 27 Accessible bedrooms in non-domestic buildings

The access to accessible bedrooms in non-domestic buildings (i.e. hotels, guesthouses, etc.) shall comply with the requirements outlined in this International Standard, in particular with Clauses 4 and 5. The minimum number of accessible bedrooms in non-domestic buildings may be subject to national requirements or regulations. At least one accessible bedroom should be provided for every twenty standard bedrooms or fraction.

Rooms accessible for wheelchair users shall be designed for two beds. If a single bedroom accessible for wheelchair users is provided, a queensize bed is preferred, 1 500 mm width × 2 000 mm length.

Free space on at least one of the long sides of the bed shall be provided. This space should be 1 500 mm, and shall not be less than 1 200 mm. At the foot of the bed, at least 1 200 mm is required (see Figures 50 and 51).

An open space of at least 300 mm between the floor and the mattress should be provided to facilitate the use of a hoist.

Sufficient clear manoeuvring space is needed to gain access to facilities, including the shower.

There should be a bench for luggage at a height between 450 mm to 650 mm.

The minimum height of a bed shall be between 450 mm to 500 mm, when it is compressed under a 90 kg weight.

For communication for people with hearing, vision and cognitive limitations, see Clause 32 and Annex B.

Visual and audible alarm systems shall be accessible to warn people with visual and hearing impairments; consider Clause 34 for fire emergency warnings.

Consider Figures 46 to 49 for details of an accessible bathroom. Manoeuvring space of a minimum 1 500 mm × 1 500 mm allows front facing or 45° oblique transfers by wheelchair users.

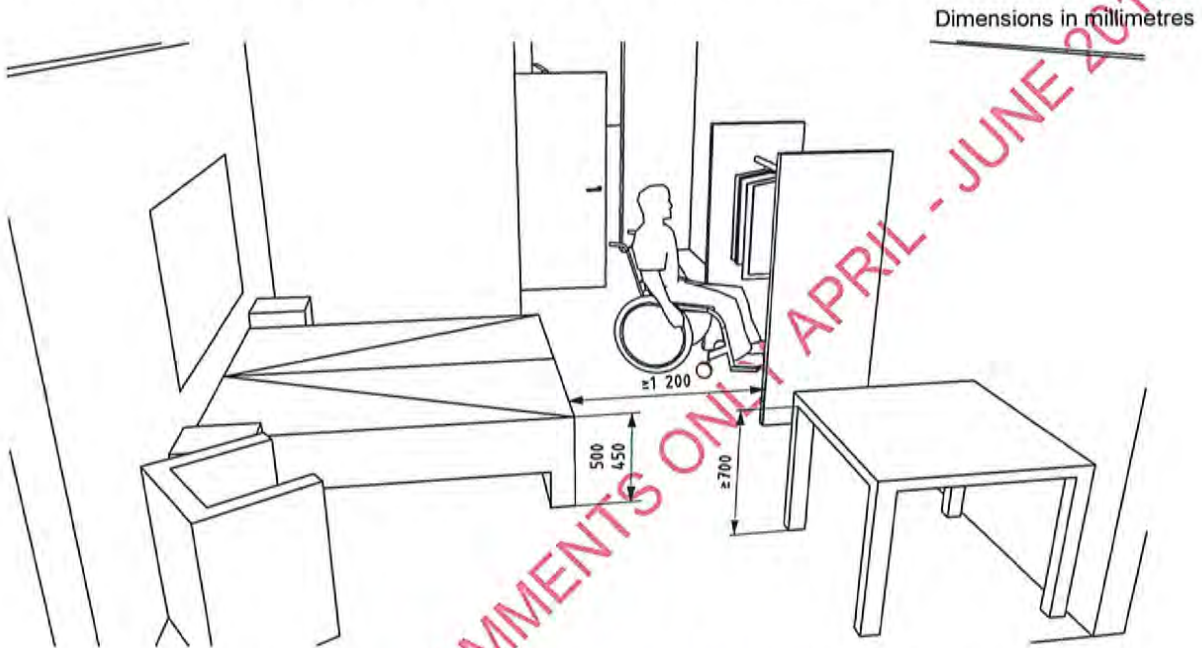
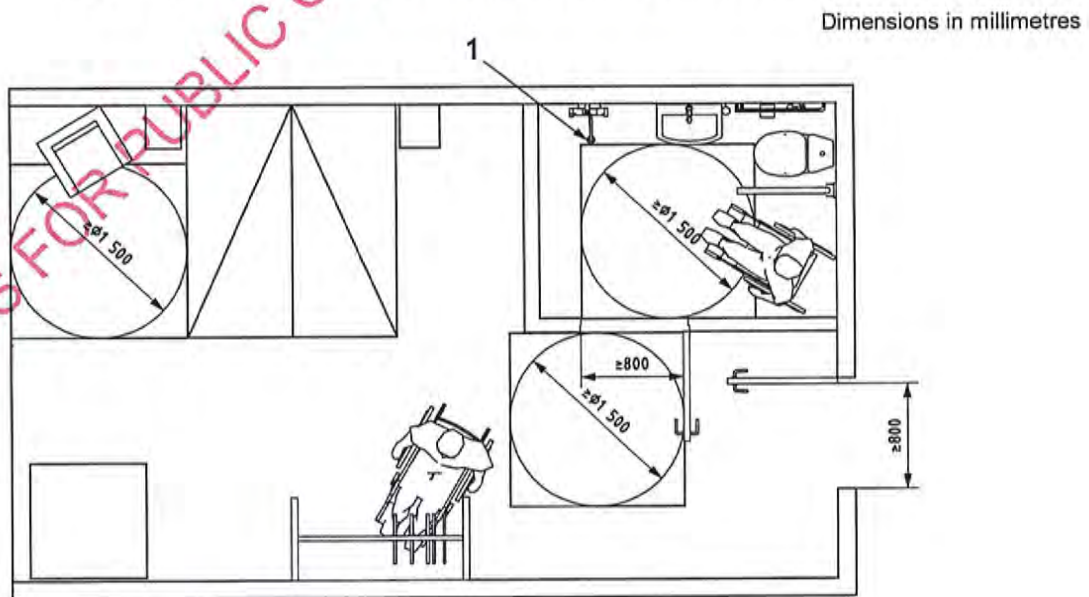

Figure 50 — Example of space allowances for accessible bedroom



Key  
1 shower area

Figure 51 — Example of space allowances for accessible bedroom and bathroom

## 28 Kitchen areas

Kitchen areas shall take into account general design considerations in Clause 4, manoeuvring space (see B.6.1 and B.6.2), slip resistant walking surface and accessible height of controls and devices (see 36.2).

Essential kitchen appliances (oven, refrigerator, etc.) should be usable by persons both standing and sitting in a wheelchair, and a worktop should be located beside all appliances.

A section of the shelves should be within reaching distance for a wheelchair user, between 500 mm and 1 100 mm above floor surface.

The sink taps should be reachable and easy to operate with one hand. The sink should be reachable for a wheelchair user and it is recommended to provide adequate space under the sink according to the user's needs or to provide adequate space beside the sink. If a knee recess is provided under a sink, its underside should be insulated.

## 29 Storage areas

The minimum manoeuvring space (see B.6.1) and reachability for wheelchair users (see B.6.3) should be taken into consideration when designing and constructing a storage area.

Part of the shelves should be within reaching distance for a wheelchair user, between 500 mm and 1 100 mm above the floor.

If a door is provided, it should open outwards.

## 30 Facilities for guide dogs and other assistance dogs

### 30.1 General

In theatre and spectator facilities (this also applies to waiting rooms/other seating areas) it is recommended that some seats should be located so that a guide or assistance dog can accompany its owner and rest in front of, or under the seat.

### 30.2 Relief facilities for guide dogs and assistance dogs

The need for relief facilities for guide and assistance dogs should be decided at a national level.

A relief facility for guide and assistance dogs should be provided near large buildings, such as shopping centres, leisure or entertainment complexes and transport or other facilities, and any building where a guide or assistance dog owner is employed.

A secure area should be provided close to the building for use as a dog relief facility. The dog relief area should be at least 3 m × 4 m with a 1 200 mm high secure fence. The entrance gate to the enclosed area should have an easy to operate and secure catch. The surface area should be concrete with a smooth finish to assist in cleaning and a slight fall, of 3,5 %, to assist in drainage. It would be good practice to provide a waste bin and a supply of plastic bags, close to the entrance. An accessible sign saying "For assistance dogs only" should be displayed. The area should be cleaned regularly and well maintained.

## 31 Floor and wall surfaces

Floor coverings shall be firm and slip-resistant in both dry and wet conditions.

Floor and wall surfaces should be anti-glare. Confusing reflections caused by the inappropriate use of floor and wall finishes and the location of mirrors and glazing should be avoided.

For visual contrast see Clause 35.

The surfaces should contribute to an acoustic environment that helps in orientation; see also Clauses 32 and 33.

## 32 Acoustic environment

### 32.1 General

The acoustic environment in a building should be suitable for its intended function for all building users. This includes all hearing people especially the hard of hearing. For deaf and hard of hearing people, good lighting is essential to understand the sign language interpreter and/or optical information devices.

Many people with some degree of hearing loss have assistive devices to amplify sound, such as hearing aids or cochlear implants.

However, if the acoustic environment is not supportive of these devices, they do not work effectively. In addition, many people who have a mild or temporary hearing loss and do not have assistive devices may not be able to access information or communicate effectively.

Most people with hearing loss and people without hearing loss rely on sight to lip read or interpret facial expressions; therefore where the acoustic environment is regarded as important, suitable lighting, colour and visual contrast should be considered to benefit all building users.

Information normally conveyed in visual form may not be accessible to people who are blind or partially sighted. This information should also be conveyed audibly; the clarity (speech transmission index) of this information is affected by the acoustic environment.

The following design considerations should be taken into account to maximize the functionality of the acoustic environment, and to support the use of assistive devices.

### 32.2 Acoustic requirements

People with hearing impairments have particular difficulty in making out sounds and words in noisy environments. Adequate sound insulation should minimize noise from both outside and inside the building. Noise can often be "mitigated", for example, by introducing a buffer zone between a meeting area and extraneous noise, or partitioning a restaurant.

The acoustics in a room are essentially connected with its location in the building and with the acoustic insulation of the building elements. The distribution of noise within the room itself and from exterior sources depends on the sound absorption of the surrounding surfaces and furnishing of the room. The calculation of acoustic absorption is significant in rooms where acoustic quality is important and also where noise reduction is required.

Good acoustics shall be achieved by optimizing the reverberation time, by considering the use/purpose of the room and by ensuring a low background noise level. The optimum reverberation time of a room should be determined having regard to the volume and the intended purpose of the room.

The geometry and shape of the room, as well as the distribution of sound absorbing and reflecting surfaces, are important. Surfaces that absorb sound should be carefully selected, as well as surfaces that reflect it. To develop an effective acoustic environment, sound absorbent surfaces can be used on floors and ceilings.

The optimum reverberation times for communication, speech only or music performance are different and depend on the size and shape of the room.

NOTE Requirements for reverberation time are given in some National Standards, such as DIN 18041.

### 32.3 Hearing enhancement systems

A hearing enhancement system fitted at an information point can significantly assist communication for a person with a hearing impairment who uses a personal hearing aid, or has a cochlear implant. Hearing aids or cochlear implants may have a Telecoil (T-switch) which allows the listener to receive the sound signal directly.

NOTE Hearing enhancement systems amplify audible communication and can be helpful to people who have a hearing impairment. They include a direct wire system, an inductive loop system, an infrared system, or a radio frequency system. All of these systems transmit a signal. Special-purpose receivers are required for infrared and radio frequency systems, while hearing aids equipped with a T-switch are capable of receiving the signal from an induction loop system. Receivers can be equipped to be compatible with hearing aids.

Hearing enhancement systems, for example induction loops and infrared signal transmitting systems, shall be provided in conference and meeting areas.

All seats, including the front scene, should be covered by hearing enhancement systems like induction loops. Portable hearing enhancement systems can be an alternative.

Induction loops should comply with the technical values given in IEC 60118-4 (see Figure 52).

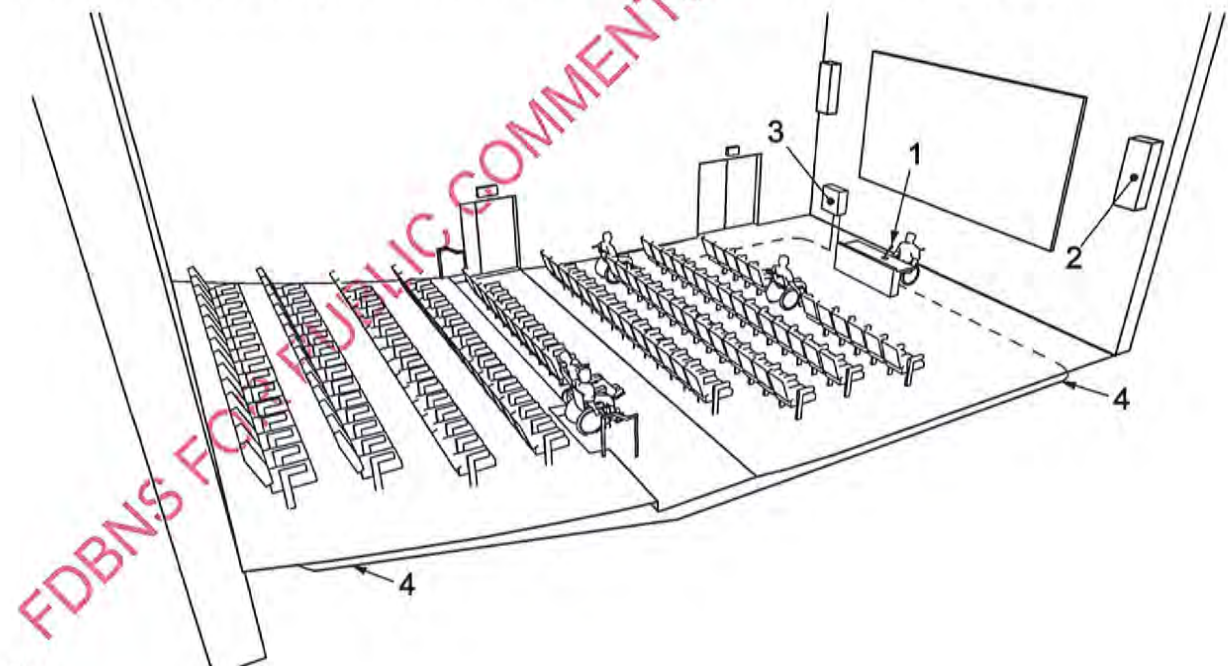

**Key**

- 1 microphone
- 2 loudspeakers
- 3 induction loop amplifier
- 4 induction loop

**Figure 52 — Example of induction loop system in conference room**

## 33 Lighting

### 33.1 General

The planning of artificial lighting should be co-ordinated with the planning of natural lighting, the choice of surfaces and colours. Lighting can be used to accentuate interior colour, tone and texture schemes, and to facilitate orientation (also see Clause 39). The lighting should not lead to glare or excessive contrast.

### 33.2 External lighting

The routes to and around a building shall have sufficient artificial lighting to facilitate awareness of changes of level or gradient. The positioning of lights should not cause glare, reflection or shadows. Ramps, entrances, steps, signage, etc., should be well lit artificially, with an illuminance of at least 100 lux.

### 33.3 Natural lighting

It should be possible to shade windows from bright light. For the location of windows see 33.4 to 33.9 and 18.3.3.

### 33.4 Artificial lighting

Lighting should provide visual conditions consistent with the visual task, orientation and safety. Key factors are:

- level of illumination of horizontal and vertical surfaces,
- limitation of glare from a light source or reflections,
- uniformity and luminance distribution,
- direction of lighting and shading,
- colour rendering.

Artificial lighting should give good colour rendering. Light sources with a colour rendering index Ra are recommended.

NOTE 1 For safety colours see ISO 3864-1.

NOTE 2 Good artificial lighting where needed is crucial for everyone, ensuring that vision impaired people are able to use buildings safely and conveniently, and that people with hearing impairments are able to lip read.

### 33.5 Lighting to facilitate wayfinding

Lighting should facilitate wayfinding: building elements should be marked by increased illumination. The lighting in critical locations such as entrances, corridors, stairs, changes of level and workstations should facilitate their identification (see also 33.3).

Time dependent switch devices shall have a progressive switch off to reach the next switch. An automatic switch on detection system shall cover the complete surface of ramps and stairs. Lighting shall provide sufficient time necessary for users to travel safely along ramps.

Lighting which switches off when people are still on ramps or stairs should be avoided.

NOTE Ramps and stairs are the most hazardous places for falls.

### 33.6 Controllable and adjustable lighting

All lighting, including natural light, should be controllable to avoid glare.

Artificial lighting may be adjustable to suit individual needs.

### 33.7 Light levels in different areas

Good light levels should be provided in hazardous areas such as stairs or changes in levels along a route, around doors and at communication or information systems.

A minimum light level should be provided according to the visual task as shown in Table 4.

Table 4 — Minimum light level in different areas

Different areas	E <sub>min</sub> [lux]
Horizontal surfaces indoors	100
Stairs, ramps, escalators, moving walks	150 – 200
Habitable spaces	300 – 500
Visual task with small details or low contrast	1 000

### 33.8 Lighting in auditoriums

Lighting conditions that support lip reading and sign language should be provided. The environment should be designed to avoid reflection and glare, and it should be possible to adjust both natural and artificial light.

### 33.9 Glare and shadows

Lighting should not produce glare. Glare and shadows can be avoided by:

- shielding or shading light sources,
- use of indirect lighting,
- appropriate location of light source in relation to the direction of vision and to the object that is to be observed,
- uplighters, with light sources at floor or low level, should not be used,
- avoidance of windows at the end of corridors,
- avoidance of light sources against dark surfaces by choosing light colours for ceilings or walls,
- avoidance of abrupt transitions from light to dark spaces. Indoor and outdoor lighting around the doorway should be suitably adjusted to prevent dazzle when entering or leaving the building.

The Unified Glare Rate (UGRL) should not exceed 25 for circulation areas and 22 for habitable rooms.

NOTE 1 For determination of UGRL, see methodology defined by CIE.

NOTE 2 Due to the increase of optical scatter in the eye, the effects of glare are exacerbated for elderly people and for individuals with some types of vision impairments (e.g. cataracts, corneal edema, and vitreous opacities). Glare can cause discomfort and interfere with task performance by decreasing the perceived contrast in visual displays (i.e. disability glare).

## 34 Fire emergency warning systems, signals and information

### 34.1 General

In all building types, a reliable and effective fire warning system is essential.

Nowadays, available technologies enable warnings to be communicated simultaneously by sounder, light strobe, voice message and individual tactile sensation by vibration.

Alarm systems should be designed to accommodate people with hearing impairments. Visual strobe alarms should be provided, particularly in isolated areas (bathrooms, meeting rooms) and noisy areas.

Room layouts, lighting levels and furniture arrangements shall be considered to ensure that these alarms are visible. A strobe frequency of 0,5 Hz – 4 Hz minimizes the risk of triggering a reaction from a person with epilepsy. Care should be taken to ensure that overlapping strobes do not combine to result in a higher frequency of flashing. Vibrating devices such as pagers or mobile phones can be integrated with alarm systems to provide an individual alarm.

### 34.2 Light warning signals

Light strobes/beacons should be clearly visible. Light strobes should be located in washrooms and in other locations within buildings where people are apt to be alone and also in noisy environments.

A larger number of strobes/beacons with low output should be specified – never a small number of strobes/beacons with high output as these produce glare causing confusion and disorientation among building users. Adapt light output of strobes/beacons to suit the use of particular areas.

For light strobes/beacons, a slow rate of flash should be ensured (e.g. once every two seconds) in order to avoid epileptic seizures. Most importantly, the flash of one strobe/beacon should be synchronized with the flashes of all other light strobes/beacons in view.

### 34.3 Acoustic warning systems

A larger number of sounders between 85 dB to 95 dB with low output should be specified – never a small number of sounders with high output which only leads to confusion and disorientation among building users.

Vocal messages should be short and should contain appropriate warning information which is easily assimilated. The speaker should be distinct and easy to understand. In today's multi-cultural built environment, messages should be given in at least two different languages.

NOTE Children under ten years of age, who are asleep, are more difficult to wake than adults.

## 35 Visual contrast

### 35.1 General

In order to facilitate orientation and to ensure safe use of an environment, adjacent surfaces, information and potential hazards shall provide a discernible visual contrast.

A minimum difference in LRV shall be provided in relation to the visual task (see Table 5). Additionally, one of the two surfaces should have an LRV value of minimum 30 points for door furniture, 40 points for large area surfaces and 70 points for potential hazards and text information.

The minimum difference in the LRV shall be achieved and maintained throughout the life of the building elements. Deterioration and maintenance shall be considered at installation.



For lighting conditions lower than specified in this International Standard, the difference in LRVs should be higher. Refer to published recommended levels of illumination and to 33.4 for extra illumination to mark important areas or details.

NOTE 1 The LRV, sometimes also called the luminance reflectance value, or CIE Y value, is expressed on a scale of 0 – 100, with a value of 0 points for pure black and a value of 100 points for pure white.

NOTE 2 The perception of visual contrast increases with better lighting conditions.

NOTE 3 Reflections and glare from shiny surfaces can reduce visual contrast and can confuse people with vision impairments.

For door hardware (i.e. the elements and components to facilitate opening and closing doors) a difference in LRV between the product and its background of at least 15 points and a minimum light reflectance value of 30 points for one of the two surfaces is acceptable.



NOTE 4 Door hardware is normally positioned at the same height on a door and is either on the left or right side. This makes the location of door hardware easier than other features. In addition, the three-dimensional features of door hardware create shadows and bright spots, which further enhance their location.

Floor patterns should have a visual contrast of less than 20 points difference on the LRV scale.

NOTE 5 Highly contrasted floor patterns can be perceived as differences in floor level, which may confuse people with vision impairments or cognition capacity. Highly contrasted floor patterns may trigger an attack of vertigo.

Methods for the determination of LRV and visual contrast are outlined in B.7.2.

**Table 5 — Minimum difference in LRV according to the visual task**

Visual task	Difference on the LRV scale	Approximate examples of contrasting colours
Large surface areas (i.e. walls, floors, doors, ceiling), elements and components to facilitate orientation (i.e. handrails, switches and controls, tactile walking surface indicators, and visual indicators on glazed areas)	≥ 30 points	
Potential hazards and self contrasting markings (i.e. visual indicator on steps) and text information (i.e. signage)	≥ 60 points	

### 35.2 Choice of colours and patterns

Different colours should be used for identification of doors, different storeys or departments in a building to aid persons with impaired cognitive ability. The colours used to facilitate orientation shall also provide minimum difference in LRV according to 35.1. Combinations of red tones and green tones should be avoided.

Different storeys should be marked with clearly defined large numbers relating to the floor (i.e. “2” for the second floor, and so on) both in the stairwells to assist those evacuating and at the lift and stair lobbies on each level.

NOTE Colour coding floors may not be practical from a long term maintenance perspective.

## 36 Equipment, controls and switches

### 36.1 General

The design and construction of operating controls and devices should be such as to enable them to be operated safely and independently by everybody.

Operating controls and devices include, but are not limited to:

- door handles and locks;
- lever, mixer or cross-head taps;
- activation devices;
- window openers and locks;
- electric outlets and switches.

Controls should be easy to use, e.g. by hands-free operation or by using the elbow. Minimum manual effort should be required, as for opening and closing doors.

All switches and controls should be easy to understand without requiring specialist knowledge.

Sufficient lighting of the control devices and all relevant information should be provided (see 40.6, 40.7 and 40.8).

Round or oval type door knobs are not suitable for people with mobility impairment, for people of small stature or less strength, and for children.

The use of photoluminescent pictogram signs shall be provided where appropriate.

### 36.2 Location, heights and distances

Devices, controls, etc., shall be installed at an accessible height for reaching and operating, between 800 mm and 1 100 mm above floor level and shall be located a minimum of 600 mm from any internal corner, preferably 700 mm. For detailed requirements see also 40.3 and 40.8.

**NOTE** As an exception, electrical wall socket outlets, telephone points and TV sockets could be located at a minimum height of 400 mm above floor level.

Control devices (radiator valves, fuse boxes, switches, push-buttons, intercoms, etc.) shall be installed between 800 mm and 1 100 mm above floor level, and they shall be located a minimum of 600 mm from any internal corner.

Requirements and recommendations on lifts landing controls and car controls can be found in 15.3 and 15.4.

Control devices combined with text or figures should be positioned with the text and figures or the whole control device placed at the angle of approximately 45 ° to the wall so that they are easier to read and operate, e.g. a panel in an elevator.

Control devices placed on a horizontal surface should be placed at a height between 800 mm and 900 mm and within 300 mm from the edge of the surface.

Socket outlets, including those for telephone or TV, should be located not less than 400 mm but not more than 1 000 mm from the floor.

Reading meters should be located between 1 200 mm and 1 400 mm from the floor.

Heights of switches, socket outlets, reading controls and controls on a horizontal surface are illustrated in Figure 53.

Safety regulations related to electricity should be consulted in every country.

Dimensions in millimetres

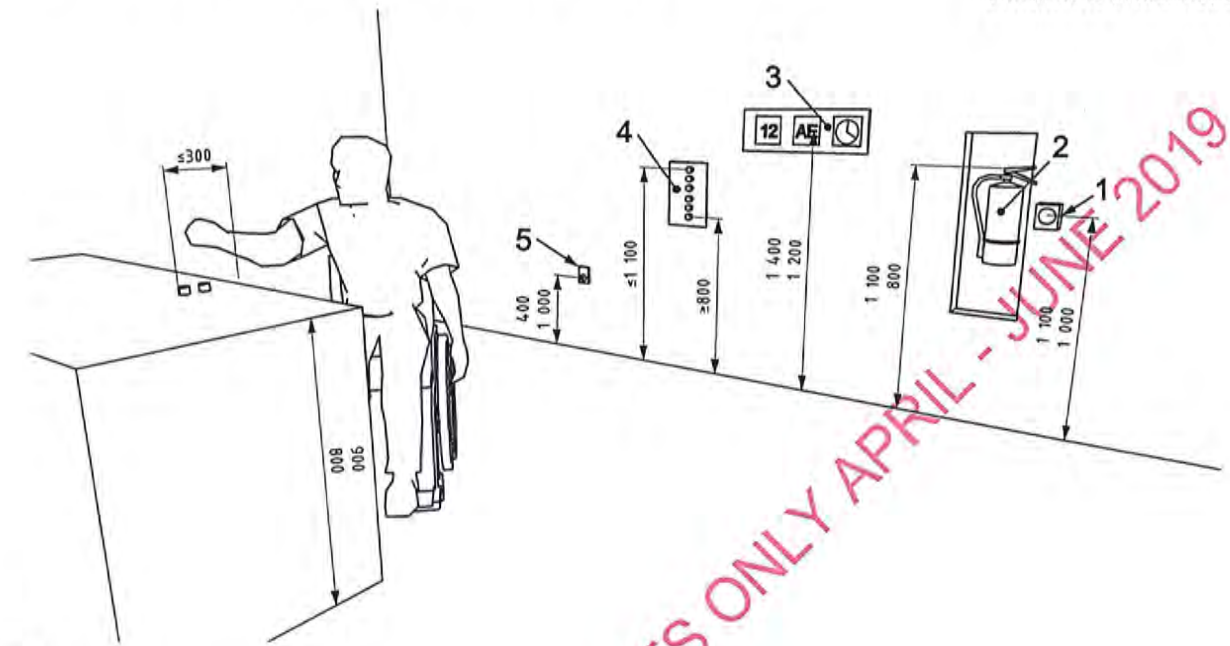

**Key**

- 1 fire alarm, call point
- 2 fire extinguisher
- 3 meter indicators
- 4 control devices
- 5 socket outlets

**Figure 53 — Heights of switches, socket outlets, reading controls and controls on a horizontal surface**

Door handles should be placed according to Figure 54. In this figure, the figure on the left shows the height of a handle for pushing or pulling the door, the middle figure shows a vertical door handle, and the figure on the right shows an example of a pull rail that might allow a wheelchair user to close the door behind him, for example, in a toilet.

If fire and safety related, all controls should be intuitive and obvious to use. A fire extinguisher should have a maximum weight of 5 kg or 6 litres or even less.

Fire alarm calls should be located between 1 000 mm and 1 100 mm above floor level.

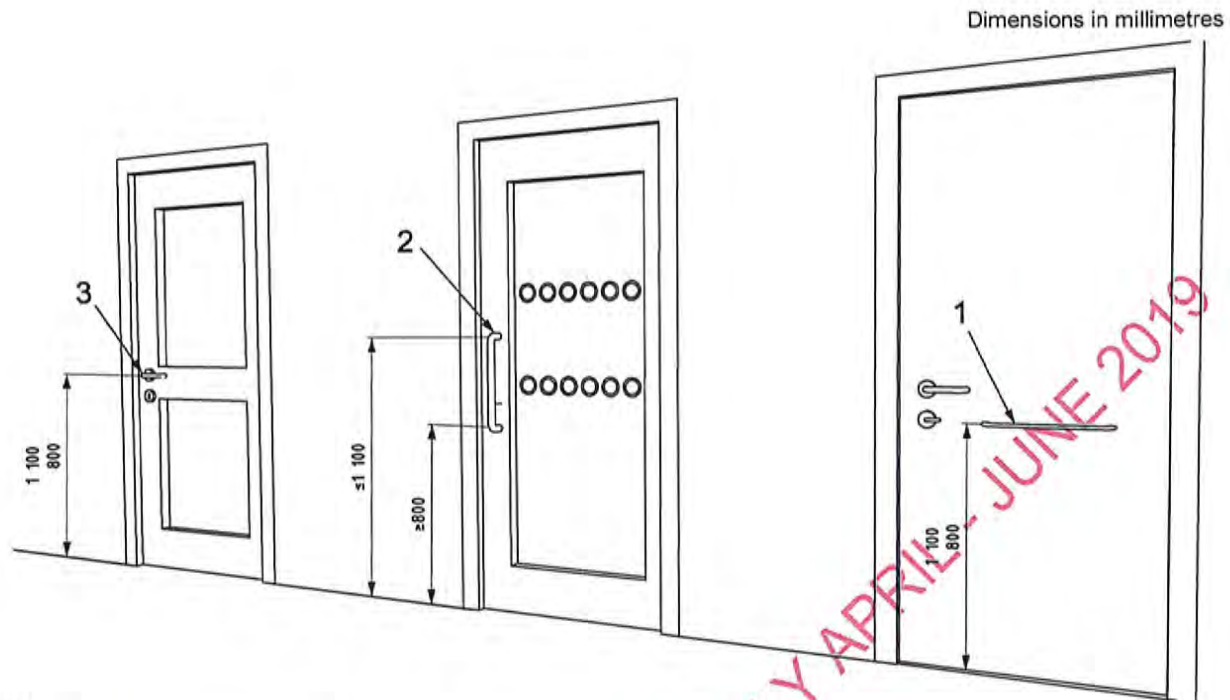

**Key**

- 1 horizontal pull rail, toilet room door
- 2 vertical handle
- 3 lever type handle

**Figure 54 — Door handle types and heights**

**36.3 Location of controls from walls, corners and opening doors**

The minimum distance of the centre of switches and devices to control doors or windows, etc., shall be 600 mm from any internal corner or any projecting element (see Figure 55) and the recommended distance is 700 mm.

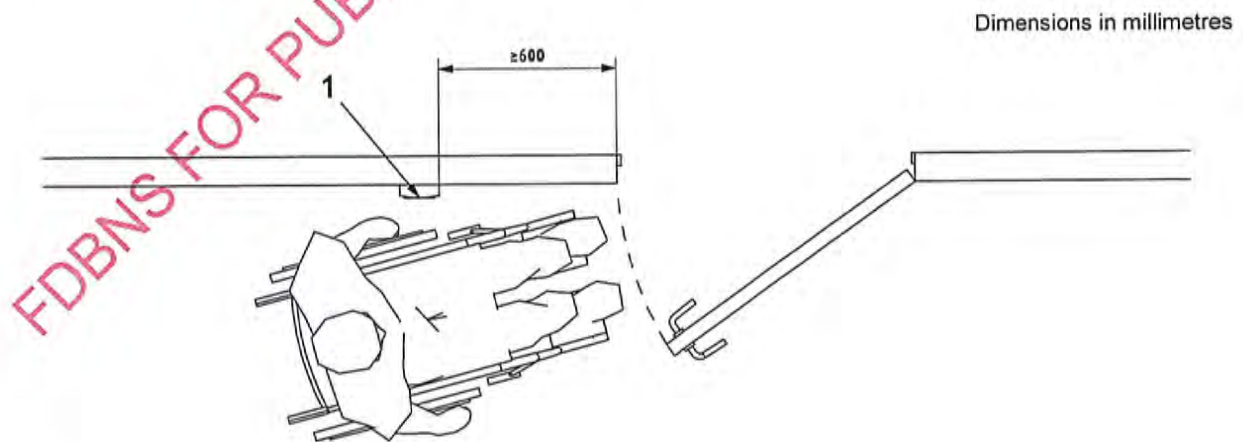

**Key**

- 1 door control, access control

**Figure 55 — Position of door and access controls**

Controls for powered door openers to hinged doors should be located so that the doors do not interfere with wheelchairs, canes, walking aids, etc. Controls for powered door openers to hinged doors should be located a minimum of 1 000 mm from the swing of the arc of the door so that the door is clear of people in wheelchairs, scooters or other assistive devices (see Figure 56). The opening time shall be sufficient for a person using wheelchair or assisting devices to pass through the door safely before it closes.

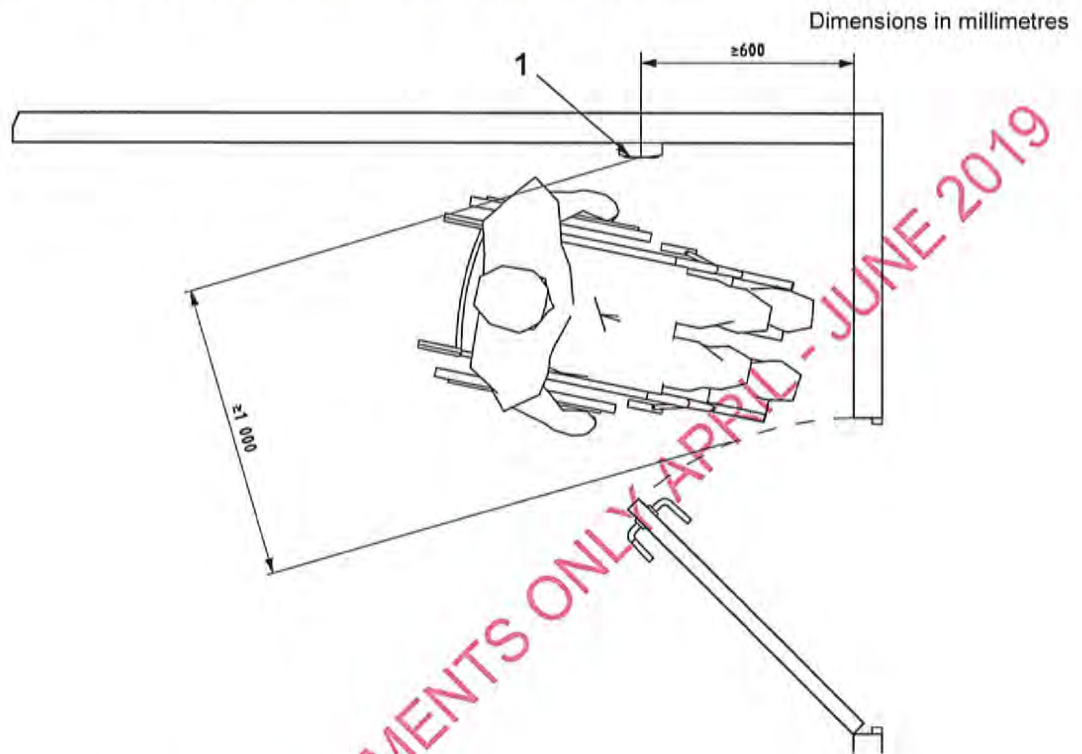

**Key**

1 door control, access control

**Figure 56 — Distance of controls for powered door openers**

### 36.4 Operation

To help people with reduced dexterity or impaired vision, electrical switches should have large push plates.

Grab bars and door or window handles should be at least 80 mm long.

Lever handles should be between 19 mm and 25 mm in diameter; "D-Lever" handles are preferred (see Figure 57).

A vertical bar for sliding doors should be 30 mm to 50 mm in diameter. The clearance between the bar and the wall should be 45 mm to 65 mm.

The backset of a latch/lock should be a minimum of 30 mm. Other door furniture should be 30 mm from the door edge.

Suitable clearance should be provided between adjacent fixtures and fittings to prevent accidental operation.

Operating force on control buttons and push plates should be 2,5 N to 5,0 N.

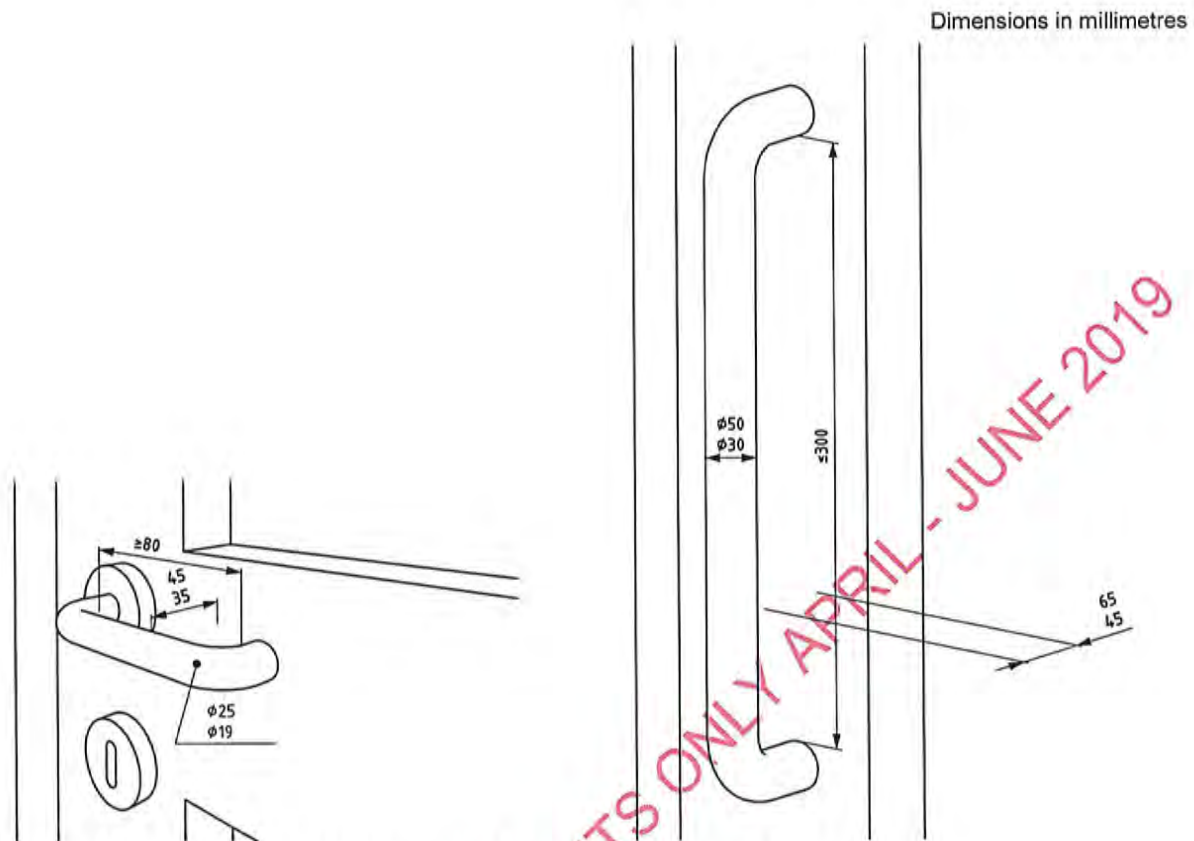

Figure 57 — Examples of D-lever and vertical door handles

### 36.5 Identification

Buttons and devices should be identified by visual contrast.

Information should be in raised tactile and Braille signage.

All important controls should have an integral Braille indication.

### 36.6 Usability

Control devices for different functions should be different. Control devices for similar functions should have a similar design and activation mechanism and be the same for identical functions throughout the facility.

### 36.7 Telephones

Telephones shall be on a clear accessible route with approach from the front or the side (see B.6.1). All information should be provided in at least two of visual, oral and tactile forms. The telephone keypad shall have a tactile point on the number five.

Public telephones should be located beside the access route and should be easily detected by people with vision impairments.

Control devices shall be at a maximum height of 1 100 mm. A clear space underneath shall be provided for wheelchair-user's knees (see Figure 58). At least one telephone in any group should fulfil these conditions and be equipped with a magnetic field and text display.

Side protection shall be considered according to 7.14 and 7.15.

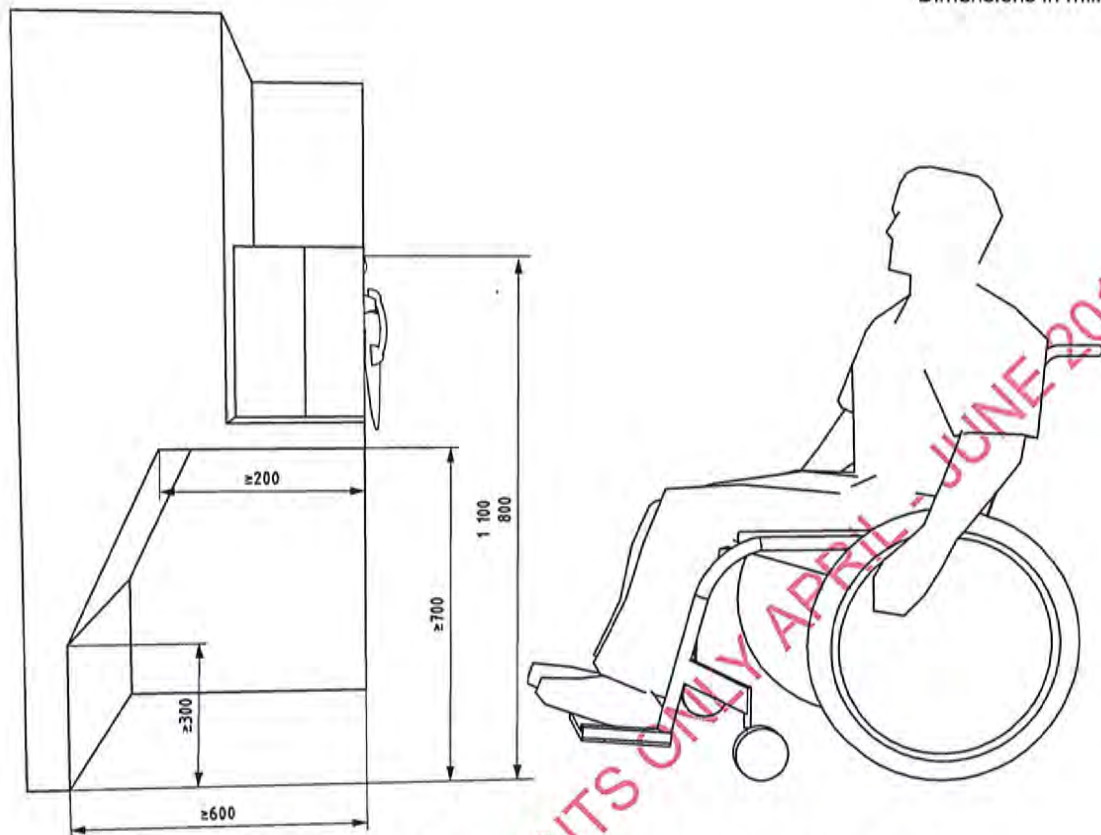

Figure 58 — Height of telephone controls for wheelchair users

### 36.8 Card access, dispensing machines and automatic teller machines (ATMs), etc.

Machines for dispensing money, tickets or small goods should be accessible and should be located on an accessible level. The approach to dispensers should be clear and unobstructed, at least 900 mm wide. A knee space a minimum of 700 mm in height and a minimum 600 mm in depth and 900 mm in width should be provided to ease access for wheelchair users (see Figure 59).

Touch screen ticket dispensers at train/bus stations, etc., should not be the only type of ticket dispenser, as they are inaccessible to people with impaired vision.

The clear area immediately in front of the machine should be at least 1 500 mm × 1 500 mm, to allow a wheelchair user to approach the controls sideways, and to turn around after use and to provide some privacy.

The operation of the machine should be easy to understand.

Glare from sun, artificial lighting and street lighting on the screen should be avoided.

Card access shall:

- a) have a slot
  - located at a height of between 800 mm to 1 100 mm above the floor, preferably between 800 mm and 900 mm,
  - with its edge bevelled, and
  - colour-contrasted with the surrounding surface;

- b) include tactile graphic symbols on the surrounding surface that
  - represent the card,
  - identify the orientation of the card insertion;
- c) have both audible (beep) and visual (light) signals to indicate that access has been granted.

The keypad shall:

- a) be located at a height between 800 mm to 1 100 mm from the floor,
- b) be colour-contrasted with the background,
- c) have characters that are colour-contrasted with the keys,
- d) if numeric, be of a type whose buttons have a raised dot on number five which:
  - is  $0,7 \pm 0,1$  mm high, and
  - has a base 1,5 mm in diameter, and
- e) have both audible (beep) and visual (light) signals to indicate that access has been granted.

The keys should be readable from both a standing and a seated position.

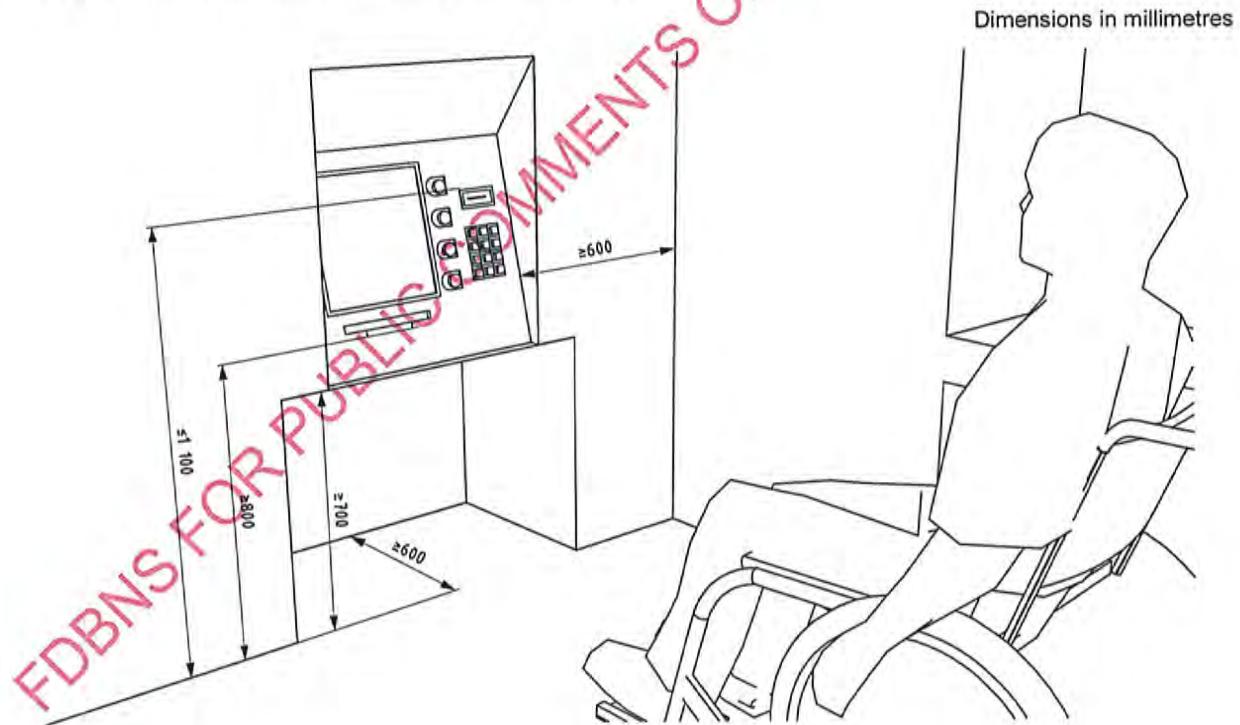

Figure 59 — Example of a vending machine



## 36.9 Security access systems

Security access systems shall be designed in accordance with B.6 to meet the needs of everyone. This includes the requirements for manoeuvring space and for controls which can be reached comfortably. See 36.8 for requirements relating to card access and keypads.

Accessible security systems are available and should be utilized. Security access systems should be usable by everyone. Biometric systems (e.g. retinal or palm scanners) cannot accommodate all users.

## 36.10 Drinking fountains

Drinking fountains should be provided according to 36.1 and 36.2 at heights suitable for both standing and seated users.

Where only one is provided, it shall be at a height of 700 mm above floor level.

Controls shall be centrally positioned at the front of the unit or, if at the side, on both sides, not more than 180 mm from the front. Controls shall be operable with one hand with an operating force of not more than 19,5 N.

## 36.11 Refuse bins

Refuse bins should be fully accessible and easy to use for everybody.

## 37 Furnishing

### 37.1 General

Seating facilities should be provided in public buildings to provide people with a place to wait and to rest (see 19.6 for requirements on assistance dogs).

The location of seats (including reserved areas for wheelchairs) should not disturb the general circulation.

Seats should be designed with armrests to facilitate sitting down and standing up. The seats should also have back rests (see Figure 60).

See also Clause 30 regarding facilities for guide dogs and other assistance dogs.

### 37.2 Seating in waiting areas

A range of different types of seating should be provided complying with (see Figure 60):

- seat height 400 mm to 450 mm,
- back support height 750 mm to 790 mm,
- seat depth 400 mm to 450 mm,
- angle of seat to backrest 100° to 105°,
- armrest height 220 mm to 300 mm above seat,
- armrest set back from front of seat  $\leq$  75 mm,
- a minimum 150 mm set back under the seat for feet when standing up.

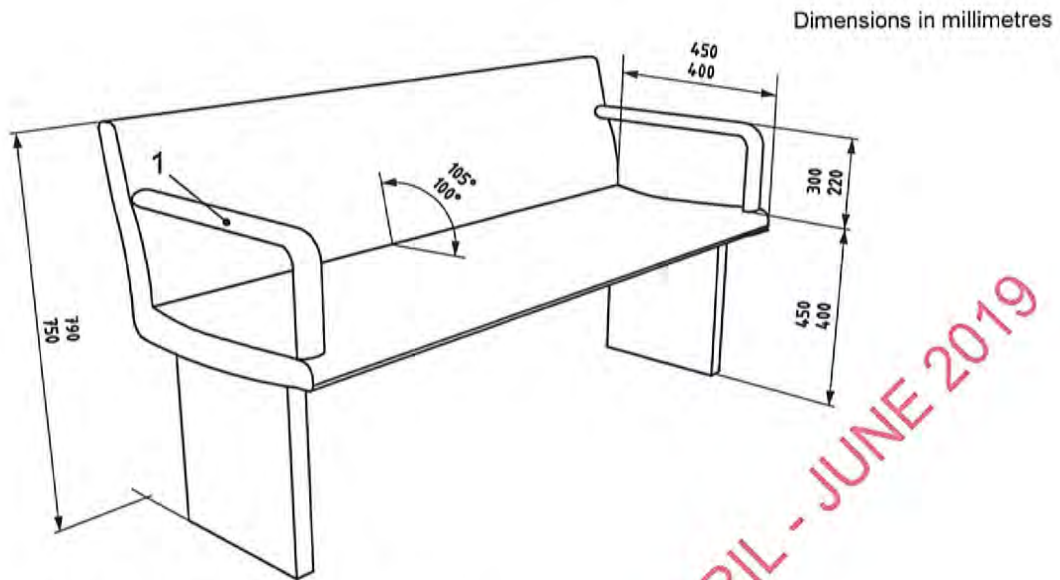

**Key**

- 1 armrests omitted on some benches to allow lateral transfer

**Figure 60 — Example of a bench with armrests and back support**

**37.3 Seating at desks, tables, etc.**

To allow a frontal approach with a wheelchair to a table, desk, counter, telephone, etc., an unobstructed space shall be provided with a minimum free height of 700 mm, minimum free depth of 600 mm and minimum width of 900 mm to accommodate knees underneath. For footrests, a minimum height of 300 mm is required (see Figure 61).

If tables with fixed seats are used, there shall be a place for at least one person in a wheelchair at the table.

Dimensions in millimetres

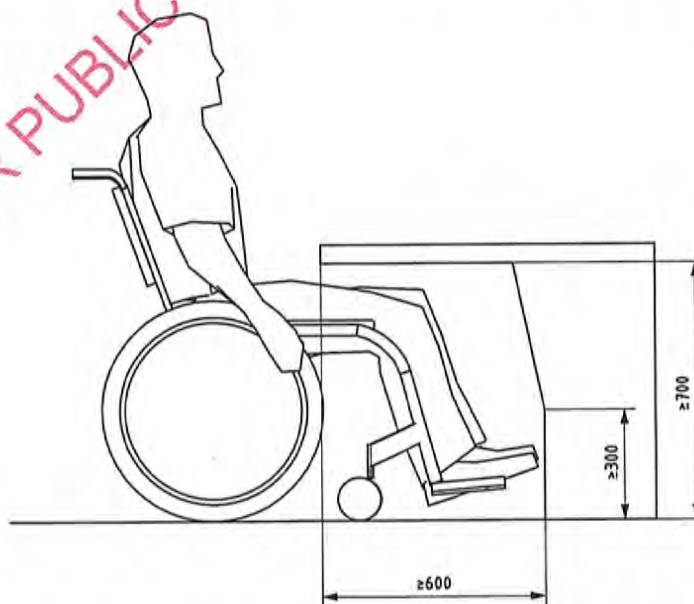

**Figure 61 — Table and desk height for wheelchair users**

## 38 Fire safety, protection and evacuation for all

### 38.1 Fire engineering design objectives

In order to adequately protect people with activity limitations and/or people with impaired senses in a fire emergency, e.g. frail older people, people with disabilities, children, and women in the later stages of pregnancy, fire engineering design objectives should be developed. The two critical design objectives are:

- a) Protect people from fire in any of the following locations, when relevant:
  - in a place of safety, located a safe distance from a building, or a place of relative safety within a building, for example, an area of rescue assistance adjoining a vertical evacuation route;
  - during independent or assisted evacuation to a place of safety or a place of relative safety; and
  - in situ when no evacuation is possible, for example, in the case of health facilities, using small fire compartments.
- b) A building with an uncontrolled fire should remain structurally stable in every compartment or space where people remain, including:
  - people waiting in areas of rescue assistance or a place of relative safety;
  - people engaged in evacuation or providing assistance for assisted evacuation; and
  - people located in any space outside the building that would be threatened by structural collapse or in any space between the building and a place of safety.

### 38.2 Principles of fire evacuation for all

It is a fundamental objective of fire engineering design for evacuation that there shall be alternative, safe and intuitive evacuation routes away from the scene of a fire, which can occur at any time and in any part of a building; these evacuation routes shall be available to all building users.

Principles of fire evacuation for all:

- protection and evacuation for all should be incorporated at a sufficiently early stage in the architectural design process;
- vertical evacuation or evacuation to a place of safety, which will tend to be farther away than a place of relative safety, is more stressful than horizontal evacuation of areas as needed, particularly for people with mobility impairments;
- the fire engineering strategy needs to specify which occupants, based on abilities and other characteristics, are to be evacuated to a 'place of safety' and which to a 'place of relative safety';
- the fire engineering strategy needs to specify, based on fire size, location, and rate of growth, which areas are to be evacuated and when vertical evacuation is necessary;
- all lifts (elevators) in new buildings should be capable of being used for people evacuation in a fire situation;
- lifts in existing buildings, when being replaced or undergoing a major overhaul, should be made capable of being used for people evacuation in a fire situation (see 15.6 for more guidance).

**NOTE** Where there are no safe options for vertical movement of people with mobility impairments, it may be necessary for such people to have to wait at places of relative safety until the fire services arrive and complete the evacuation. It is important that such scenarios be discussed and agreed with the fire services in advance, so they can ensure that adequate resources are available for both evacuation and fire fighting.

### 38.3 Assisted fire evacuation

#### 38.3.1 General

A fire engineering strategy is needed that will indicate what is required so that every occupant can be protected from fire, from their location when fire begins through their evacuation and at their location after evacuation, in accordance with accepted principles of fire evacuation for all. Included in these principles are that the features of the building should support successful evacuation and every occupant, whatever his or her abilities, should be able to evacuate independently to the maximum degree possible. However, independent evacuation may not be possible for all occupants, particularly in the case of existing buildings. For those occupants who need assisted evacuation, there should be a strategy for the provision of assisted evacuation, and there may need to be areas of rescue assistance.

#### 38.3.2 Areas of rescue assistance

It is essential that movement to and from each area of rescue assistance (see 3.3) does not encroach on the evacuation travel space of the staircase. Door leaves should also not open into or over this evacuation space.

NOTE 1 There may be competition between staircase evacuees and people using the area of rescue assistance (and reduced ability to achieve objectives) if the evacuation travel space of the staircase overlaps the space used for movement to and from an area of rescue assistance (see Figure 62).

Fire evacuation routes, including all areas of rescue assistance, shall be kept clear at all times.

An area of rescue assistance should be of sufficient size to cope with expected needs in a fire emergency. For example, if there are only two evacuation staircases on a floor in a building (on opposite sides), each area of rescue assistance should be designed to cater for the expected needs of the full floor.

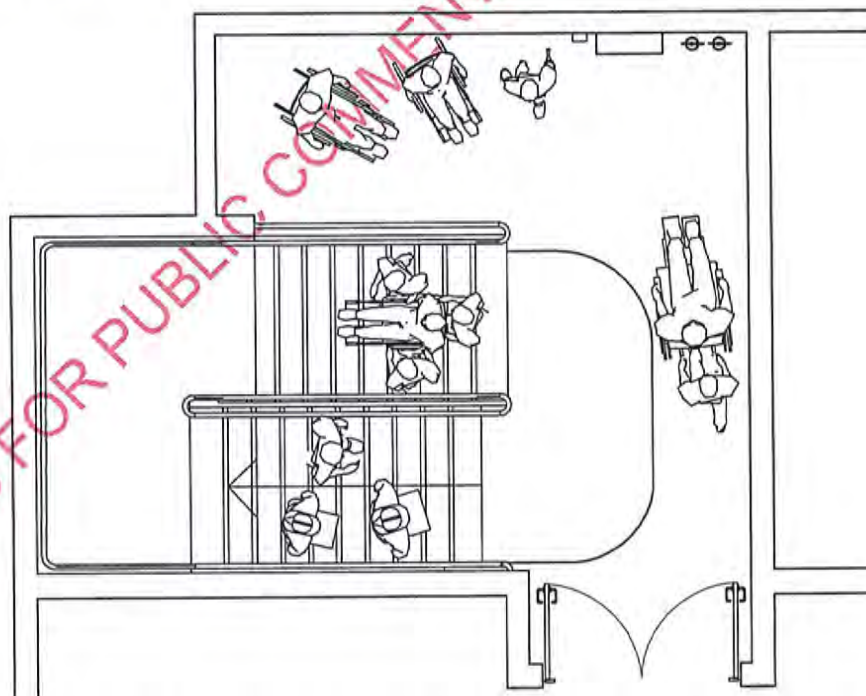

Figure 62 — Example of fire evacuation staircase with an adjoining area of rescue assistance

An area of rescue assistance in a building should:

- be provided on every floor of a building,
- adjoin every evacuation staircase,
- include space for persons in wheelchairs,
- have good lighting and be clearly indicated with good signage,
- be fitted with an accessible and reliable independent communication system fitted at a height of 800 mm to 1 100 mm above floor level, facilitating direct contact with a person in the designated control room for the building,
- be of sufficient size for the storage of an evacuation chair and a manual fire alarm call point, a fire evacuation supply kit containing, for example, smoke hoods, suitable gloves to protect a person's hands from debris when pushing his/her manual wheelchair, etc.,

NOTE 2 Many commercially available smoke hoods are advertised to provide protection from more fire effects than they actually do provide.

- be marked with good signage.

Communication systems at areas of rescue assistance should provide visual feedback to people with hearing impairments that their location has been noted. The control point for the communication systems should be of a robust design to avoid risk of confusion about the location of building users. Where a signal board is used, this should be engraved or otherwise permanently marked to identify the particular building location, and should not rely on sticky labels or translation tables.

#### **38.4 Evacuation chairs**

Evacuation chairs should be capable of:

- being safely and easily operated;
- carrying people of high weight (up to 150 kg);
- going up and down staircases;
- travelling long distances horizontally and externally; and
- compensating for any challenging features of a particular environment, such as narrow or unusually shaped staircases or evacuation paths over rough ground.

#### **38.5 Emerging fire evacuation technologies**

Emerging fire evacuation technologies could include:

- intelligent evacuation management systems;
- directional sounders for locating fire exits on each floor of a building which may be obscured by smoke.

#### **38.6 Fire defence plans**

A fire defence plan elaborates the particular fire engineering strategy which has been developed for a specific building. It is usually in hard copy and/or electronic format and comprises fire engineering drawings, descriptive text, fire safety related product/system information, with supporting calculations and fire test data.

The fire defence plan shall demonstrate a proper consideration for the fire safety, protection and evacuation of the users of the building (occupants, visitors and other users) and who may or may not have a health condition or impairment. This may be a requirement of national legislation.

## 39 Orientation and information

### 39.1 General

The built environment should be designed, constructed and managed to facilitate orientation. Orientation means to find one's way, to avoid obstacles which could cause hazards, and to know when one has reached the destination.

Suitable provision shall be made at the entrance to the building and at decision points within the building to describe the location and nature of the building. In very complex buildings, visual, audible and tactile information should be provided.

Means to achieving satisfactory orientation conditions are:

- planning layouts,
- wayfinding and guided paths with TWSI (see 7.2 and Annex A), other physical support of information (see Clause 35),
- signage (see Clause 40) and symbols (see Clause 41),
- visual contrast (see Clause 35),
- choice of colours (see 35.2),
- avoiding surfaces which might make orientation more difficult,
- lighting (see Clause 33),
- visual, audible and tactile information according to the two-sense principle (see 39.2).

Orientation should be facilitated by differences in acoustics, material, light and colour. The design should indicate the use of the building elements.

To facilitate people with vision impairments who have some residual vision, routes to be followed should have a difference in luminance to the surroundings (see Clause 35).

Additional illumination or visual contrast and tactile information, such as a change in material or tactile walking surface indicators, should be provided at decision points such as entrances, staircases, lifts, etc., to assist orientation and wayfinding.

Tactile walking surface indicators should be used to indicate directional orientation information where no other clues indicate the path of travel. Across large areas, halls and complex buildings, blind people need a tactile route or guiding pattern to follow (see Annex A).

In complex buildings, an audible beacon should be installed in addition to visual and tactile information to provide information on decision points.

To avoid hazards in buildings and in the outdoor environment. See also Clause 4.

## 39.2 Principle of two senses

Supportive measures for information and wayfinding shall be provided in a format that is accessible to people with sensory impairments according to the principle of two senses:

- audible/tactile information for people with vision impairments, and
- visual information for people with hearing impairments.

## 39.3 Audible information

Consideration should be given to provide suitable amplification and acoustic conditions; the message should be easily understandable and unambiguous. See also the principle of two senses in 39.2.

Public address systems should be clearly audible and equipped with a hearing enhancement system as described in Clause 32.

Emergency information and warning systems are described in 15.4.7, 26.14 and 26.15 and in Annex D.

## 39.4 Levels of information

Information should be clear, concise, accurate and timely. Clarity of information can be defined as information that is legible and easily understood. Clarity of information therefore presupposes that people are able to distinguish between the different types of information that they receive.

Information can be divided into three levels:

- Level 1: safety information;
- Level 2: general information;
- Level 3: advertising information.

It is important that these three levels of information be clearly distinguished.

Information should be complete but concise. Too much information is difficult for people to retain.

All information provided should be accurate and consistent.

NOTE Universally accepted pictograms should be used in preference to text. See ISO 7000, ISO 7001, ISO 7010, ISO 16069 and ISO 28564-1.

# 40 Signage

## 40.1 General

Signs should be readable and legible for people who have vision or mental impairments. Well-illuminated, clear and readable signs shall be placed at a consistent height. For heights, see 40.4.

Information with text should be supplemented with graphical symbols to facilitate comprehension for everyone. For graphical symbols see Clause 41.

Signs should be provided in relief and Braille (see 40.10).

The signs should be made of robust materials and be easy to change, clean and repair.

An excessive quantity of signs in close proximity should be avoided, as well as visual material placed too close to wall fixed signs (e.g. posters, timetables, etc.).

Where Braille is used as a complementary or independent feature to tactile signs it should be easy to locate.

NOTE Further guidance for wayfinding and signing is included in ISO 16069 and ISO 28564-1.

## 40.2 Main types of signs

The main types of signs are:

- Orientation signs: sketches, plans, models, etc.
- Directional signs: directional information from point A to B.
- Functional signs: explanatory information.
- Informative signs: purely informative, for example a name.
- Signs for emergency exits (see Annex D).

## 40.3 Placement of signs

### 40.3.1 Placement outside the building

Informative signs shall be located adjacent to the entrance door and be illuminated and clearly visible. The sign shall be placed on the latch side. For design and size of letters, see 40.5.

Communication systems shall also be placed on the latch side and preferably in a range of 1 000 mm to 1 200 mm above ground level.

### 40.3.2 Placement in the building

Orientation signs should be located in accessible places adjacent to, but not directly in, main access routes so that they can be examined without disturbance.

In public buildings there should be an orientation plan immediately inside the main entrance. This plan should follow all relevant design criteria stated in Clauses 4 and 35.

Directional signs should clearly direct people to the facilities. They should be located where directional decisions are made and constitute a logical orientation sequence from the starting point to different points of destination. They should be repeated, not too often, but every time there is a possibility of alteration in the traffic direction.

Directional signage to washrooms should be provided in all parts of a precinct or building.

Stairwells should have information signs identifying all points of entry and exit.

Floor numbers shall be located on each floor at top and bottom of stairs, on handrails and on each side of the outer frame of each lift-car entrance on each floor and prominently displayed elsewhere so they are visible from the lift car at each level.



#### 40.4 Height and location of signs

Directional and functional signs should be located below 1 600 mm where they are easy to approach, to touch and read the raised signs with the fingers (see 40.10 to 40.12).

Signs should be located where they are clearly visible to people who are seated, standing or walking.

Signs should be placed between 1 200 mm and 1 600 mm from the floor or ground surface. It should be possible to approach the sign to be read from a short distance.

Where it is likely that the sign may be obstructed, as in a crowded situation, the signs shall be placed at a height of at least 2 100 mm above the floor. The same requirement applies to signs fixed to the ceiling or projecting from walls. In that case, there should be two signs; one that can be seen from a distance above other people's heads, one as a complement at the height recommended above.

Where there is sufficient space, door signs shall be located on the latch side of the door within 50 mm to 100 mm of the architrave.

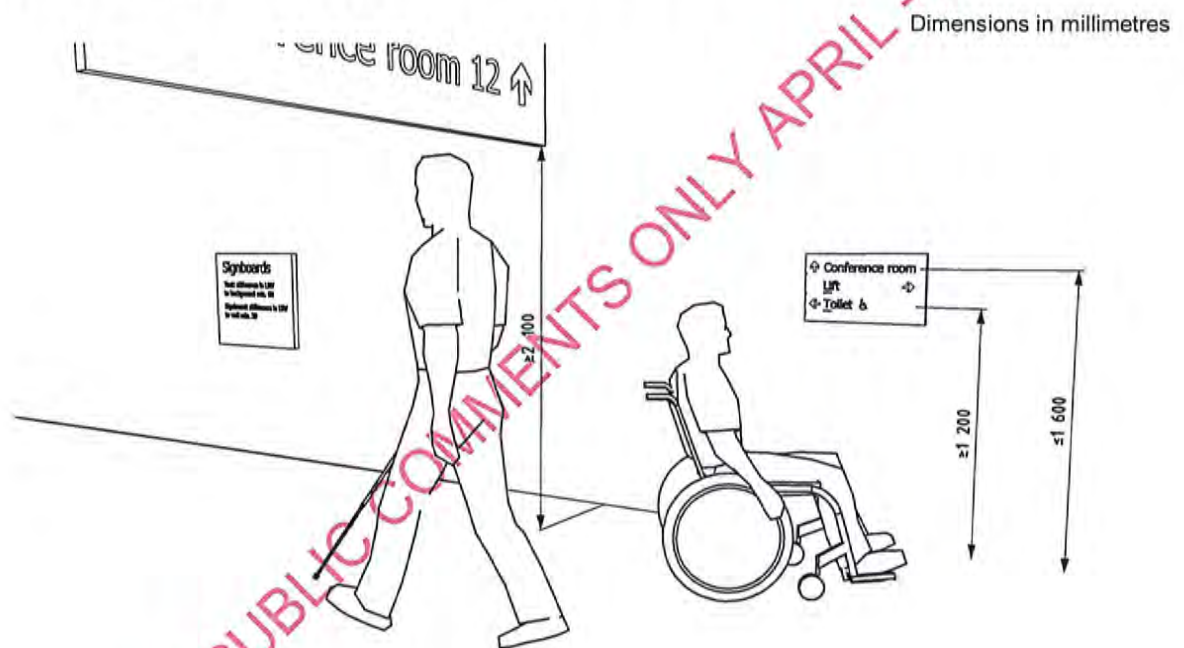

Figure 63 — Height of signs

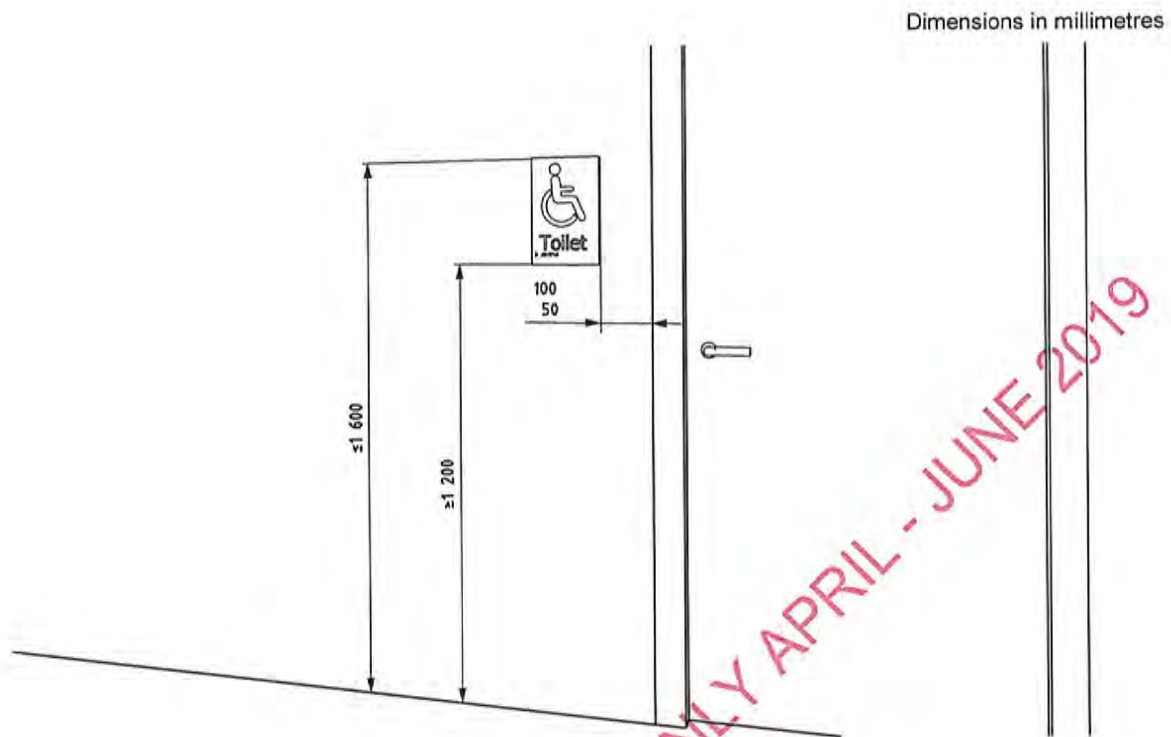

Figure 64 — Location of door signs on the latch side of the door

#### 40.5 Font and size of lettering

The fonts should be easy to read. The font style should be a sans serif font similar to Helvetica or Arial medium.

The letter height depends on the reading distance. A letter height between 20 mm and 30 mm for each metre of viewing distance is preferred. The letter height should not be less than 15 mm.

It is recommended that messages of single words or groups of words begin with an upper case letter and continue with lower case letters (sentence case).

The words should not be placed too close together. Adequate height spacing should separate the lines. Lines of text should be ranged from a vertical line (unjustified).

Signs with a single word may be centre justified.

#### 40.6 Differences in LRV

Minimum difference in LRV for small targets, such as signs and inscriptions, to signboards, should be 60 points.

Signboards should have a minimum difference in LRV from the background of 30 points.

Red-green combination should be avoided. Difficulties in perception can also appear when using the colours green, olive green, yellow, orange, pink and red. Refer to the contrast section in B.7.

#### **40.7 Glare free**

Signs should be glare free when mounted. This depends on how the sign is placed, the material and the illumination. The background, graphical symbols, logos and other features shall be of a matte or low sheen finish.

#### **40.8 Illumination**

Signs should be well illuminated with no glare.

Signs can be luminescent or artificially lit.

#### **40.9 Understandable**

Signs should be readily understandable. They should be designed so as to be simple and easy to interpret. The message should be unambiguous.

Short sentences and simple words should be used. Abbreviations and very long words are hard to understand and should be avoided.

#### **40.10 Provision of raised tactile and Braille signs**

Signs on panels in lifts, room numbers of rooms in hotels, doors to public toilets and so on shall be raised tactile and include Braille (also see 40.4).

The preferred height of raised tactile information is between 1 200 mm and 1 600 mm. Signs with tactile information placed at a lower height should be mounted at an angle from the horizontal (preferably 20° to 30°, max. 45°).

#### **40.11 Tactile letters, figures, signs and graphical symbols**

The height of letters, figures, signs and graphical symbols shall be between 15 mm and 55 mm (see Figure 65).

The minimum height of its relief shall be 0,8 mm; a height between 1 mm and 1,5 mm is preferred (see Figure 65).

The profile of the relief should be shaped as a rounded upside-down turned letter V.



**Key**

- 1 raised tactile letters and graphical symbols, height 15 mm to 55 mm, minimum relief 0,8 mm (1 mm to 1,5 mm relief is preferred)
- 2 Braille text
- 3 Braille locator

**Figure 65 — Example of raised tactile signs and Braille**

**40.12 Braille**

Where an arrow is used in the tactile sign, a small arrow shall be provided for Braille readers.

On signs with multiple lines of text and characters, a semi-circular Braille locator on the left margin shall be horizontally aligned with the first line of Braille text.

Braille should be raised, domed and comfortable to touch. It should be located 8 mm below the bottom line of the text and be left justified.

**40.13 Tactile symbols**

Tactile symbols applied on handrails, doors, maps or floor plans shall have a raised relief contour similar to tactile letters.

**40.14 Tactile maps and floor plans**

Only essential information should be included on a tactile map or floor plan.

Tactile maps shall be angled between 20° to 30° from the horizontal for ease of reading, and the bottom edge shall be at a minimum height of 900 mm. The map should have a level of illumination between 350 lux and 450 lux, without glare.

The key should be located at the bottom of the map and left justified. The use of a recessed Braille locator on the left hand side should assist in locating the legend.

The map shall be orientated with the building.

#### 40.15 Information displays

If video and media information displays are used, they should be placed at a height according to 40.4 and their lettering, etc., should be in conformity with the recommendations above.

Glare from artificial and natural lighting on the screen shall be avoided by:

- positioning the display or the screen out of direct light; or
- shading the display or the screen.

A complementary audible information system should be provided.

### 41 Graphical symbols

ISO/TC 145 *Graphical symbols* has developed the following standards for graphical symbols: ISO 7000, ISO 7001 and ISO 7010. These include graphical symbols relevant to accessibility and a selection is shown below (see Figures 66, 67 and 71).

Graphical symbols should be used in conjunction with building signage systems wherever possible.

Graphical symbols shall:

- be highly contrasted with a minimum difference in LRV of 60 points and properly illuminated,
- be used on guides and directional signage.

Graphical symbols on directional and door signs should be tactile, and should be accompanied by raised lettering and Braille (see 40.13). Signs above a height of 1 600 mm do not need to be tactile, nor to include raised lettering or Braille information.

The size of graphical symbols is dependent on the viewing distance (D). The minimum size of the inner outline of the frame of graphical symbols (s) can be derived from formula  $s = 0,09 D$ , applicable for a viewing distance of 1 000 mm to 10 000 mm.

The following accessible graphical symbols shall be used to denote particular components of a facility. The following facilities for disabled persons shall be marked as:

- a) Those relating to people with mobility impairments:
  - car parking places (parking places, garages),
  - access and entrances without steps to buildings, especially where they are not identical with the main entrance,
  - accessible lifts, in cases where not all lifts are accessible; lifting platforms and similar mounting devices,
  - accessible sanitary rooms,
  - wheelchair viewing spaces and accessible seating,
  - changing rooms,
  - steps or hoists providing access to swimming pools.

- b) Those relating to people with vision impairments:
  - guide dog facilities,
  - locations where audible and tactile information is provided.
- c) Those relating to people with hearing impairments:
  - telephones and emergency call facilities, equipped with sound amplification,
  - provision of an assistive listening system.



Figure 66 — Accessible facility or entrance (ISO 7001, PI PF 006)



Figure 67 — Sloped or ramped access (ISO 7001, PI PF 022)



NOTE This graphical symbol is a combination of ISO 7001, PI PF 006 and ISO 7001, PI PF 003.

**Figure 68 — Toilets — Accessible, female and male**



NOTE This graphical symbol is a combination of ISO 7001, PI PF 006 and ISO 7001, PI PF 005.

**Figure 69 — Toilets — Accessible, female**



NOTE This graphical symbol is a combination of ISO 7001, PI PF 006 and ISO 7001, PI PF 004.

Figure 70 — Toilets — Accessible, male



Figure 71 — Accessible elevator or lift (ISO 7001, PI PF 031)





NOTE Figure 72 is a combination sign, which, according to ISO 3864-1, is a sign that combines a safety sign and one or more associated supplementary signs on the same rectangular carrier. The signs used in Figure 72 are the following:

- Running man (centre of the combination sign): Use ISO 7010-E001, "Emergency exit (left hand)" or ISO 7010-E002, "Emergency exit (right hand)", depending of the direction to indicate (ISO 7010-E002 is the sign used in Figure 72).
- Arrow (left of ISO 7010-E001 or right of ISO 7010-E002): Supplementary arrow sign to be used with the emergency exit sign to indicate direction.
- Supplementary sign (opposite to the arrow) ISO 7001, PI PF 006, "Full accessibility or toilets – accessible".

Figure 72 — Accessible emergency exit route

## 42 Management and maintenance issues

Effective management of the built environment is essential to ensure that a building can be used by everyone. Management policies and procedures will be required to ensure that accessibility is maintained on an ongoing basis.

Annex E identifies the key areas for attention.

## Annex A (informative)

### Tactile walking surface indicators (TWSIs)

#### A.1 General

When persons with vision impairments travel alone, they may encounter problems and dangers in various situations. In order to avoid obstacles and obtain information about their locations, these pedestrians travelling alone use all the available information, including tactile information, long canes and through the soles of their shoes. Tactile walking surface indicators (TWSIs) have been developed to assist the movement of persons with vision impairments.

The TWSIs are used to assist persons with vision impairments travelling alone. These TWSIs should be designed and installed based on a simple, logical, and consistent layout. This allows tactile indicators to not only facilitate the movement of persons with vision impairments through familiar places, but also support their movement and space recognition in places they are visiting for the first time.

Currently, several TWSIs that convey different information are used; however, the capability of detecting differences in tactile patterns through their shoes or by means of a long cane varies depending on the individual. Therefore, it is necessary that empirical and experiential research be used to ensure that TWSIs can be detected and recognized by potential users. To achieve maximum effect in conveying information, it is important that they are installed in a flat, smooth surface where persons with vision impairments can identify them without interference from any irregular walking surface.

It is also necessary to ensure that persons with low vision as well as persons who are blind can effectively use TWSIs. For this purpose, TWSIs should be easily detectable by vision. This is achieved through the application of a minimum visual contrast between the TWSIs and the surrounding pavement or floor surface.

While TWSIs shall be effective for persons with vision impairments, it is necessary to ensure that the surface structure and materials used are not detrimental to other pedestrians, including those having mobility impairments.

This annex specifies two types of TWSIs: attention indicators and guiding indicators. Tactile attention indicators may be installed at the vicinity of pedestrian crosswalks, the platforms of railway stations, and both the top and bottom of stairs and ramps, and in front of escalators, travelators and elevators, and the like to ensure safety. Tactile guiding indicators may be used in combination with attention indicators in order to indicate the walking route where no other tactual information is available to get from one place to another.

At present, patterns and installation methods of TWSIs vary from country to country. This annex specifies the basic criteria for detectability and how to differentiate between each type of pattern used, and provides some examples.

#### A.2 Application

TWSIs are installed in pedestrian facilities throughout the built environment where there is a situation that is not highlighted by any other feature detectable by persons with vision impairment.

## **A.3 Detection and discrimination**

### **A.3.1 Tactile contrast**

TWSIs shall be detectable from surrounding or adjacent surfaces through the soles of the shoes and/or by the long white cane. Adjoining surfaces shall be smooth, to enable detection and discrimination of TWSIs.

When attention patterns and guiding patterns are combined, it is necessary that persons with vision impairment be able to clearly identify both of them.

### **A.3.2 Visual contrast**

TWSIs shall be readily detectable and discriminable from the surrounding or adjacent paving surfaces using low vision. Visual contrast is defined in 3.63 and is assisted by good illumination.

The effective area of the TWSIs should have a high visual contrast with the immediate surrounding pedestrian surface in both wet and dry conditions. The difference in light reflectance or CIE Y-value between TWSIs and their immediate surrounding surface shall be greater than 30 points for integrated units and greater than 40 points for discrete units, with a minimum reflectance value of the lighter surface of 50 points.

Where TWSIs are used for hazards, the minimum difference in light reflectance value should be 50 points and the reflectance value of the lighter surface minimum 60 points.

When the required luminance contrast between two surfaces, for example between TWSIs and surrounding surface, cannot be achieved, the addition of a compliant contrasting continuous band of minimum 100 mm in width adjoining to the TWSIs shall be used.

For methods for determination of visual contrast, see B.7.

As persons with vision loss often have a colour deficiency, colour difference is only used to supplement visual contrast.

### **A.3.3 Prevention of tripping**

TWSIs have a maximum height above the surrounding pavement or floor surface of 5 mm. They shall have bevelled or rounded edges to reduce the likelihood of tripping and to enhance safety and negotiability for people with mobility impairments.

## **A.4 Requirements for attention pattern**

### **A.4.1 Arrangement**

The attention pattern should be constructed of truncated cones or domes arranged in a square grid or in diagonal rows (see Figures A.1 and A.2).

### **A.4.2 Height**

The height of truncated cones or domes shall be 4 mm to 5 mm (see Figure A.1).

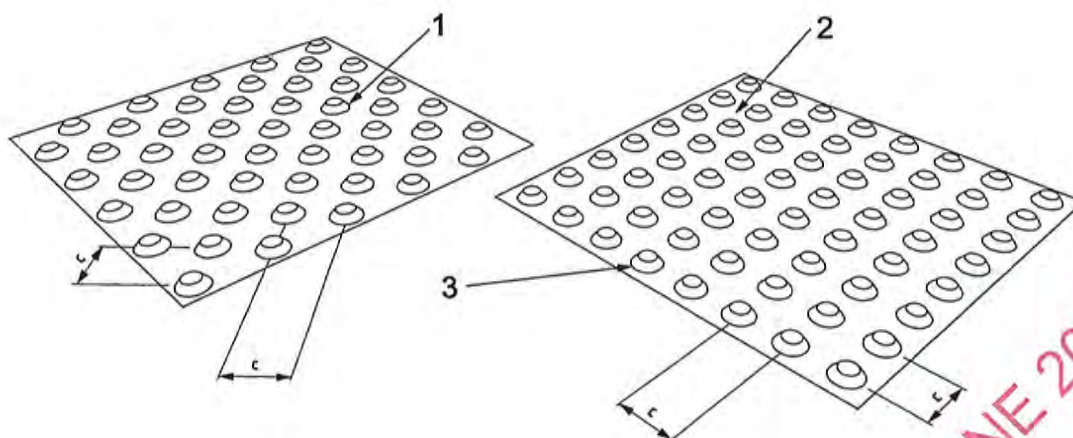

#### Key

- 1 cones arranged in diagonal rows
- 2 cones arranged in square grid
- 3 truncated cone [height 4 mm to 5 mm, top diameter 12 mm to 25 mm, base diameter = top diameter plus  $(10 \pm 1)$  mm]
- c centre spacing

Figure A.1 — Arrangement, spacing and dimensions of truncated cones

### A.4.3 Specification for truncated cones

#### A.4.3.1 Diameter of truncated cones

The top diameter of truncated cones should be between 12 mm and 25 mm, and the diameter of the lower base of truncated cones should be  $10 \text{ mm} \pm 1 \text{ mm}$  greater than the diameter of the top (see Figure A.1).

#### A.4.3.2 Spacing of truncated cones

The distance between the centres of adjacent truncated cones should be in relation to the top diameter as shown in Table A.1.

Table A.1 — Spacing in relation to top diameter of truncated cones

Top diameter of truncated cones, mm	Centre spacing, mm
12	42-61
15	45-63
18	48-65
20	50-68
25	55-70

NOTE 1 Within the range of centre spacing, the maximum spacing provides a larger gap between the truncated cones, which improves detectability under foot while the minimum spacing provides a smaller gap, which improves detectability by long cane used by persons with vision impairment.

NOTE 2 The spacing refers to the shortest distance between the centres of two adjacent truncated cones which may be parallel or at  $45^\circ$  to the border of the tactile area depending on whether the truncated cones are arranged in a square grid or in diagonal rows.

## A.4.4 Specifications for domes

### A.4.4.1 Diameter of domes

The diameter of the base of domes should be between 25 mm and 35 mm (see Figure A.2).

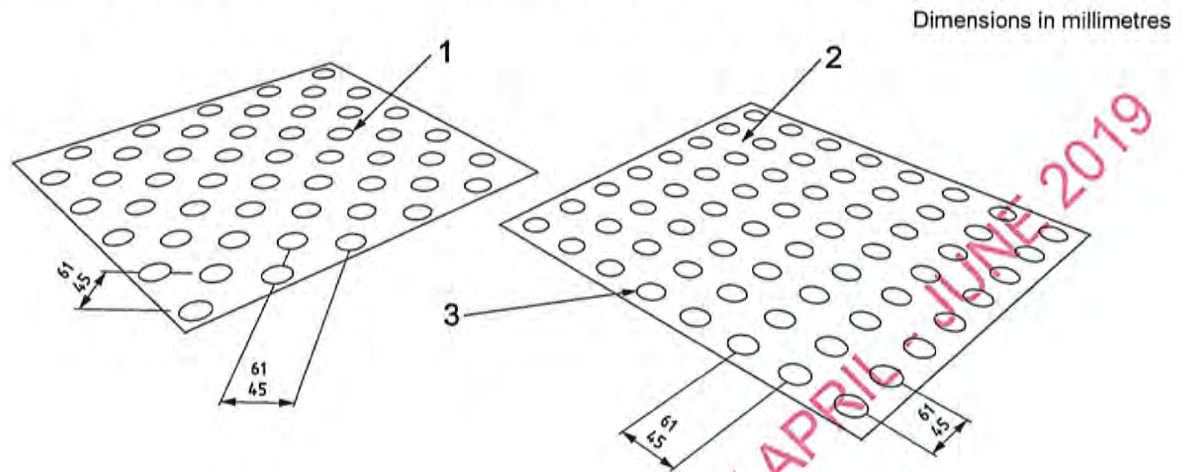

#### Key

- 1 domes arranged in diagonal rows
- 2 domes arranged in a square grid
- 3 dome height 4 mm to 5 mm, base diameter 25 mm to 35 mm

Figure A.2 — Arrangement, spacing and dimensions of domes

### A.4.4.2 Spacing of domes

The distance between the centres of adjacent domes should be between 45 mm and 61 mm (see Figure A.2).

**NOTE** Within the range of centre spacing, the maximum spacing provides a larger gap between the domes, which improves detectability under foot while the minimum spacing provides a smaller gap, which improves detectability by long cane used by persons with vision impairment.

## A.5 Requirements for guiding pattern

### A.5.1 Arrangement

A guiding pattern should be constructed of parallel flat-topped bars, ribs or sinusoidal rib pattern (see Figures A.3, A.4 and A.5).

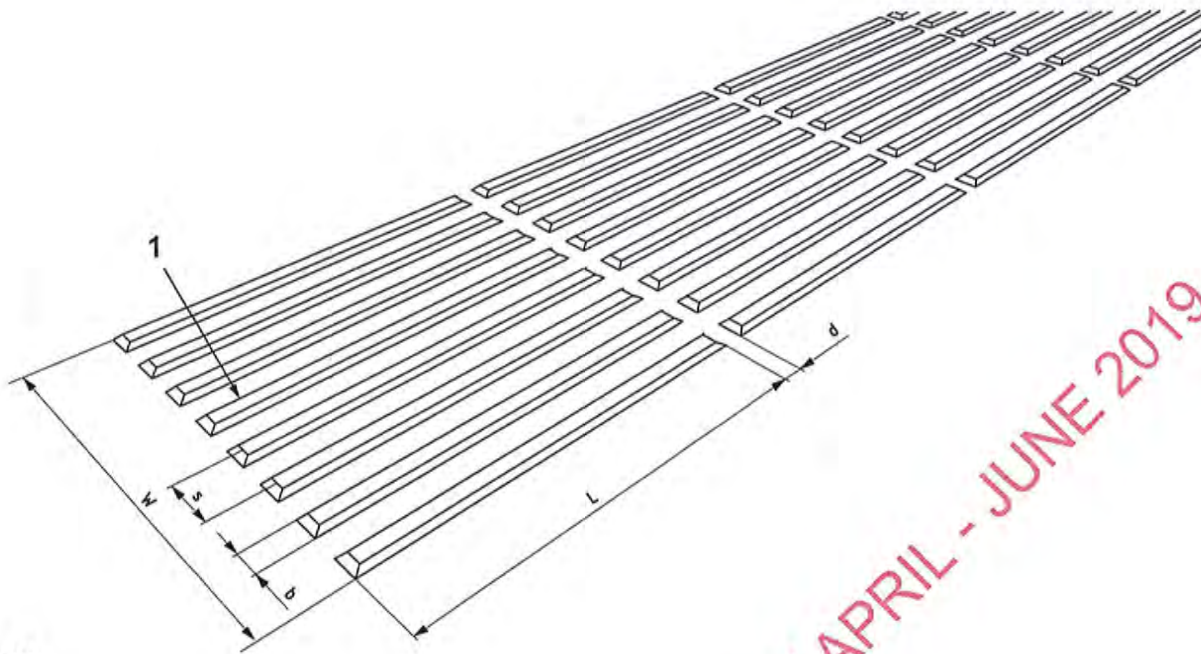

**Key**

- |   |   |   |                |
|---|---|---|----------------|
| 1 | flat-topped elongated bars, height 4 mm to 5 mm, bevelled | L | minimum 270 mm |
| s | spacing of ribs   | W | minimum 250 mm |
| b | width at base   | d | minimum 30 mm  |

**Figure A.3 — Spacing and dimensions of flat-topped elongated bars**

**A.5.2 Specifications for flat-topped elongated bars**

**A.5.2.1 Height of flat-topped elongated bars**

The height of flat-topped elongated bars shall be 4 mm to 5 mm (see Figure A.3).

**A.5.2.2 Width of flat-topped elongated bars**

The width of the top of flat-topped elongated bars should be between 17 mm and 30 mm. The width of the base should be 10 mm  $\pm$  1 mm wider than the top (see Figure A.3).

**A.5.2.3 Spacing of flat-topped elongated bars**

The distance between the axes of adjacent flat-topped elongated bars should be in relation to the top width as shown in Table A.2.

**Table A.2 — Spacing in relation to the width of the top of flat-topped elongated bars**

Width of flat-topped elongated bars, mm	Spacing, mm
17	57-78
20	60-80
25	65-83
30	70-85

### A.5.3 Specifications for rib pattern

#### A.5.3.1 Height of ribs

The height of ribs shall be 4 mm to 5 mm (see Figure A.4).

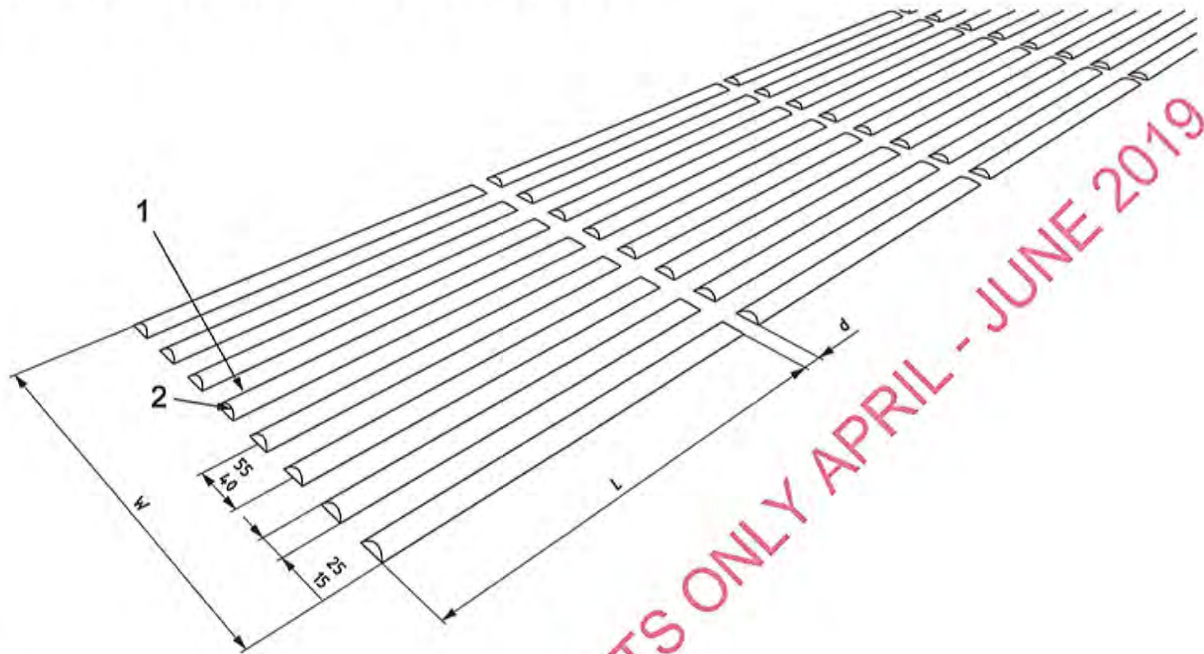

#### Key

- 1 ribs, height 4 mm to 5 mm
- 2 bevelled

- L minimum 270 mm
- W minimum 250 mm
- d drainage gap 20 mm to 30 mm

Figure A.4 — Spacing and dimensions rib pattern

#### A.5.3.2 Width of ribs

The width of the base of ribs should be between 15 mm and 25 mm.

#### A.5.3.3 Spacing of ribs

The distance between the axes of two adjacent ribs should be 40 mm to 55 mm.

### A.5.4 Specifications for sinuously ribbed pattern

#### A.5.4.1 Height of wave crests

The difference in level between the wave crest and the wave trough of a sinuously ribbed pattern shall be 4 mm to 5 mm (see Figure A.5).

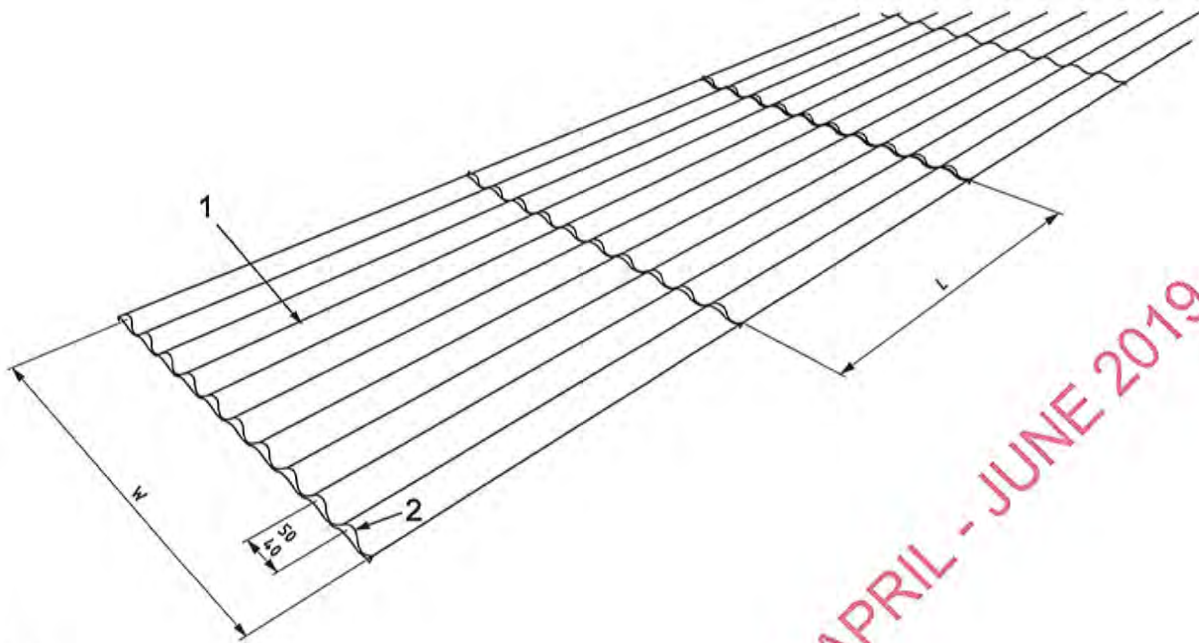

**Key**

- 1 sinusously ribbed pattern, height 4 mm - 5 mm
- 2 bevelled
- L minimum 270 mm
- W minimum 250 mm

**Figure A.5 — Spacing and dimensions of sinusously ribbed pattern**

**A.5.4.2 Spacing between wave crests**

The distance between the axes of two adjacent wave crests of sinusously ribbed pattern should be 40 mm to 52 mm.

**A.5.5 Length**

The length of flat-topped elongated bars, ribs or sinusoidal rib pattern should be more than 300 mm. Where there is a risk of water ponding, a drainage gap of between 20 mm to 30 mm shall be provided. At the ends and any interruption of the flat-topped elongated bars, ribs or sinusoidal rib pattern shall be bevelled to negate the possibility of tripping. To maintain the continuity of the guiding pattern, gaps should not be more than 30 mm wide.

NOTE It is easier to follow guiding patterns that are as continuous as possible.

**A.6 Materials**

Tactile indicators shall be made of materials that are durable, and should maintain the required visual contrast.

They shall be slip resistant. Careful attention should be given to the selection of materials for TWSIs to ensure they are not and do not appear to be slippery.



## **A.7 Installation**

### **A.7.1 General**

This clause shows the basic principles and specifications for installation of TWSIs, and provides examples of applications.

National requirements for the installation of TWSIs shall take into consideration existing national conditions, design requirements for the accessible built environment, and national regulations.

Minimum depth and width dimensions for installation of TWSIs may need to be increased for safety, because this increases the probability of detection.

When TWSIs are installed, the base surface of the TWSIs should be less than 3 mm above the surrounding ground or floor surface so that they do not cause a tripping hazard.

TWSIs should be fixed so that there is no likelihood of edges lifting.

### **A.7.2 Principles for installation of TWSIs**

When used as a system to aid orientation and safety, guiding and attention patterns should be used in a logical, sequential manner, with beginning and end points, between which intersections, decision points or hazards are indicated.

TWSIs may also be used individually to indicate hazards or locations.

### **A.7.3 Principles for installation of attention patterns**

Effective depth and width of attention patterns should be a minimum of 560 mm.

When an attention pattern is used to indicate a hazard, it should be extended the full width of the hazard, from each direction from which the hazard can be approached, and should be set back a minimum distance of 300 mm from the hazard.

NOTE The definition of hazard varies by situation and by country.

When an attention pattern is used to indicate a decision point, the effective width and depth should be a minimum of 560 mm by 560 mm.

FDBNS FOR PUBLIC COMMENTS ONLY APRIL - JUNE 2019

## Annex B (informative)

### Human abilities and associated design considerations

#### B.1 General

The prime objective in designing, constructing and managing the accessible built environment is to ensure that it satisfies the diverse needs of all of its intended users. Such an environment should reasonably satisfy the needs of any one individual without unreasonably compromising those of another. This is particularly important in areas of health and safety. In many instances, the use by specific individuals of assistive products assists them in using the built environment.

Every effort should be made to address constraints such as limitations of space or topography on the development of new environments that suit everyone's needs. Different constraints are likely to be encountered when attempting to modify the layout and structure of an existing building or external environment. However, as many as possible of the individual provisions within this International Standard should be adopted, whether the environment is newly constructed or an existing one is to be modified.

B.2 describes the principal human faculties that need to be considered when designing, constructing and managing the built environment. As well, the section highlights a number of design considerations that should allow the environment to accommodate different levels of performance.

Physical, sensory and mental faculties vary from person to person. Diversity is normal. However, some differences may be heightened through age or social condition, be congenital or result from accident or illness. Disability may be temporary or permanent, or in transition.

#### B.2 Physical abilities

##### B.2.1 General

Physical faculties include walking, balance, handling, pulling, pushing, lifting and reaching. Many activities involve simultaneous use of more than one of these skills.

##### B.2.2 Walking

For some people walking on the level or up gradients is difficult. Some people may have a limited range of motion or may use a mobility device such as a wheelchair or a walker. They may need to stop frequently, to regain strength or catch their breath.

In addressing the needs of people with walking limitations, the principal design considerations include:

- a clear unobstructed path of travel and an appropriate width;
- the proximity of facilities to one another;
- the ease of incline of gradients and of the pitch of steps and stairs;
- the availability of seats;
- the number of steps in a flight;

- optional means of travel from one level to another;
- the provision of handrails on both sides;
- the evenness, firmness and slip-resistance of walking surfaces.

To prepare for emergencies, egress needs to be established by planning architectural and evacuation strategies. Specific accommodation and management systems need to be planned to provide assisted means of egress in the event of emergency (see Annex D).

### **B.2.3 Balance**

People with difficulty in balancing are expected to benefit from controls within easy reach.

A surface which a person may stumble against or walk into should be designed to limit abrasion.

### **B.2.4 Handling**

Handling involves the use of one or both hands. Some people are left-handed. Others might, for a variety of reasons, not have the use of either one or both of their hands. Facilities and components should be designed to be suitable for use with one and with either hand.

Handling includes gripping, grasping and manipulation. Each of these has a different purpose with specific design considerations. For instance, components should be designed to be graspable. Their circumference of the supporting structure and stability are critical.

Manipulation involves the moving, turning and twisting of components with a hand or hands. For those who have limited manipulation abilities, size and shape and ease of movement are critical.

Manipulation by using a pushing, pulling or pressing action using a clenched fist, or by using the wrist or the elbow, is preferred.

### **B.2.5 Strength and endurance**

Strength and endurance may be required on sloping paths and floors, stairways and long travel distances, when sustained effort may be needed.

For those with limited endurance, frequent resting places are essential.

People generally find it easier to push than pull. This is particularly so if the individual uses a wheelchair. Nevertheless, self-closing devices on manual doors can be difficult for some people to operate, particularly if the doors are required to resist wind forces. For these reasons, doors that open and close automatically are preferred.

### **B.2.6 Lifting**

Activities such as opening a vertically sliding sash window and an upward opening access gate should be designed to be easily operated with minimal force.

### **B.2.7 Reaching**

Telephones, desks, counters and work surfaces, electrical and other service controls, taps, door and window furniture should be positioned within reach. Comfortable reach ranges should be considered to ensure use by a greater number of people.

A "comfortable reach range" has been defined as one that is appropriate to an activity that is likely to be frequent and in need of precise execution and that does not involve stretching or bending from the waist.

An "extended reach range" has been defined as one that is appropriate to an activity that is not likely to either need precision or to be frequent and that can involve stretching or bending from the waist.

Having components within easy reach is particularly important for those with more severe limitations in mobility.

For wheelchair users, the reach range is limited depending on the seated position. Where reach is across a desk or worktop the range is limited by presence or design of the wheelchair's arms.

The reach range is also dependent on the height of the person, the use of their arms and balance and mobility of the upper body.

## **B.2.8 Speech**

Speech is the expression of thoughts by means of articulate sounds. Where two-way communication is required, the built environment should be designed to facilitate communication with information in visual and audible formats, with adequate illumination and appropriate alarm systems.

## **B.3 Sensory abilities**

### **B.3.1 General**

Sensory abilities are abilities by which the body perceives an external stimulus. They include sight, hearing, touch, smell and taste. This International Standard does not deal with matters relating to smell and taste.

### **B.3.2 Sight**

Vision allows an individual to be aware of the luminance of surfaces and objects and their form, size and colour.

For people who are blind or have a severe vision impairment, the provision of suitable tactile walking surface indicators and tactile or acoustic warnings at hazardous locations should provide information on using the built environment and should limit the risk of injury. The built environment can be designed for orientation by providing sound cues and tactile cues.

Differences in friction between one floor surface, or one stair tread surface and the next should be avoided. Therefore, adjacent surfaces that display different standards of slip-resistance, or that depend on raised surfaces, should be carefully considered.

An effective visual contrast between surfaces or objects helps to identify critical locations.

Simple and clear images should be used.

Visual contrast between adjacent surfaces and components should be carefully considered.

An environment that accommodates a broad range of visual characteristics should have:

- a simple, logical and easily understood arrangement, preferably with intersecting routes at right angles to each other;
- an easily discernible system of "wayfinding";
- visual contrast between adjacent objects and surfaces where it is necessary to provide important information;
- choices of colour that satisfy the needs of those with anomalous colour vision;

- appropriate warnings of the edge of abrupt changes of level or the existence of obstructions;
- no reflections from floor and wall finishes;
- careful placement of mirrors and glazing, to prevent dazzling and confusion;
- a suitable level of lighting, free of glare;
- complementary audible information.

### **B.3.3 Hearing**

Hearing allows an individual to be aware of sound, to determine its direction and, possibly, its source, and to discern its pitch, frequency, volume and variation. Its quality contributes to an effective means of communication and information. A low level of background noise is essential.

Hearing enhancement systems amplify audible communication and can be used by people who have a hearing impairment. They include a direct wire system, an induction loop system, an infrared system and a radio frequency system. All of these systems transmit a signal. Special-purpose receivers are required for infrared and radio frequency systems, while hearing aids equipped with a T-switch are capable of receiving the signal from an induction loop system. Receivers can be equipped to be compatible with hearing aids. Written information that complements oral information concerning fire and other emergencies is especially important.

The selection of structural and surface materials can make a substantial difference in audibility. Auditoriums, meeting rooms and reception areas can benefit from additional sound enhancement such as a hearing enhancement system.

The careful design of illumination can assist in communication such as lip reading and sign language.

Most people with hearing impairments use a hearing aid which amplifies all sounds caught by the microphone, making communications very difficult in noisy environments.

### **B.3.4 Touch**

Touch stimulates the perception of an object through physical contact. For those individuals who use touch in the built environment, it is important to consider the selection of surfaces that do not cause distress or injury.

Surfaces should be free of abrasions and not cause an allergic reaction. Some metals may cause adverse reactions when touched so their use should be carefully explored.

## **B.4 Mental abilities**

### **B.4.1 General**

Mental faculties include those processes that are carried out in the mind of the individual. They include cognition, intellect, interpretation, learning and memory. To provide a usable environment for the population at large, all means of communication should have an immediate impact and be easily understood.

### **B.4.2 Cognition**

Cognition is the acquisition of knowledge and understanding through thought, experience and the senses. By this means, and through recognition, people can understand and interpret signs and other forms of information or instruction.

### **B.4.3 Intellect**

Intellect is the faculty of reasoning and understanding objectively, especially with regard to abstract matters.

### **B.4.4 Interpretation**

Interpretation involves understanding messages and information as having a particular meaning or significance.

### **B.4.5 Learning**

Learning is central to many aspects of understanding, reasoning and interpretation. A failure to recognize words and their meanings may adversely affect an individual's ability to move successfully and safely in the built environment.

### **B.4.6 Memory**

Memory is the ability to remember information. As people age, some find it increasingly difficult to absorb new information so changes in the environment should be carefully considered before implementation.

### **B.4.7 Design considerations that take account of mental abilities**

Aural and visual messages should be simple, clear and have immediate impact. Figures, symbols and simple words are likely to be the most effective. Symbols should be instantly recognizable as representing images seen and activities undertaken in everyday life.

Special design considerations:

- simple and clear planning layout; key rooms or spaces designed so they are easy to find;
- whenever changes are undertaken, clear and simple information with respect to the new layouts should be provided;
- self-explanatory environment; design should indicate the use of the built environment or elements in it; unnecessary complexity should be avoided;
- simple, intuitive design of circulation routes;
- doors designed so that their operation is intuitive, whether they are push, pull or sliding doors;
- text signage that uses plain language;
- aural and visual messages which are conspicuous, concise, comprehensible and relatively frequent;
- wayfinding plans or maps that clearly indicate the person's position in the building or facility, and which do not include extraneous information;
- wayfinding cues that are easy to follow, e.g. tactile, graphic, audible or architectural;
- directional and other information which combines text with universally recognizable symbols;
- signs with graphics that are in conformance with ISO 7000 and ISO 7001;
- in areas where key cards are used for access, such as hotels, the need for fine motor control and precise timing of the swipe of the card in the reader should be minimized.

## **B.5 Additional factors**

### **B.5.1 Accommodating the developing child**

An element of risk is an essential part of a child's development. It is important to ensure that the built environment is safe for children.

### **B.5.2 Accommodating ageing adults**

The life span within the human population is increasing. We expect more and more to maintain an economic and social life within both the public and private domains as we age. However, many human faculties are in marked decline as we age and familiarity with a particular environment is an aid.

### **B.5.3 Diversity of stature**

There is a wide diversity of stature within the human population. Predominantly, this has to do with the average height of people in various parts of the world. The increase in tourism, business travel and population migration has led to a demand for more rationalization, internationally, in the use of anthropometrics and ergonomics and in their influence on the design of the built environment. The provisions in this International Standard include ranges that should accommodate those regional differences. The ranges have been set so that member nations who decide to adopt specific criteria that reflect their own circumstances do not unduly inconvenience other individuals.

The ranges included for the positioning of components or the heights of, for instance, steps, should also recognize the needs of those who do not reach their anticipated full height.

Changes in diet and an increasing use of the motor car for short journeys, for instance, have combined in a trend towards increased girth and weight of some populations. It remains to be seen whether this leads to demands for an increase in specific spatial and stability standards. These matters are beyond the scope of this International Standard.

## **B.6 General design considerations for wheelchair users**

### **B.6.1 Application and manoeuvring space**

Manoeuvring space of 1 500 mm diameter shall be provided in all areas where a significant change in direction for wheelchair users and persons with walking aids is required.

*Exceptional considerations for existing buildings in developing countries:* In some member states where shorter wheelchairs are generally used due to market situations, the manoeuvring space may be reduced to 1 200 mm. Whenever possible this circle should be increased to 1 500 mm.

The dimensions stated in this International Standard are related to the footprint of commonly used wheelchair sizes and users (see Figure B.1).

The footprint for a wheelchair within this International Standard is based on ISO 7176-5 and ISO/TR 13570-2<sup>1)</sup> and is 800 mm wide and 1 300 mm long.

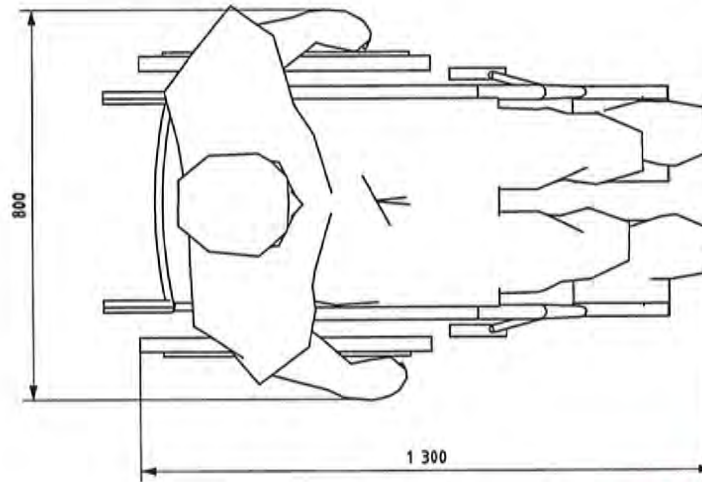

Figure B.1 — Footprint of a wheelchair user

### B.6.2 Space allowance for wheelchair users

Wheelchairs have different dimensions and space requirements depending on the user and the type of wheelchair. The type of wheelchair used is dependent on whether the wheelchair is to be used outdoors or indoors.

This International Standard does not cater for people who need special adaptations to their wheelchair, for example, if they have a stiff leg and have to sit with their leg stretched out, if the back of the chair is lowered or if an exceptionally wide wheelchair is needed.

The circulation space requirements of wheelchair users should be established by taking into account the maximum overall dimensions of the wheelchair as shown in Figure B.1.

At a national level, it should be decided what types of wheelchairs should be considered in different types of built environment.

When wheelchairs are pushed, the total length occupied by the chair and occupant is 1 500 mm, when stationary and 1 750 mm when moving.

To propel a manual wheelchair, a clearance of not less than 50 mm, and preferably 100 mm, is needed. Over longer travel distances, additional space may be required.

The area required for turning is dependent on the ability of the user to manoeuvre the wheelchair. Often turning is done with several movements with the wheelchair, including reversing. The area needed is dependent on the number of backing operations.

Figure B.2 gives examples of simplified 180° space requirements of persons in different types of wheelchairs.



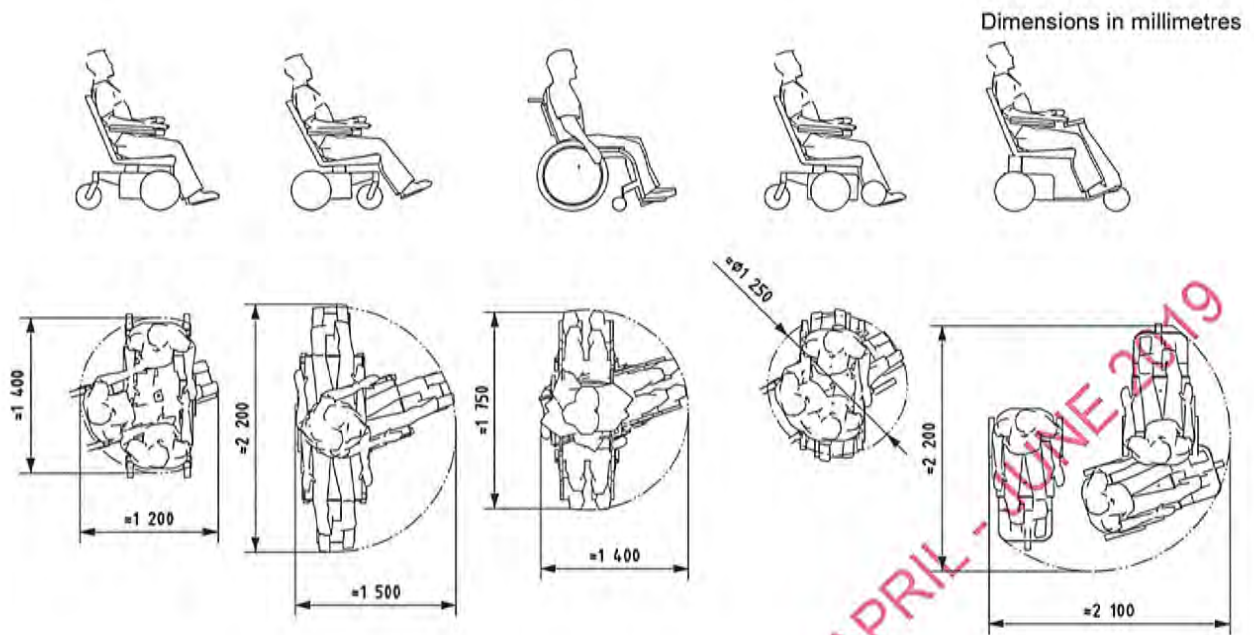

Figure B.2 — Examples of simplified 180° space requirements of persons in different types of wheelchairs

### B.6.3 Reach range

Most wheelchairs have a seat height between 460 mm and 550 mm. The seated position of a wheelchair user restricts arm reach in both vertical and horizontal directions, even when the occupant has full use of his or her arms and upper body. Many wheelchair users have limited mobility in their arms or limited balance makes it difficult to lean forward without risk of falling from the wheelchair.

The comfortable reach of a wheelchair user is between 400 mm to 1 100 mm above floor level and a maximum side reach of 250 mm from the outer side of the wheelchair.

To allow front approach to elements by wheelchair users, sufficient space should be provided below the element to allow for the wheelchair user's knees and preferably the armrests of the wheelchair.

### B.6.4 Reach of users seated in wheelchairs — Distance from corner and other barriers

The ability to reach anything in the corner of a room is limited by the wheels or the foot rest of the wheelchair.

The maximum distance a wheelchair user can reach towards any wall or corner depends on the size of the wheelchair and the person's mobility in the arms.

### B.6.5 Space around elements to provide reachability

A manoeuvring space of 1 500 mm diameter should be provided where needed.

A minimum unobstructed width for side approach of at least 900 mm should be provided.

### B.6.6 Space to provide clearance for wheelchair user's knees

At desks and counters, tables or public telephones, sufficient space should be provided below the item in question to provide clearance for the wheelchair user's knees and, preferably, the wheelchair armrests so as to allow maximum reach.

Where only knee space is required (as in the case of washbasins and counters), the space under the work surface should be at least 800 mm wide, 600 mm deep at foot level and at knee level, with a minimum free height of 700 mm.

### **B.6.7 Convenient height of worktops**

For wheelchair users, the height of worktops should be between 740 mm and 800 mm.

### **B.6.8 Eye level**

The eye level of a seated person is between 990 mm and 1 250 mm. This dimension should be taken into account in elements such as windows, information desks, counters or glazed doors.

## **B.7 Visual contrast**

### **B.7.1 General**

Appropriate use of visual contrast between adjacent colours and/or surfaces allows persons with vision impairments to gather the information they need but also assists all users to move around, identify features and communicate with others.

People with visual impairments may be unable to perceive some or all colours. However many visually impaired people can perceive light and dark. The main feature of a surface, which appears to be strongly correlated with the ability of partially sighted people to identify differences in colour, is the amount of light the surface reflects, or its light reflectance value (LRV). Differences in hue (the nature of the colour) or chroma (the intensity of the colour) alone do not provide adequate visual contrast<sup>[76]</sup>.

**NOTE** A study by Bright and Cook<sup>[76]</sup> is relevant for this International Standard as it is drawn from the results of 31 people who were visually impaired and the tests were carried out under an illuminance of 100 lux, the illuminance required for all horizontal surfaces inside buildings. Because the ability to detect differences in contrast increases with the illuminance on the surfaces, the adoption of a method for the determination of visual contrast based on an illuminance of 100 lux gives enhanced confidence to their adoption at higher illuminances.

The provision of good lighting is essential for the perception of visual contrast. Adequate illumination is required to provide an adequate LRV sometimes called the Luminous Reflectance Value as defined as CIE Y (see CIE, 2004, "Colorimetry"). In general, where the level of illumination is low, a higher level of visual contrast is required.

It is for reasons of weathering, plus variations in lighting levels (e.g. in strong sunlight or after dark) that, externally, differences in LRV should be assessed in the same way as they are under controlled internal conditions. However, it is still considered good practice to adopt the recommended LRV differences, as shown in Table 5, in the external environment.

The exterior and interior environment, particularly markings, should be well maintained.

### **B.7.2 Determination of visual contrast**

#### **B.7.2.1 Difference in LRV values**

The method for determination of visual contrast recommended in this International Standard is based on the difference in LRV of the two adjacent surfaces or of a component and its background ( $LRV_1 - LRV_2$ ). The recommended point difference between two surfaces in LRV values is described in 35.1 and Table 5. For appropriate visual contrast one of the two surfaces should have a light reflectance value of minimum 40 points for large area surfaces, 70 points for potential hazards and text information to make sure that the LRV of the lighter surface will be perceptible under the light conditions defined in Clause 33. The LRV of a surface is

defined in 3.41 and further defined as CIE Y (see CIE, 2004, "Colorimetry"). The Luminance ( $L$ ) of a surface or the light emitted from a surface is measured in candelas per 1 m<sup>2</sup> and can be determined by:

$$L = [(E \times x_{LRV})/\pi]$$

where

$E$  is the illuminance of the surface or the number of lumens per 1 m<sup>2</sup> falling on the surface;

$x_{LRV}$  is the light reflectance value.

### B.7.2.2 Determination of LRV

LRV should be determined under stable and controlled lighting conditions. The measurement of LRV can be classified into two major methods according to the measurement instruments that are used. Method 1 is the Contact method and Method 2 the Noncontact method. The measurement instruments shall be calibrated to the spectral sensitivity of the human eye, corrected to align with the CIE photopic curve,  $V(\lambda)$ .

Method 1 uses specialist sphere type spectrophotometer equipment, which has a 10° visual field and gives the most accurate and repeatable measurements for flat surfaces. This equipment can accurately measure the LRV of matte opaque surfaces. Although the equipment can measure the LRV of specular reflecting surfaces, e.g. metallic and glossy surfaces, there are concerns regarding the accuracy and repeatability of the measurements. There are similar concerns about accuracy and repeatability of measurements of carpets. A range of internationally standardized light sources is built into the spectrophotometer allowing the influence of a wide range of light sources on the LRV of surfaces to be determined. For this International Standard the light source should be the D65 type. The method is suitable to determine the LRVs of products and surfaces for which visual contrast is an issue. The number of measurement points on each surface will be selected in order to provide a representative series of measurements. At each measurement point, after the first measurement, the instrument will be turned 90° three times and measurements taken after each 90° turn. These multiple measurements are averaged to obtain a typical value for the surface.

Method 2 uses a handheld luminance meter and a white, high reflectance standard surface. Since the reflectance of the white standard surface has a known LRV or CIE Y value, it is possible to calculate the LRV of the surface of interest by measuring the luminance of both surfaces under the same lighting conditions. In practice the luminance meter is arranged to view part of the surface without producing shadows and the luminance is measured. Immediately after this measurement the white standard surface is placed in position on the same part of the surface and the luminance measured. Luminance is the amount of light emitted from a surface. This is commonly termed the brightness of the surface. The LRV of the surface of interest (LRV<sub>i</sub>) can be determined from:

$$x_{LRV,i} = (L_i/L_s) \times x_{LRV,s}$$

where

$L_i$  is luminance of the surface of interest (cd/m<sup>2</sup>);

$L_s$  is luminance of the white standard surface (cd/m<sup>2</sup>);

$x_{LRV,i}$  is light reflectance value of the surface of interest (CIE Y);

$x_{LRV,s}$  is light reflectance value of the white standard surface (CIE Y).

Multiple measurements are averaged to obtain a typical value for the surface.

The LRVs measured in accordance with Method 2 are dependent on the ambient lighting, which should be quoted in relation to any measurements taken. This method is not able to accurately assess the influence of glossy or metallic surfaces on the measured LRV, nor is it able to measure the LRV of curved surfaces. Whilst the LRVs determined by this method are useful, they are not as accurate as those obtained by using Method 1.

An alternative method of approximating the LRV of a surface is by reference to colour swatches or panels of colour samples. The LRV of the various colours can be obtained from the manufacturer of the colour swatches or samples. In some cases, the colour notation on the sample includes the LRV. By placing the colour swatch against the coloured surface of interest, a reasonable match can be identified. The LRV of the nearest colour match from the swatch can then be assumed to be the LRV of the surface of interest. The LRVs approximated in this way are also dependent on the ambient lighting, which needs to be quoted in relation to any approximation. This approximate measurement method is not able to accurately assess the influence of gloss on LRV. This very approximate method can be used for the initial selection of colours for design purposes and for preliminary site assessments.

To determine the difference in LRV of two surfaces, their LRV should be known. Manufacturers can provide LRVs of colours and finishes as determined by test methods described in this section.

### B.7.2.3 Other methods for determination of visual contrast

To determine visual contrast, different algorithms are used throughout the world. Tables B.1 and B.2 show four of these methods and tabulate the differences in LRV which result in their application to a range of typical required minimum LRV differences as shown in Table 5. The first algorithm is the simple difference between two LRVs, or  $(LRV_1 - LRV_2)$ . The three other algorithms are very similar, in that each of the algorithms involves two similar variables and the resultant difference is a dimensionless ratio. However, if the same LRVs are input to the three algorithms then the three algorithms produce different values for visual contrast, and this is shown in Table B.1. This is because the three algorithms involve a fraction with the LRV difference as the numerator and different denominators. In particular the visual contrast determined by the three algorithms shows significant differences with the LRV difference method for relatively dark surfaces. This is clearly shown in Table B.1 where the shadowed background shows LRV differences greater than determined by the simple difference between two LRVs. This in turn means that where the three algorithms are used to meet the LRV differences recommended in 35.1 and Table B.1, it is essential that in addition to the recommended luminance contrast for each algorithm according to Table B.2, the minimum reflectance of the lighter surface of 40 points for large area surfaces and elements for orientation and 70 points for hazards is achieved.

**Table B.1 — Differences between the simple method of difference in LRV and the three algorithms most commonly used throughout the world**

NOTE The shadowed background shows LRV differences greater than determined by the simple difference between two LRVs.

Visual task	LRV1	LRV2	ISO 21542 ( $LRV_1 - LRV_2$ )	Michelson	Weber	Sapolski
				$\frac{LRV_1 - LRV_2}{LRV_1 + LRV_2} \times 100$	$\frac{LRV_1 - LRV_2}{LRV_1} \times 100$	$\frac{LRV_1 - LRV_2}{0.05 \cdot (LRV_1 + LRV_2)} \times 100$
Large area surfaces (i.e. walls, floors, doors, ceiling), elements and components to facilitate orientation (i.e. handrails, switches and controls, tactile walking surface indicators)	40	10	30	63	75	50
	50	20	30	43	60	39
	60	30	30	33	50	33
	70	40	30	27	43	28
	80	50	30	23	38	24
Potential hazards (i.e. steps, glass surfaces) and text information	70	10	60	75	86	71
	80	20	60	60	75	60
	90	30	60	50	67	52

LRV1 is the LRV of surface 1 and LRV2 is the LRV of surface 2. The relationship between luminance and LRV is shown in B.7.2.1.

When instead of the difference in LRV one of the other algorithms is used for determination of contrast, the requirements in 35.1 and Table B.1 of this International Standard should be converted according to Table B.2 to achieve similar visual contrast.

**Table B.2 — Recommended visual contrast according to 35.1 and Table B.1 converted for the three algorithms most commonly used throughout the world**

Visual task	Minimum reflectance of the lighter surface	Michelson $C = \frac{(L_1 - L_2)}{(L_1 + L_2)} \times 100\%$	Weber $C = \frac{(L_1 - L_2)}{L_1} \times 100\%$	Sapolski $C = \frac{(Y_1 - Y_2)}{(Y_1 + Y_2 + 25)} \times 125\%$
Large area surfaces, elements and components to facilitate orientation	$Y_1 \geq 50$	30 %	46 %	30 %
Potential hazards and text information	$Y_1 \geq 70$	60 %	75 %	60 %

In Table B.2,  $L$  is the measured luminance of a surface and  $Y$  is the luminance reflectance. Where  $L$  appears in a formula,  $Y$  can be used instead.

### B.7.3 Relevant design factors

To emphasise features and assist in navigation, certain factors should be considered in any design:

- to distinguish the boundaries of larger surfaces such as floors, walls, doors and ceilings, appropriate differences in LRV should be used. The LRV of a wall colour should be different to that used on a ceiling and floor;
- to provide an accurate impression of the size of a space, the LRV of deep skirting boards should be the same as that of the wall (less important for a shallow skirting up to 100 mm or 125 mm deep);
- reflections and glare from shiny surfaces confuse people with visual impairments and the use of these finishes on larger areas should be avoided. Glare may additionally affect the ability of people who have a hearing impairment to communicate using lip reading;
- adequate visual contrast should be used to identify potential hazards;
- it is thought that LRV differences are less important between two large areas, e.g. between wall and floor, than between a small object on a larger background surface, e.g. a light switch on a wall.

To highlight the presence of a door, different measures are recommended:

- The architrave around a door should have visual contrast to the surrounding wall, in order to identify the presence of the door even when the door is open.
- Preferably, the door and the architrave should contrast with the surrounding wall. If the door and the wall have similar LRV and only the LRV of the architrave provides the contrast, it will still be possible to identify the presence of a feature, but it may take longer to identify it as a door opening.
- In the case of door opening furniture, the ease with which blind and partially sighted people are able to distinguish them against a background is influenced by their 3-D form (giving light and shade) and the shiny nature of the finish, whether metallic or non-metallic. For such products, it is considered that a difference in LRV between the product and its background of at least 15 points is acceptable.

The above list highlights only a few areas for consideration. Additionally, there are many other factors, which affect selection and use of colours in environments.

NOTE More information about colour contrast and perception has been published in different countries (i.e. Australia, Germany, Japan, USA, UK<sup>[77]</sup>).

## B.8 Indoor air quality (IAQ)

Poor indoor air quality (IAQ), an important factor in relation to building related ill health (also known as "sick building syndrome"), can cause serious health impairments and severely restrict a person's participation in everyday activities, e.g. work.

Symptoms and signs may include:

- irritation of eyes, nose and throat;
- respiratory infections and cough;
- voice hoarseness and wheezing;
- asthma;
- dry mucous membrane and skin;
- erythema (reddening or inflammation of the skin);
- lethargy;
- mental fatigue and poor concentration;
- headache;
- stress;
- hypersensitivity reactions, i.e. allergies;
- nausea and dizziness;
- cancer.

These symptoms and signs are present in the population at large, but are distinguished by being more prevalent in some building users, as a group, when compared with others. The symptoms and signs may disappear, or may be reduced in intensity, when an affected person leaves the building. It is not necessary for everyone in a building to be affected before building related ill health is suspected.

ISO 16814 covers methods of expressing IAQ and incorporating the goal of achieving good IAQ into the building design process. It also covers ventilation effectiveness, harmful emissions from building materials, air cleaning devices, and heating, ventilation and air conditioning equipment.

The indoor pollutants considered in ISO 16814 include human bio-effluents, which have often been the principal consideration in air quality and ventilation design, but also the groups and sources of pollutants which can reasonably be anticipated to occur in the building during its long life cycle.

These pollutants, depending on the sources present, may include:

- volatile organic compounds (VOCs) and other organics, such as formaldehyde;
- environmental tobacco smoke (ETS);
- natural radon, consisting of a number of different isotopes, an invisible radioactive gas found in the soils under buildings, water supplies to buildings and in the air;

- other inorganic gases, such as carbon monoxide (CO), the oxides of nitrogen (NO<sub>x</sub>), and low-level ozone (smog) which is formed when NO<sub>x</sub> and VOCs react in the presence of sunlight;
- viable particles, including viruses, bacteria and fungal spores;
- non-viable biological pollutants, such as particles of mites or fungi and their metabolic products;
- non-viable particles, such as dusts and fibres.

The following two performance indicators of good IAQ, developed with the aim of protecting human health, are recommended:

- radon activity (incl. Rn-222, Rn-220, RnD) in a building should, on average, fall within the range of 10 Bq/m<sup>3</sup> to 40 Bq/m<sup>3</sup>, but should at no time exceed 60 Bq/m<sup>3</sup>;
- carbon dioxide (CO<sub>2</sub>) concentrations in a building should not significantly exceed average external levels – typically within the range of 300 ppm to 500 ppm – and should at no time exceed 800 ppm.

## B.9 Allergy related materials

Buildings and their installations shall be designed so that necessary conditions for less allergy related materials in rooms which are in frequent use by human beings are created and determined on the basis of the intended use of the room. People with allergies or certain sensitiveness are more dependent on good air quality with less pollutants or unpleasant smells and allergy related materials than other persons.

The use of materials with high emission levels is to be avoided. Materials that do not emit large quantities of pollutants or emissions should be selected.

Typical materials to which the user may be allergic include nickel, chromium, cobalt and natural or synthetic rubber. Materials causing allergies should be avoided in buttons, controls, handles or handrails.

Avoid perfumed products and implement a "scent-free" policy including for example soap used on toilets and scent-free cleaning products or such additives in the climatic system. Devices that emit scents should be avoided.

## Annex C (informative)

### Circulation spaces at doorways

#### C.1 General

On every accessible path of travel, sufficient circulation spaces should be provided in both directions at doorways.

Basic guidance on the minimum horizontal manoeuvring space of an entrance doorway is given in 10.7. This annex provides alternative openings and constructions. Recommendations are given for swinging doors, as well as for sliding doors, and the way of approaching the door is considered.

According to 18.1.3, a manoeuvring space of not less than 600 mm shall be provided between the leading edge of the door and the wall that is perpendicular to the doorway). Other dimensions are considered in this annex, because it provides alternative solutions. Nevertheless, when stating the compliance with this International Standard, the requirements given in 18.1.3 should always be fulfilled.

#### C.2 Swinging doors

The clear circulation space at doorways with swinging doors is based on the unobstructed width of the doorway ( $D$ ). The clear circulation space should not be less than the dimensions specified in Figures C.1 to C.8 for the appropriate unobstructed width ( $D$ ).



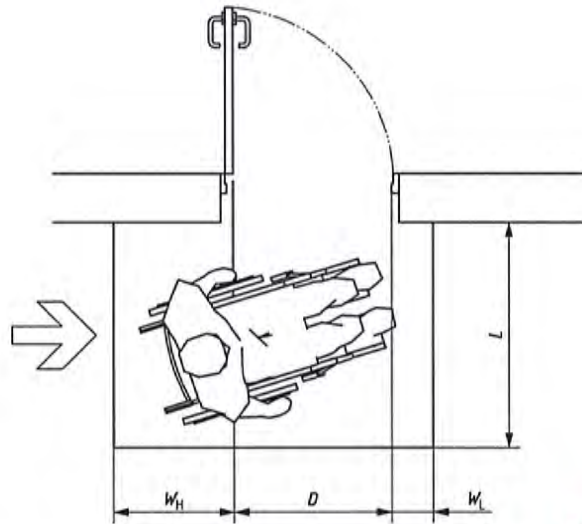

Dimension (mm)	Dimension (mm)	Dimension (mm)	Dimension (mm) <sup>a</sup>
$D$	$L$	$W_H$	$W_L$
800	1 260	610	340
850	1 220	560	340
900	1 185	510	340
950	1 160	460	340
1 000	1 140	410	340

<sup>a</sup> Informative only. See requirements given in 18.1.3.

Figure C.1 — Circulation spaces at doorways with swinging doors —  
Hinge-side approach: door opens away from user

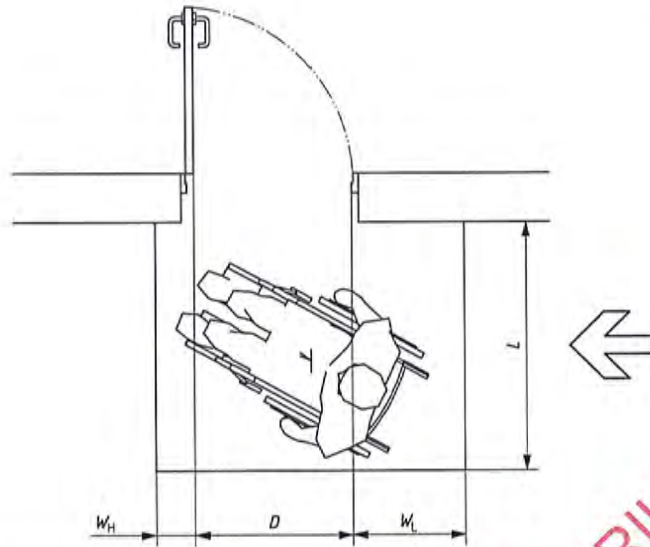

Dimension (mm)	Dimension (mm)	Dimension (mm)	Dimension (mm)
$D$	$L$	$W_H$	$W_L$
800	1 270	200	660
850	1 240	240	660
900	1 210	190	660
950	1 175	140	660
1 000	1 155	90	660

Figure C.2 — Circulation spaces at doorways with swinging doors —  
Latch-side approach: door opens away from user

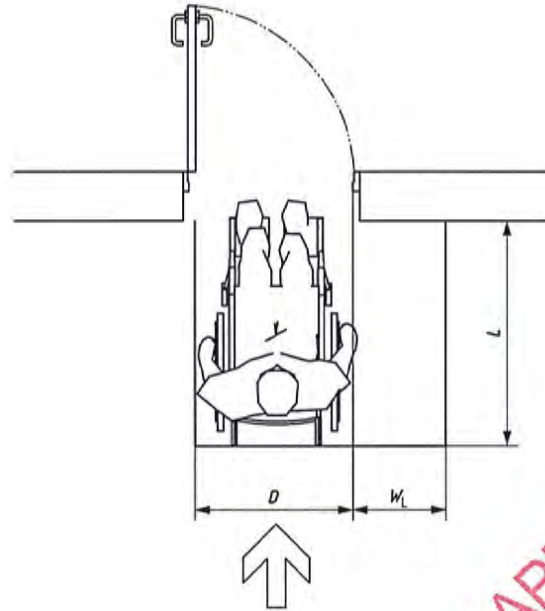

Dimension (mm)	Dimension (mm)	Dimension (mm)	Dimension (mm) <sup>a</sup>
$D$	$L$	$W_H$	$W_L$
800	1 450	0	510
850	1 450	0	510
900	1 450	0	510
950	1 450	0	510
1 000	1 450	0	510

<sup>a</sup> Informative only. See requirements given in 18.1.3.

Figure C.3 — Circulation spaces at doorways with swinging doors —  
Front approach: door opens away from user

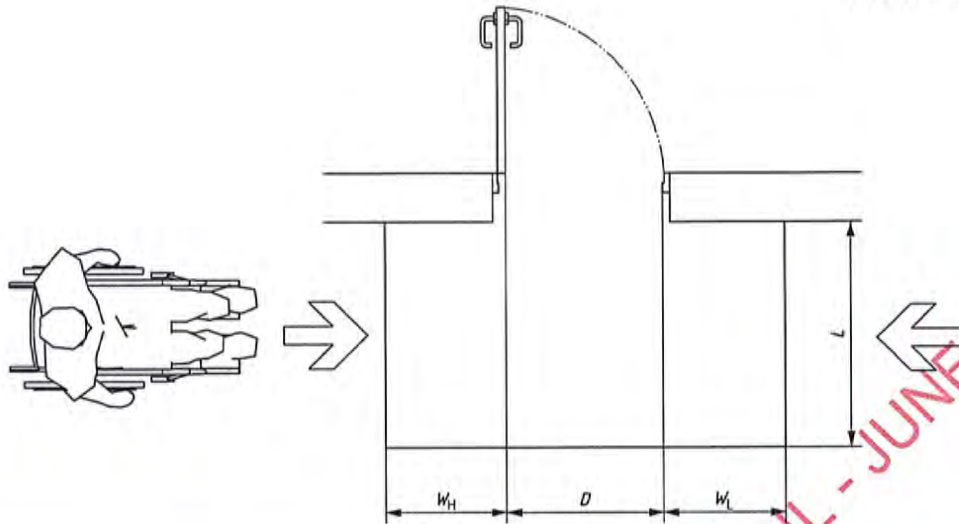

Dimension (mm)	Dimension (mm)	Dimension (mm)	Dimension (mm)
$D$	$L$	$W_H$	$W_L$
800	1 270	610	660
850	1 240	560	660
900	1 210	510	660
950	1 175	450	660
1 000	1 155	410	660

Figure C.4 — Circulation spaces at doorways with swinging doors —  
Either approach: door opens away from user

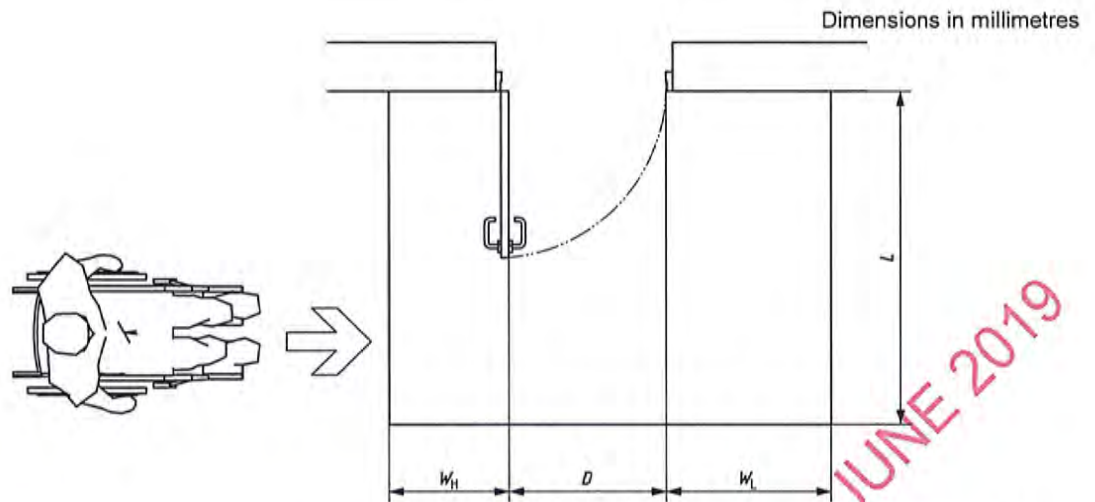

Dimension (mm)	Dimension (mm)	Dimension (mm)	Dimension (mm)
$D$	$L$	$W_H$	$W_L$
800	1 670	670	900
850	1 670	660	900
900	1 670	610	900
950	1 670	560	900
1 000	1 670	510	900

Figure C.5 — Circulation spaces at doorways with swinging doors —  
Hinge-side approach: door opens towards user

Dimensions in millimetres

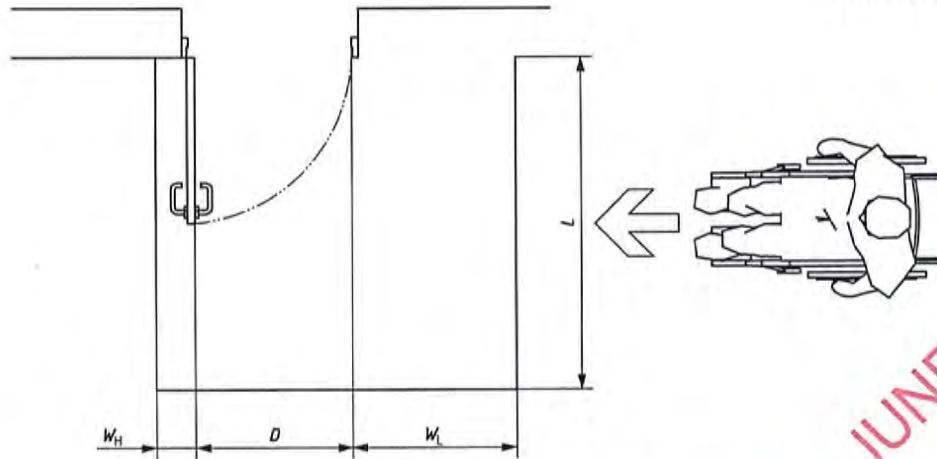

Dimension (mm)	Dimension (mm)	Dimension (mm)	Dimension (mm)
$D$	$L$	$W_H$	$W_L$
800	1 670	110	900
850	1 670	110	900
900	1 670	110	900
950	1 670	110	900
1 000	1 670	110	900

Figure C.6 — Circulation spaces at doorways with swinging doors —  
Latch-side approach: door opens towards user

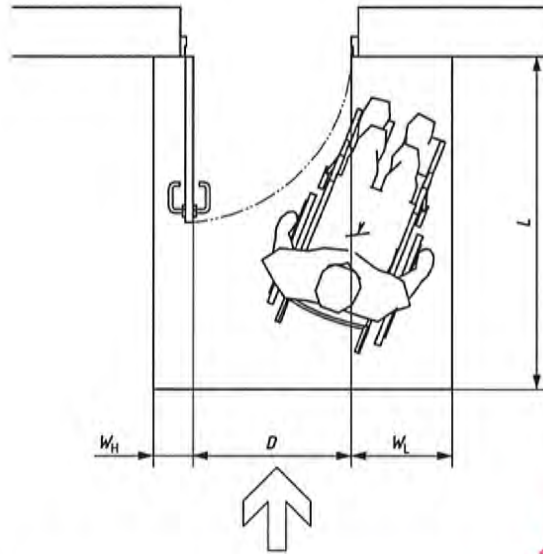

Dimension (mm)	Dimension (mm)	Dimension (mm)	Dimension (mm) <sup>a</sup>
$D$	$L$	$W_H$	$W_L$
800	1 450	110	530
850	1 450	110	530
900	1 450	110	530
950	1 450	110	530
1 000	1 450	110	530

<sup>a</sup> Informative only. See requirements given in 18.1.3.

Figure C.7 — Circulation spaces at doorways with swinging doors —  
Front approach: door opens towards user

Dimensions in millimetres

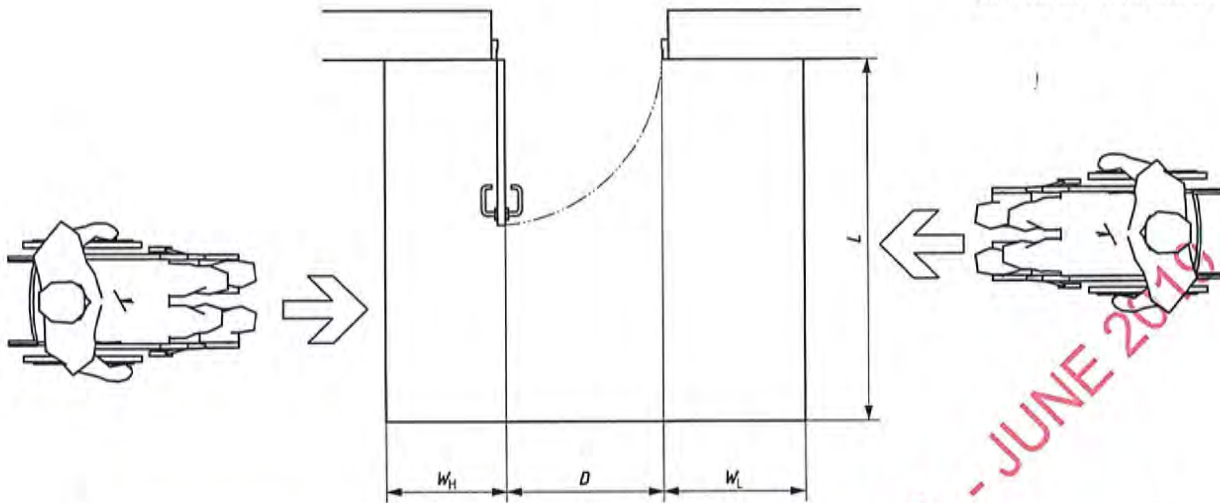

Dimension (mm)	Dimension (mm)	Dimension (mm)	Dimension (mm)
$D$	$L$	$W_H$	$W_L$
800	1 670	710	900
850	1 670	660	900
900	1 670	610	900
950	1 670	560	900
1 000	1 670	510	900

Figure C.8 — Circulation spaces at doorways with swinging doors —  
Either approach: door opens towards user



### C.3 Sliding doors

The clear circulation space at doorways with sliding doors is based on the unobstructed width of the doorway ( $D$ ). The clear circulation space should not be less than the dimensions specified in Figures C.9 to C.12 for the appropriate unobstructed width ( $D$ ).

Dimensions in millimetres

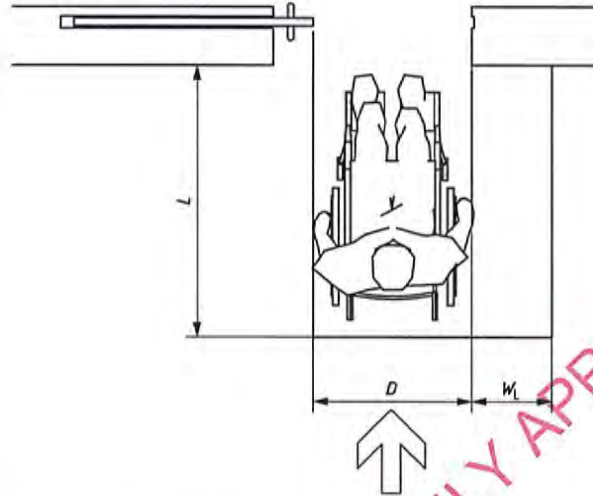

Dimension (mm)	Dimension (mm)	Dimension (mm)	Dimension (mm) <sup>a</sup>
$D$	$L$	$W_H$	$W_L$
800	1 450	0	530
850	1 450	0	530
900	1 450	0	530
950	1 450	0	530
1 000	1 450	0	530

<sup>a</sup> Informative only. See requirements given in 18.1.3.

Figure C.9 — Circulation spaces at doorways with sliding doors — Front approach

Dimensions in millimetres

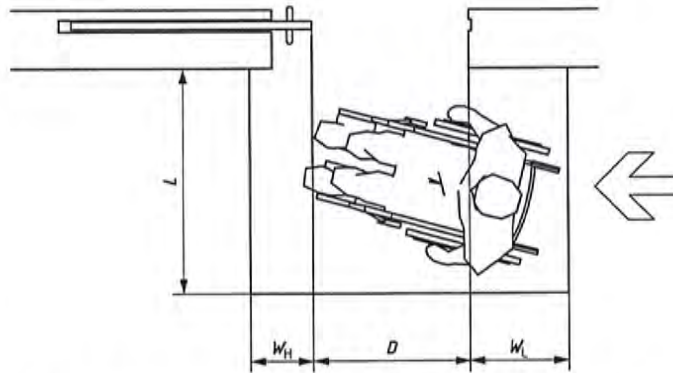

Dimension (mm)	Dimension (mm)	Dimension (mm)	Dimension (mm)
$D$	$L$	$W_H$	$W_L$
800	1 230	190	660
850	1 230	185	660
900	1 230	180	660
950	1 230	180	660
1 000	1 230	180	660

Figure C.10 — Circulation spaces at doorways with sliding doors — Latch-side approach

Dimensions in millimetres

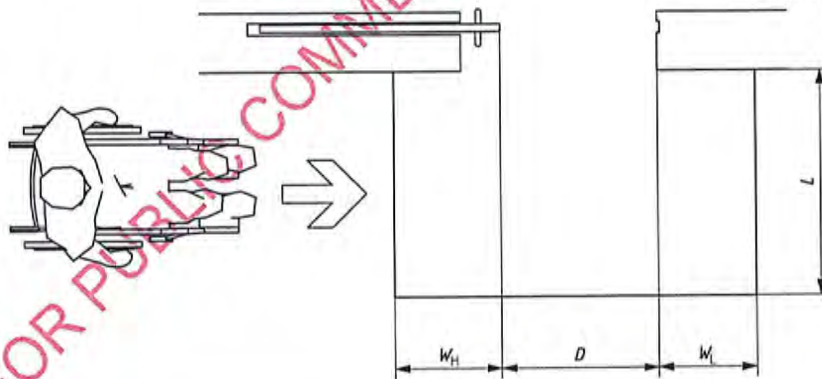

Dimension (mm)	Dimension (mm)	Dimension (mm)	Dimension (mm) <sup>a</sup>
$D$	$L$	$W_H$	$W_L$
800	1 280	710	395
850	1 280	660	395
900	1 280	610	395
950	1 280	560	395
1 000	1 280	510	395

<sup>a</sup> Informative only. See requirements given in 18.1.3.

Figure C.11 — Circulation spaces at doorways with sliding doors — Slide-side approach

Dimensions in millimetres

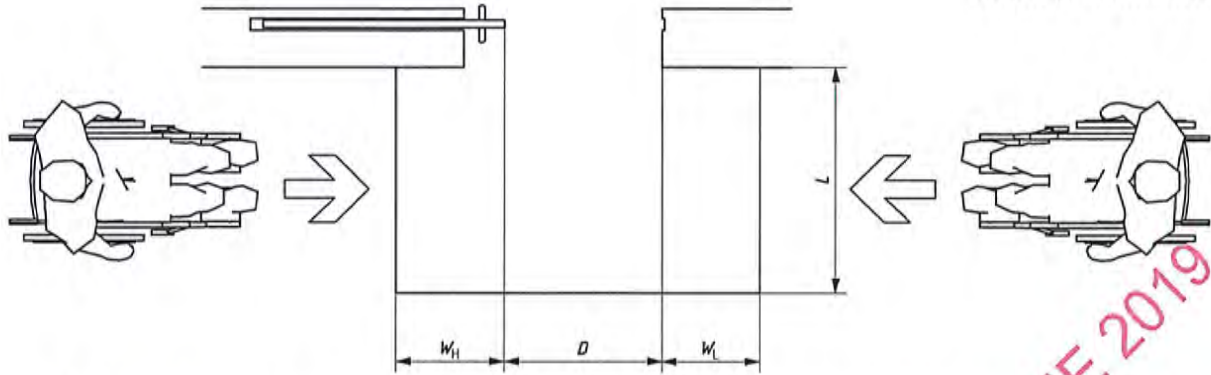

Dimension (mm)	Dimension (mm)	Dimension (mm)	Dimension (mm)
$D$	$L$	$W_H$	$W_L$
800	1 280	710	660
850	1 280	660	660
900	1 280	610	660
950	1 280	560	660
1 000	1 280	510	660

Figure C.12 — Circulation spaces at doorways with sliding doors — Either approach

FDBNS FOR PUBLIC COMMENTS ONLY APRIL - JUNE 2019

## Annex D (informative)

### Fire safety and assisted evacuation for all in buildings

#### D.1 Fire safety, protection and evacuation for all

##### D.1.1 Human behaviour in fire emergencies

The "real" people who use "real" buildings every day of every week, in all parts of the world, have widely differing ranges of human abilities and activity limitations. They are different from each other, and they react differently in a fire emergency.

All building users should be made aware of evacuation procedures.

Meaningful consultation with every person known to occupy or use a building, for the purposes of receiving his or her active co-operation and obtaining his or her informed consent (involving a personal representative, if required), is an essential component of adequate pre-planning and preparation for a fire emergency.

Warnings of any fire incident in a building should be communicated as soon as is practicable after the initiation of a fire incident and should continue for the full duration of the incident. Warnings should be informative, and be easily assimilated in a form (e.g. oral, written, Braille) and language understood by the people using the building.

##### D.1.2 Building design for accessibility and reliability

Accessibility design guidelines should be applied to the design of all fire evacuation routes, horizontal and vertical, inside the building and externally to a place of safety (see 3.48).

As some people with mobility impairments may potentially have to wait for assistance in a building which is on fire, the fire protection measures and fire management systems in an occupied building should be reliable. In other words, when assessing the ability of a design to achieve the stated objectives for all populations, the evaluation should consider the reliability of every element as well as its presence or absence and its effectiveness.

**NOTE** Ten percent of people using the building (occupants, visitors and other users) may have an impairment (visual or hearing, physical function, mental, cognitive or psychological, with some impairments not being identifiable, e.g. in the case of anosognosia).

Throughout the duration of a fire incident and for a specified period afterwards, the accessibility of available fire evacuation routes, inside the building and externally to a "place of safety", should be maintained. When assessing the ability of a design to achieve the stated objectives, the evaluation should consider the potential for loss of evacuation route availability or capacity as a result of other actions, including firefighter access, rescue, and fire fighting operations.

#### D.2 Assisted evacuation and rescue from buildings — Rescue techniques

Firefighters have two principal functions:

- a) rescuing people who are trapped in buildings, or who for some reason cannot independently evacuate a building which is on fire, and
- b) fighting fires.

People with disabilities are participating more and more, and in ever increasing numbers, in mainstream society. It is recommended that firefighters receive training in how best to rescue a person with a disability from a building, using procedures and equipment which should not cause further harm or injury to that person.

NOTE The 2002 FEMA (USA) Orientation Manual<sup>[72]</sup> shows and describes many assisted evacuation and rescue techniques for people with widely differing ranges of activity limitation.

Manual handling of wheelchairs occupied by their users in a fire evacuation staircase, even with adequate training for everyone directly and indirectly involved, is hazardous for the person in the wheelchair and those people giving assistance.

Local fire authorities should ensure that they possess the necessary equipment to rescue people with a wide range of impairments, and that specialized rescue equipment is regularly serviced and maintained. Every fire authority should have an 'accessible' and 'reliable' emergency call system which is available at all times to the public.

It is essential that every firefighter be fully aware of this important public safety issue, and be regularly trained in the necessary rescue procedures involving people with a wide range of impairments.

### D.3 Management of fire evacuation lifts in buildings

A lift (elevator) to be used for the fire evacuation of people with activity limitations and/or with impaired senses should be operated under the strict direction and control of building management.

It is essential that the lift (elevator) be able to continue to operate effectively and safely for a specified time during a fire, and that it is taken only to those floors where it is necessary for building personnel to evacuate a person by lift (elevator).

NOTE ISO/TC 178 is currently working on the future ISO/TR 25742<sup>2)</sup>, "*Lifts (elevators) — Study of the methods used for fire testing lift landing doors*".

For such a management system to work properly, a suitable number of trained and experienced "fire wardens" should be designated on each floor of a building. They should be competent to carry out their duties in a fire emergency, and should be available at all times when the building is occupied.

A lift (elevator) used for fire evacuation should be fitted with an accessible and reliable communications system, which facilitates direct contact with a person in the main fire and security centre for the building.

If an evacuation lift fails to arrive at a floor landing, or access to it on any floor is obstructed by fire and/or smoke, an evacuation staircase should be used. Should the lift (elevator) remain safe to use, it may only be necessary to descend to the floor below the fire using an evacuation staircase, and from there continue the descent by lift (elevator).

### D.4 Evacuation skills and self protection from fire in buildings

A "skill" is the ability of a person, resulting from adequate training and regular practice, to carry out complex, well-organized patterns of behaviour efficiently and adaptively, in order to achieve some end or goal.

Building users should be skilled for evacuation to a "place of safety", which is at a safe distance from the building (see 3.48). Non-emergency/test evacuations should be carried out sufficiently often to equip building users with this skill.

Fire protection measures and human management systems are never 100 % reliable. It is necessary, therefore, especially for people with activity limitations and/or impaired senses, to be familiar with necessary guidelines for self-protection in the event of a fire emergency.

---

2) Under preparation.

## Annex E (informative)

### Management and maintenance issues

#### E.1 General

The following management and maintenance issues, based on BS 8300, are important factors in ensuring that a building is easily accessed and used by disabled people.

#### E.2 External issues

- a) Keeping external routes, including steps and ramps, clean, unobstructed and free of surface water, snow, ice, dead leaves, lichen, debris, etc.;
- b) in car parking areas: ensuring that designated spaces are not being used by non-disabled motorists;
- c) where possible, allocating specific designated parking spaces to individual employees, marked by name or number;
- d) checking side-hung doors accompanying revolving doors to ensure they are not kept locked;
- e) making available auxiliary aids such as portable ramps, and removing them when not in use.

#### E.3 Internal issues

- a) Ensuring that wheelchair spaces are available in seating areas;
- b) ensuring that staff understand the management issues relating to disabled people, including emergency procedures;
- c) ensuring that storage, planters, bins, etc., do not obstruct circulation space, WCs or lift call buttons;
- d) ensuring that cleaning and polishing does not produce a slippery surface;
- e) ensuring that trip hazards, such as at junctions between floor surfaces, are removed;
- f) ensuring access between moveable tables in refreshment areas;
- g) ensuring that in sanitary facilities, written instructions on the use of equipment is displayed beside each item;
- h) ensuring in sanitary facilities, that information is available on the type of sling connector and the types of sling that are compatible with their installed hoist and track;
- i) ensuring that a procedure is set up to respond to alarm calls from sanitary accommodation;
- j) ensuring that waterproof mattress covers can be made available for use in accessible bedrooms;
- k) ensuring that, where floor sockets are provided (e.g. in meeting rooms), access to sockets is also available at desk level;

- l) ensuring that any temporary barriers that are used to channel customers to reception or serving points, and whose configuration needs to be changed frequently, have a semi-rigid top barrier (e.g. a spring-loaded band) which contrasts visually with the background against which it is seen;
- m) ensuring that assistance is made available to carry trays where needed in refreshment areas;
- n) ensuring that suitable arrangements are made for assistance dogs while their owners are using leisure facilities.

#### **E.4 Maintenance issues**

- a) Maintaining doors, door closers and building hardware, including checking that the opening forces of self-closing doors are within acceptable limits;
- b) maintaining access control systems;
- c) checking floor surfaces, matting, surface-mounted carpets, etc., re-fixing to the floor where necessary, and replacing where damaged or worn (particularly at entrances to buildings);
- d) maintaining hearing enhancement systems;
- e) maintaining sanitary fittings, including checking that toilet seats are securely fixed, cleaning tap nozzles to ensure correct water flow, emptying and cleaning bins, and keeping equipment clean;
- f) ensuring that adjustable shower heads are lowered to be ready for the next user;
- g) ensuring that emergency assistance pull cords are kept fully extended and in working order at all times;
- h) checking the mountings of all grab rails, and the mechanism of drop-down rails, re-fixing or replacing where necessary;
- i) servicing of all types of lifts and hoists;
- j) ensuring that facilities, such as lifts, hoists, etc., are in working order between servicing schedules, and providing alternative arrangements in case of facilities being out of order;
- k) maintaining ventilation and heating equipment;
- l) replacing defunct light bulbs and flickering fluorescent tubes quickly;
- m) keeping windows, lamps and blinds clean to maximize lighting.

#### **E.5 Communication issues**

- a) Providing information on strobe lighting prior to entry;
- b) removing and/or changing signage as necessary, e.g. when departments relocate;
- c) providing accurate information on facilities prior to arrival;
- d) providing audio description services;
- e) providing all relevant literature, and reviewing/revising it when necessary;
- f) ensuring that a permanently manned position is available for the emergency lift telephone communications;

- g) updating maps of buildings following changes;
- h) replacing signs correctly after decoration.

## E.6 Policy issues

- a) Allocating and reviewing parking spaces;
- b) changing signs when departments move;
- c) reviewing the number of disabled people attending and needing facilities;
- d) establishing and running user groups;
- e) reviewing the number of instruments supporting infra red systems;
- f) adopting a signage policy;
- g) having the loop position always manned in branches;
- h) providing portable ramps;
- i) arranging audits of journeys made by visitors;
- j) instructing accessibility audits;
- k) ensuring that services are provided when facilities such as lifts break down;
- l) ensuring that responsibilities are defined within the organization;
- m) ensuring that accessibility improvements are picked up whenever possible during maintenance and refurbishment work;
- n) reviewing and improving evacuation procedures;
- o) training of staff;
- p) reviewing all policies, procedures and practices;
- q) reviewing the provision of auxiliary aids;
- r) considering the impact of background noise (e.g. music, equipment, ventilation) on people with a range of sensory conditions (hearing, vision, autism). This is especially important in areas where voice communication is necessary, such as reception, meeting and learning spaces.



## Bibliography

- [1] ISO 128-30, *Technical drawings — General principles of presentation — Part 30: Basic conventions for views*
- [2] ISO 128-34, *Technical drawings — General principles of presentation — Part 34: Views on mechanical engineering drawings*
- [3] ISO 128-40, *Technical drawings — General principles of presentation — Part 40: Basic conventions for cuts and sections*
- [4] ISO 128-44, *Technical drawings — General principles of presentation — Part 44: Sections on mechanical engineering drawings*
- [5] ISO 690, *Information and documentation — Guidelines for bibliographic references and citations to information resources*
- [6] ISO 1804, *Doors — Terminology*
- [7] ISO 3864-1, *Graphical symbols — Safety colours and safety signs — Part 1: Design principles for safety signs and safety markings*
- [8] ISO 6707-1, *Building and civil engineering — Vocabulary — Part 1: General terms*
- [9] ISO 7000, *Graphic symbols for use on equipment — Index and synopsis*
- [10] ISO 7001, *Graphical symbols — Public information symbols*
- [11] ISO 7010, *Graphical symbols — Safety colours and safety signs — Registered safety signs*
- [12] ISO 7730, *Ergonomics of the thermal environment — Analytical determination and interpretation of thermal comfort using calculation of the PMV and PPD indices and local thermal comfort criteria*
- [13] ISO 9999, *Assistive products for persons with disability — Classification and terminology*
- [14] ISO/IEC TR 10000-1, *Information technology — Framework and taxonomy of International Standardized Profiles — Part 1: General principles and documentation framework*
- [15] ISO 10241-1, *Terminological entries in standards — Part 1: General requirements and examples of presentation*
- [16] ISO 10241-2<sup>3)</sup>, *Terminological entries in standards — Part 2: Adoption of standardized terminological entries*
- [17] ISO 13943, *Fire safety — Vocabulary*
- [18] ISO 16069, *Graphical symbols — Safety signs — Safety way guidance systems (SWGS)*
- [19] ISO/TR 16738, *Fire-safety engineering — Technical information on methods for evaluating behaviour and movement of people*

---

3) Under preparation.

- [20] ISO 16813, *Building environment design — Indoor environment — General principles*
- [21] ISO 16814, *Building environment design — Indoor air quality — Methods of expressing the quality of indoor air for human occupancy*
- [22] ISO/TR 22411, *Ergonomic data and guidelines for the application of ISO/IEC Guide 71 to products and services to address the needs of older persons and persons with disabilities*
- [23] ISO/TR 25742<sup>3)</sup>, *Lifts (elevators) — Study of the methods used for fire testing lift landing doors*
- [24] ISO/TR 25743, *Lifts (elevators) — Study of the use of lifts for evacuation during an emergency*
- [25] ISO 28564-1, *Public information guidance systems — Part 1: Design principles and element requirements for location plans, maps and diagrams*
- [26] ISO 80000-1, *Quantities and units — Part 1: General*
- [27] IEC 60027 (all parts), *Letter symbols to be used in electrical technology*
- [28] IEC 60118-4, *Electroacoustics — Hearing aids — Part 4: Induction loop systems for hearing aid purposes — Magnetic field strength*
- [29] EN 81-40, *Safety rules for the construction and installation of lifts — Special lifts for the transport of persons and goods — Part 40: Stairlifts and inclined lifting platforms intended for persons with impaired mobility*
- [30] EN 81-41, *Safety rules for the construction and installation of lifts — Special lifts for the transport of persons and goods — Part 41: Vertical lifting platforms intended for use by persons with impaired mobility*
- [31] EN 81-70, *Safety rules for the construction and installation of lifts — Particular applications for passenger and good passenger lifts — Part 70: Accessibility to lifts for persons including persons with disability*
- [32] EN 115-1, *Safety of escalators and moving walks — Part 1: Construction and installation*
- [33] EN 1125:2008, *Building hardware — Panic exit devices operated by a horizontal bar, for use on escape routes — Requirements and test methods*
- [34] EN 1865, *Patient handling equipment used in road ambulances*
- [35] EN 12217, *Doors — Operating forces — Requirements and classification*
- [36] CEN/TR 15894:2009, *Building hardware — Door fittings for use by children, elderly and disabled people in domestic and public buildings — A guide for specifiers*
- [37] CEN/TS 81-82, *Safety rules for the construction and installation of lifts — Existing lifts — Part 82: Improvement of the accessibility of existing lifts for persons including persons with disability*
- [38] AS 1428.1, Draft 04019, *Design for access and mobility — General requirements for access — New building work*
- [39] AS 1428.4, *Design for access and mobility — Tactile indicators*
- [40] AS 1428.5, Draft 07014, *Design for access and mobility — Communication for people who are deaf or hearing impaired*
- [41] BS 5395-1, *Code of practice for the design of stairs with straight flights and winders*

- [42] BS 6180, *Barriers in and about buildings — Code of practice*
- [43] BS 8300, *Design of buildings and their approaches to meet the needs of disabled people — Code of practice*
- [44] BS 8493, *Light reflectance value (LRV) of a surface — Method of test*
- [45] BS 9999, *Code of practice for fire safety in the design, management and use of buildings*
- [46] DIN 18024-1, *Barrier-free built environment — Part 1: Streets, squares, paths, public transport, recreation areas and playgrounds — Design principles*
- [47] DIN 18040-1, *Construction of accessible buildings — Design principles — Part 1: Publicly accessible buildings*
- [48] DIN 18040-2, *Construction of accessible buildings — Design principles — Part 2: Dwellings*
- [49] DIN 18041, *Acoustic quality in small to medium-sized rooms*
- [50] GUIA UNIT 200, *Accesibilidad de las personas el entorno edificado — Niveles de accesibilidad recomendados*
- [51] NBR 9050, *Acessibilidade a edificações, mobiliário, espaços e equipamentos urbanos*
- [52] ÖNORM B 1600, *Building without barriers — Design principles*
- [53] ÖNORM B 1601, *Special buildings for handicapped and old persons — Design principles*
- [54] ÖNORM B 1602, *Barrier-free buildings for teaching and training and possible accompanying facilities (together with ÖNORM B 1600)*
- [55] ÖNORM B 1603, *Barrier-free buildings for tourism — Design principles (together with ÖNORM B 1600)*
- [56] ÖNORM B 1610, *Barrier-free buildings and installations — Requirements for evaluation of accessibility*
- [57] SN 521 500, *Obstacle free buildings*
- [58] UNE 41500:2001 IN, *Accesibilidad en la edificación y el urbanismo. Criterios generales de diseño (Accessibility in building and urbanism. General criteria of design)*
- [59] UNE 41501, *Símbolo de accesibilidad para la movilidad. Reglas y grados de uso (Symbol of accessibility for mobility. Rules and grades of use)*
- [60] UNE 41510, *Accesibilidad en el urbanismo (Accessibility in urbanism)*
- [61] UNE 41512, *Accesibilidad en las playas y en su entorno (Accessibility in beaches and in their environment)*
- [62] UNE 41513, *Itinerarios urbanos accesibles en casos de obras en la calle (Accessible urban itineraries in cases of urban works)*
- [63] UNE 41520, *Accesibilidad en la edificación. Espacios de comunicación horizontal (Accessibility in building. Horizontal communication elements)*
- [64] UNE 41522, *Accesibilidad en la edificación. Accesos a los edificios (Accessibility in building. Accesses to the buildings)*

- [65] UNE 41523, *Accesibilidad en la edificación. Espacios higiénico-sanitarios (Accessibility in building. Sanitary spaces)*
- [66] UNE 41524, *Accesibilidad en la edificación. Reglas generales de diseño de los espacios y elementos que forman el edificio. Relación, dotación y uso (Accessibility in building. General design rules for the spaces and elements in buildings. Links, equipment and use)*
- [67] UNIT 200, *Accesibilidad de las personas al medio físico. Criterios y requisitos generales de diseño para un entorno edificado accesible*
- [68] UNIT 906, *Accesibilidad de las personas al medio físico — Símbolo gráfico — Características generales (COPANT 1614)*
- [69] UNIT NM 313, *Ascensores de pasajeros — Seguridad para la construcción e instalación — Requisitos particulares para la accesibilidad de las personas, incluyendo las personas con discapacidad (COPANT 1629)*
- [70] EUROPEAN UNION, Council Decision concerning the conclusion, by the European Community, of the United Nations Convention on the Rights of Persons with Disabilities, OJ L 23, 27.1.2010
- [71] EUROPEAN UNION, Resolution of the Council of the European Union and the representatives of the Governments of the Member States, meeting within the Council of 17 March 2008 on the situation of persons with disabilities in the European Union, OJ C 75, 26.3.2008
- [72] FEDERAL EMERGENCY MANAGEMENT AGENCY (FEMA), UNITED STATES FIRE ADMINISTRATION, Orientation Manual for First Responders on the Evacuation of People with Disabilities, FA-235, August 2002
- [73] UN WORLD HEALTH ORGANIZATION, International Classification of Functioning, Disability and Health (ICF)
- [74] UN WORLD HEALTH ORGANIZATION, International Classification of Impairment, Disability and Handicap (ICIH-2)
- [75] UN WORLD HEALTH ORGANIZATION, Older persons in emergencies, August 2006
- [76] BRIGHT, K., COOK, G., "Project Rainbow. A research project to provide colour and contrast design guidance for internal built environments", The Chartered Institute of Building Occasional Paper No. 57, The Chartered Institute of Building, 1999, ISBN 1 85380 084 8
- [77] BRIGHT, K and COOK, G, "The Colour, Light and Contrast Manual", Wiley- Blackwell 2010, ISBN 978-1-4051-9504-1
- [78] *Guidance on the Implications of the ISO Global Relevance Policy for CEN Standardization*, 2005



FDBNS FOR PUBLIC COMMENTS ONLY APRIL - JUNE 2019

---

**ICS 91.060.01**

Price based on 152 pages

© ISO 2011 – All rights reserved